

S4

MANUAL



Quench USA Inc.
630 Allendale Road, Ste 200
King of Prussia, PA 19406
(800) 288-1891 www.wellsysdealers.com

S4 MANUAL

Congratulations on your choice of the **Wellsys S4 Water Treatment System**. The **S4** model dispenses hot, cold, ambient, and sparkling water. The **Wellsys S4 Water Treatment System** provides exceptional quality and great tasting water with every use.

INTRODUCTION

Carefully read and follow all instructions to ensure proper and efficient operation of your **Wellsys Water Treatment System**. Contact your **Authorized Wellsys Dealer** if you have any questions.

Wellsys and **Authorized Wellsys Dealers** employ trained service personnel who are experienced in the installation, function, and repair of this equipment. This publication is written for use by these qualified individuals. **Wellsys** encourages users to learn about products, however, we believe that product knowledge and service is best obtained by consulting your **Authorized Wellsys Dealer**.

Wellsys Water Treatment Systems should be combined with selected water treatment components to create a system specifically tailored for each application by trained and qualified personnel.

Products manufactured and marketed by **Wellsys** and its affiliates are protected by patents issued or pending in the United States and other countries.

Wellsys reserves the right to change the specifications referred to in this literature at any time, without prior notice. Changes or modifications not expressly approved by **Wellsys** could void the warranty and user's authority to operate the equipment.

TABLE OF CONTENTS

USER GUIDE

- Safety Alert Symbols 4
- Safety Precautions 4
- Features and Benefits 6
- Certifications 7
- Model Designations and General Specifications 8
- Shipping Specifications 9
- Receiving Your Equipment 10
- Display and Control Panel 11
- Operating Instructions 12
- Warranty 13

SERVICE GUIDE

- Service Requirements 14
- S4 Parts List..... 15
- Flow Diagram 21
- PCB Diagram..... 22
- Electrical Diagram 23

INSTALLATION GUIDE

- Pre-Installation Procedures 25
- Notes on Installation 26
- Installing the CO2 Tank 27
- Installation 28
- Sanitizing 31
- Final Inspection 33
- Base Hole Modification 34
- Resetting Hot Tank Overload Thermostat 35

MAINTENANCE

- Preventative Maintenance 36
- System Inspection 37
- Warranty Procedure 37

TROUBLESHOOTING

- Troubleshooting Guide 38

SAFETY ALERT SYMBOLS

Read and follow all safety information carefully. The signal words used in this manual are selected as shown below and based on an assessment of the degree of potential injury or damage (severe or minor) and the occurrence of injury (occurs or has the potential to occur) when the warning is ignored:

⚠ DANGER!

Indicates a situation which, when not avoided, results in death or severe injury.

⚠ WARNING!

Indicates a situation which, when not avoided, has the potential to result in death or severe injury; and/or severe property damage.

⚠ CAUTION!

Indicates a situation which, when not avoided, results in or has the potential to result in minor injury; and/or minor property damage.

SAFETY PRECAUTIONS

Basic safety precautions should be followed, including the following:

Ensure all Local, State, and Federal Laws and Codes including health and safety guidelines are met when installing **Wellsys** Equipment. Only qualified service technicians should attempt installation and service of **Wellsys** Equipment. Always read the entire operating instructions before using the appliance and save these instructions for future use.

⚠ DANGER! *This product can cause death or severe injury if incorrectly operated, installed or maintained. The installation, maintenance, sanitizing and any repair must be performed by qualified persons trained by Wellsys International or their approved distributors only. Do not remove any panel or cover to protect against electrical shock and exposure to UV radiation.*

⚠ DANGER! **ELECTRICAL SHOCK HAZARD. *Always use a dedicated and properly grounded outlet. Unit should be protected by ground-fault circuit interrupter (GFCI) or residual current device (RCD) having a rated residual operating current not exceeding 30mA. Use only Wellsys supplied power cord. Never use extension cords or power strips to connect unit. Do not use if the power supply cord is damaged. Always unplug from power supply prior to servicing.***

⚠ WARNING! **AUTHORIZED USE ONLY. *This appliance is to be used for its intended purpose as described in this manual. Untrained individuals who use this manual assume the risk of any resulting property damage or personal injury. This appliance can't be used by children and persons with reduced physical, sensory, or mental capabilities or lack of experience.***

⚠ WARNING! **DO NOT OPERATE IF DAMAGED. *Unplug and isolate water supply if abnormal conditions exist. Contact Wellsys or authorized dealer for repair, service, and installation to avoid hazards.***

⚠ WARNING! **HOT WATER. *Unit produces Hot Water in excess of 80°C (175°F). Water above 52°C (125°F) can cause severe burns or scalding. Keep unauthorized people and children away from the unit to avoid accidental dispensing of hot water.***

⚠ WARNING! **CONNECT TO POTABLE WATER SUPPLY. *This system is to be used for water only and is NOT intended for use where water is microbiologically unsafe or with water of unknown quality without adequate disinfection before or after the system.***

- ⚠ WARNING! TIP HAZARD.** *Dispenser could tip or fall causing serious injury if installed with a base. Always install unit on a firm, flat, and level surface and secure unit to cabinet, wall, or floor if needed and secure to the base, if applicable. Never place heavy items on top of unit and never climb, stand, or hang on unit or storage cabinet to prevent injury and damage.*
- ⚠ WARNING! UNIT IS HEAVY. TWO PERSON LIFT REQUIRED.** *Transport unit empty and always use material handling equipment or two people with proper lifting technique to reduce injury risk.*
- ⚠ WARNING! STORE AND TRANSPORT UNIT EMPTY. ALWAYS SANITIZE BEFORE USE.** *The unit must be completely drained before storing to avoid stagnation and reduce microbiological contamination (potential bacterial growth). Always sanitize before use to eliminate any potential microbiological contaminants.*
- ⚠ CAUTION! INDOOR USE ONLY.** *Never expose to direct sunlight, heat sources, or ambient air temperature above 37°C (100°F) or below 2°C (35°F). Install indoors and keep unit away from excessive humidity or rain. Never expose to freezing temperatures. Ensure there is adequate clearance around the unit to allow refrigeration system condenser to dissipate heat. Warmer environments require more clearance around the unit. Minimum clearance around all surfaces of the machine is 2-inches. Installs where the ambient temperature exceeds 27°C (80°F), require a minimum of 4-inches clearance for proper heat dissipation and efficient operation.*
- ⚠ CAUTION! USE A WATER PRESSURE REGULATOR.** *Wellsys will not be responsible for injury or damage caused by excessive water pressure. Input or feed pressure must be 40 psi to 80 psi. Be aware of any potential pressure surges caused by building/municipal pumping stations. Failure to comply will void all warranties. The manufacturer accepts no liability for damage caused by excessive water pressure.*
- ⚠ CAUTION! USE UV STABILIZED SUPPLY LINES.** *Feed the unit with a potable ambient or cold-water supply only. Feed water over 37°C (100°F) can damage the treatment components. Water block devices and external leak detectors are strongly recommended. Locate the unit as close to the water supply and the electrical connections as possible. Immediately isolate or close water supply valve and contact service representative if leak is noticed.*
- ⚠ WARNING! SECURE CO2 SUPPLY BOTTLE.** *When connecting a CO2 tank to the system, please ensure that the CO2 tank is securely fastened to avoid falling. Failure to secure tank can result in property damage and/or bodily harm.*
- ⚠ WARNING! REFRIGERANT SYSTEM.** *This system is manufactured with 134A refrigerant. Repairs to the refrigeration system must be performed by a certified refrigeration technician only.*
- ⚠ CAUTION! DO NOT PLACE HEAVY ITEM OR WATER CONTAINER ON TOP OF UNIT.** *Water may leak into the electrical system causing a fire hazard. Heavy items may fall off causing injury.*

Contact Wellsys for assistance or help finding an Authorized Service Representative.

S4 FEATURES AND BENEFITS

Hot, Cold, Ambient, and Sparkling Water

The **S4 Water Treatment System** comes standard with Hot, Cold, Ambient, and Sparkling Water Selections to meet a wide range of customer demands.

Water Capacity and Production

The **S4 Water Treatment System** hold 1.25 liters of Hot Water, 0.7 liters of Sparkling Water, and can produce up to 60 liters/hour of Cold Water.

Large Dispense Area with Recessed Faucet

11.16-inch dispense height with recessed faucet to protect from cross-contamination.

Leak Prevention

S4 Water Treatment Systems are supplied with a leak stop device to cut off the water supply in the case of a water leak or overflow.

Hot Water Safety Disable Function

The **S4 Water Treatment System** has a power switch on the back panel that allows the hot tank to be switched off if desired.

Optional Base Cabinet

Available with an optional base cabinet to make free-standing.

Hands-free Touchless Dispense Module

Touchless Dispense Module uses Infrared Technology to activate select and dispensing functions.

ADA Wheelchair Height Compliant

Meets ADA Wheelchair Height Standards when installed in accordance with ADA requirements.

Temperature Indicator Light

Light on dispense nozzle changes color to indicate water temperature being dispensed (Blue for Cold, Red for Hot, Green for Sparkling, White for Ambient)

Drip Tray Drain

Optional Drip Tray Drain connection.

Two Filter Configurations

The Wellsys S4 can use two filter configurations: 4-stage UF (ultra-filtration) and 5-stage RO (reverse-osmosis).

CERTIFICATIONS

S4 Water Treatment Systems have been tested and certified to rigorous NSF and UL Standards. We believe that performance testing and certifications validate **Wellsys** as a world-leader in water treatment systems.

[Wellsys S4 Component Certifications Include:](#)



Intertek

UL399 – Certified Drinking Water Cooler

Intertek Labs (ETL) Certified the **S4 Water Treatment System** to ANSI/UL 399 Standard for Drinking Water Coolers.

CSA C22.2 No. 120 CSA Standard for Refrigeration Equipment

NSF / ANSI 372 – Drinking Water System Components – Lead Content

Drinking Water System Components for low Lead Content.

MODEL/PART DESIGNATIONS

BRAND NAME	DESCRIPTION	MODEL - PART NUMBER
<i>S4 Countertop Unit</i>	<i>S4</i> – Hot, Cold, Ambient, Sparkling CT	S4
	Z14007-(YYMMDD)-00(XXX)	

SPECIFICATIONS

<u>ITEM</u>	<u>S4</u>
Water Connection	¼" Quick Connect
Recommended Service Water Pressure	50psi (max)
CO2 Connection	¼" Quick Connect
Recommended Service Gas Pressure	40-50psi
Rate Voltage	AC 110V/60Hz @ 4.9Amps
Power Consumption	1.36A Compressor ; 150W Hot Tank ; 1.60kWh/24hrs
Power Cord	1.9m (6.3ft)
IP Class	IPX1
Climate Class	N Class (32°C +/- 1°C) (89.6°F +/- 33.8°F)
Safety Device	Overheating protector. Water Level Detector. Leak Stop Device. Fuse.
Hot Tank Size	1.25 Liters (42.3oz)
Ice Bath Volume	6.0 Liters (202.8oz)
Sparkling Water Volume	0.7 Liters (23.7oz)
Environmental Temperature	Max: 90°F (32°C) Min: 35°F (2°C)
Source Water Temperature	Max: 90°F (32.2°C) Min: 40°F(4.5°C)
Relative Humidity	55% at 78°F(25.5°C)
Refrigerant Gas	R134a (46g +/-1g)
R134a Pressures	280psig (19.3bar) (High Side)

SHIPPING SPECIFICATIONS

ITEM	S4
Width/Depth/Height	360mm W x 567mm D x 453mm H 14.2"W x 22.3"D x 17.8"H
Weight (dry)	57.3lbs. (26.0 kg)

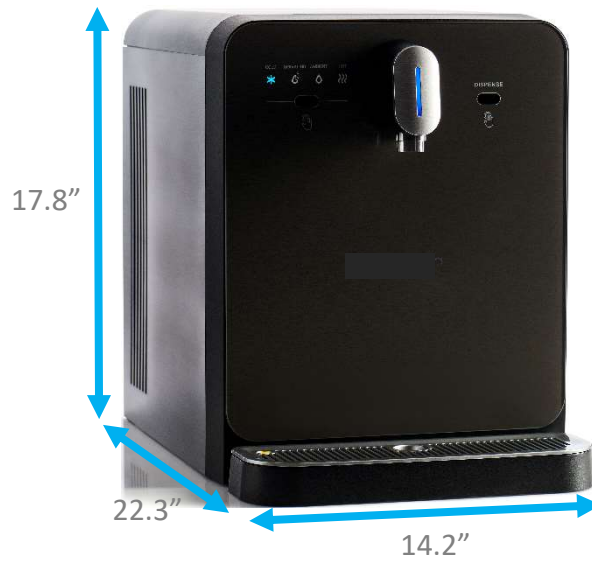

RECEIVING YOUR EQUIPMENT

Upon receipt of your equipment, you should check the following:

1. Are the systems still on the pallet?
2. Confirm the number of boxes you are signing for.
3. Is there any obvious damage to the product or the boxes?

If there are any discrepancies or any obvious damage to the equipment or boxes, please note it on the "Bill of Lading" and/or refuse the shipment.

After receiving the equipment from the carrier, remove packaging and inspect for any hidden freight damage. If freight damage has occurred, call the freight company and customer service (877) 386-0823 to report the damage. Photograph all damages to be submitted with the claim. **THIS MUST BE DONE WITHIN FIVE BUSINESS DAYS OF DELIVERY.** If not reported within 3 business days, Wellsys and/or carrier will not be responsible for replacement or repair.

DISPLAY & CONTROL PANEL

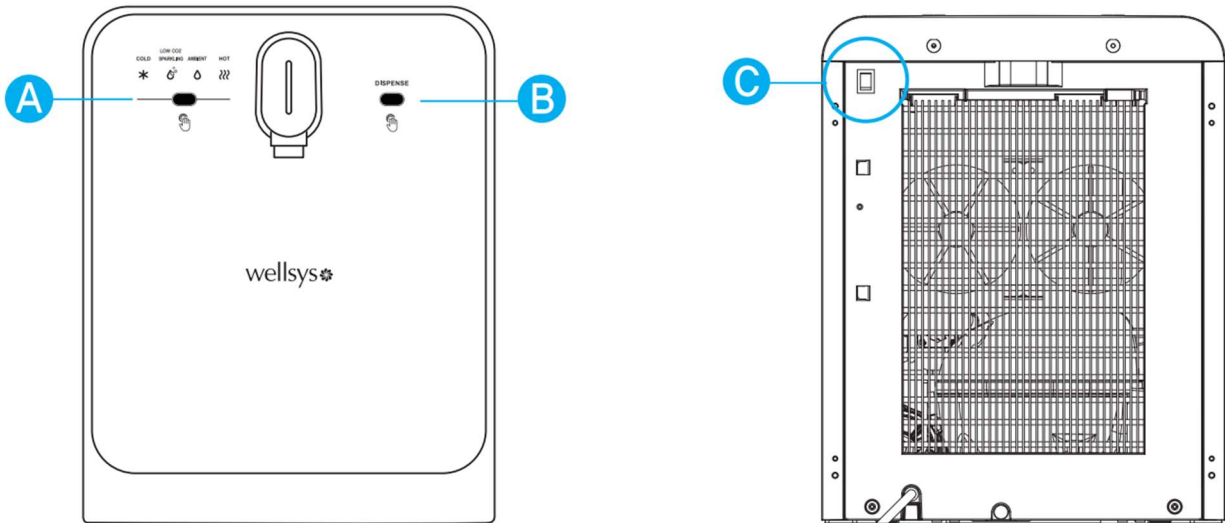

<p>COLD</p>	COLD WATER LED	COLD WATER LED is on when the ambient water is selected. (Blue)
<p>SPARKLING</p>	SPARKLING WATER LED	SPARKLING WATER LED is on when the ambient water is selected. (Green)
<p>AMBIENT</p>	AMBIENT WATER LED	AMBIENT WATER LED is on when the ambient water is selected. (White)
<p>HOT</p>	HOT WATER LED	HOT WATER LED is on when the ambient water is selected. (Red)
<p>LOW CO2</p>	LOW CO2 LED	LOW CO2 LED is ON when the CO2 is exhausted. (Green)
<p>A</p>	TOUCH FREE SELECT SENSOR	Selecting the Cold/Sparkling/Ambient/Hot Water in order.
<p>B</p>	TOUCH FREE DISPENSE SENSOR	Dispensing the selected water. (Cold/Sparkling / Ambient/hot)
	WATER DISPENSE SPOUT	Water is dispensed from WATER DISPENSE SPOUT.
<p>C</p>	HOT WATER ON/OFF SWITCH	Press the switch up or down to set/cancel the HOT WATER.
	LOW CO2 ALERT	Low CO2 alert when CO2 pressure drops below 2bar.

OPERATING INSTRUCTIONS

The below pictures show the front user interface (UI) and control panel for the **S4 Water Treatment System**.

- To Select Water:** Place your hand close to the TOUCH FREE SELECT SENSOR (Left Sensor). Move your hand away and back to the sensor to select the next option. **Cold Water → Sparkling Water → Ambient Water → Hot Water** is the selection order.
- *Your hand should be 3-4cm away from the sensor to activate.
 - *Move your hand back and forth to cycle, OR hold your hand over sensor and the selection will change automatically every 1 second.
 - *If the sensor does not detect motion for more than 5 seconds, it will switch to the default mode (Cold Water).

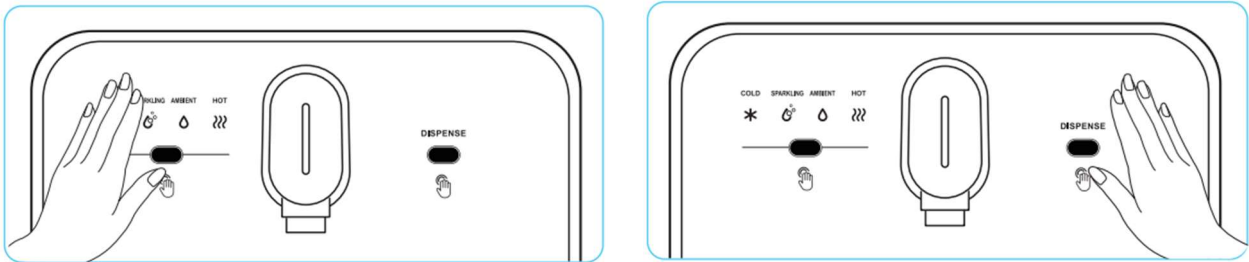

- To Dispense Water:** Place your hand close to the TOUCH FREE DISPENSE SENSOR (Right Sensor) and hold there to dispense. Remove your hand to stop.
- *If both sensors (SELECT & DISPENSE detect any motions simultaneously, then the unit will recognize this as an error and will not operate.
 - *After dispensing the Sparkling Water, some residual bubbles might remain in the internal water path and affect the taste of the next water dispensed.

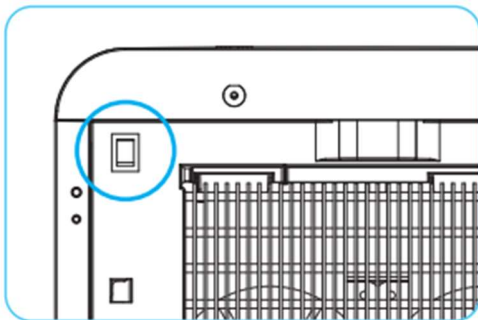

- *Hot water ON/OFF switch is located on the back of the product. In order to disable the Hot Water Function, flip the switch into the OFF position.

WELLSYS MANUFACTURED WATER TREATMENT SYSTEM LIMITED WARRANTY

***Refer to the dealer agreement for warranty terms.**

General Provision and Exclusions:

This warranty only applies in the fifty (50) United States and Canada. This warranty does not apply, and no agreement, either written or implied, shall be applicable if the affixed serial number is removed, defaced or obliterated. This warranty does not apply to the filters or Ultra Violet system after exposure to water. Refer to service manual for filter requirements and expected performance. This warranty does not apply if parts used as original or replacement equipment, including filters, are not obtained or authorized through WELLSYS, and such unauthorized usage shall void this warranty. This warranty does not apply to any wetted parts that become inoperative due to lime, scale or other water quality conditions. This warranty does not apply to any machine or components that become inoperable due to a failure by Dealer/Distributor or the end-user to satisfy standards or regulations adopted by any governmental agency. This warranty does not cover performance, failure or damages of any part resulting from external causes such as alterations, abuse, misuse, misapplication, neglect, accident, installation, operation contrary to printed material, corrosion or acts of God.

This warranty only applies to the operative components of the machine and does not apply to the exterior shell or frame to which the shell is attached and the appearance of the machine.

This warranty and any applicable industry certifications for this machine are automatically voided if the machine is altered, modified, or combined with any other machine, equipment or device. Alteration or modification of the machine may cause serious flooding and/or hazardous electrical shock or fire. Except as set forth herein, WELLSYS makes no other warranty, guarantee or agreement expressed, implied or statutory, including any implied of merchantability or fitness for a particular purpose.

The foregoing is in lieu of all other agreements expired or statutory and all other obligations or liabilities of WELLSYS. WELLSYS does not assume or authorize any person to assume any obligations of liability in connection with this product. In no event will WELLSYS be liable for special, incidental, consequential or punitive damages, or for any delay in performance of this warranty agreement due to causes beyond its control.

Export Warranty:

The WELLSYS export warranty shall apply to all area outside of the Continental limits of the United States and Canada. The export warranty shall mirror the domestic warranty set forth above in all respects except that a) the export warranty shall be limited to the Initial Term and there is no coverage for the additional warranty through the fifth year and b) the Dealer/Distributor shall be responsible for any and all transportation charges to implement the repairs.

ALL WARRANTY REPAIRS SUBJECT TO PRIOR APPROVAL BY PURE WATER TECHNOLOGY'S SERVICE DEPARTMENT IN ORDER TO VALIDATE THAT THE DEFECTIVE COMPONENT IS STILL UNDER WARRANTY.

SERVICE REQUIREMENTS

⚠ WARNING! *Read and understand the contents of this manual before attempting to service the S4 Water Treatment System. Failure to follow the instructions in this manual could result in death, serious personal injury, or severe property damage. Only trained and qualified technicians should attempt to install, maintain, or service Wellsys Equipment.*

1. Visually inspect all electrical and water connections for signs of wear or damage.

⚠ DANGER! *HIGH VOLTAGE ELECTRICAL HAZARD. Unplug before inspection and service.*

⚠ WARNING! *ULTRAVIOLET RADIATION. Protect your skin and eyes against ultraviolet rays. Never look directly at an operating UV light. Disconnect before removing UV Lamp.*

⚠ CAUTION! *UV LIGHTS ARE HAZARDOUS. Lamps are considered Hazardous Waste and must be disposed of accordingly. Refer to Product MSDS sheet for details.*

2. Ensure there is adequate (minimum of 2") clearance around the **S4 Water Treatment System** and clean the condenser grill and compressor fan to provide efficient cooling system operation.

3. Sanitize the unit per instructions in the sanitization procedures.

⚠ WARNING! *SANITIZER MAY CONTAIN HAZARDOUS CHEMICALS. Use of proper personal protective equipment such as rubber gloves and eye protection are required.*

4. Clean and sanitize external surfaces of the **S4 Water Treatment System**. Use soap and water or chemicals that are compatible with ABS plastic and will not damage or degrade the product surfaces.

5. Remove and clean the Faucet. Replace as needed.

6. Descale Hot Tank Annually, or as needed.

7. If using filtration, flush in filters per instructions, and change filters on predetermined schedule, commonly every 12 months for standard filters.



S4 PARTS LIST

No.	Part No.	Description	Rec' Stock	Photo
1	31-0490-2	BASE PLATE FOOT	0	
2	11-1546-1	LEAK STOP FLOAT VALVE	2	
3	41-2048-0	POWER CORD PLUG	0	
4	41-2180-0	BOOSTER PUMP	1-2	
5	41-2092-0	FAN MOTOR	0	
6	41-2055-0	HOT TANK POWER SWITCH	1	
7	11-3264-0	SHUT-OFF FLOAT	1	
8	41-1201-1	TEMPERATURE SENSOR – COLD TANK	1-2	

9	41-1678-1	AGITATOR MOTOR	2-3	
10	11-3034-1	MIXER	2-3	
11	41-1194-2	HIGH PRESSURE SOL V/V	2-3	
12	41-1449-2	SPARKLING SOL V/V	2-3	
13	41-1768-4	HOT WATER SOL V/V	2-3	
14	41-1448-1	PRESSURE SWITCH 2K (WHT COLLET)	1	
15	41-2198-0	PRESSURE SWITCH 6.5K (RED COLLET)	1	
16	41-2274-0	PRESSURE SWITCH WIRE	0	

17	41-1432-2	WATER LEVEL SENSOR (2 PIN)	1-2	
18	91-4119-0	HOT TANK ASSY	0-1	
19	11-1088-0	¼" RESTRICTOR FITTING	1-2	
20	91-4247-0	MANIFOLD FAUCET ASSY	0-1	
21	51-0347-1	6" SEDIMENT AIR FILTER	Change every 24mo	
22	11-3268-0	¼" SPARKLING FLOW CONTROL	1-2	
23	11-0978-3	¼" RESTRICTOR FITTING	1-2	
24	11-2044-0	¼" CHECK VALVE	0-2	

25	41-2268-0	MAIN PCB	1	
26	21-0627-0	GAS SAFETY VALVE	0	
27	91-4111-0	FRONT COVER ASSEMBLY	0	
28	41-2269-0	FUNCTION PCB	1	
29	41-2271-0	LOGO PCB	0-1	
30	41-2145-0	IR SENSOR	2	
31	91-4288-0	DECO FAUCET COVER ASSY	0	
32	91-3646-0	DECO FAUCET ASSY	0	

33	11-3271-0	SIDE COVER	0	
34	11-3272-0	TOP COVER	0	
35	91-4112-0	DRIP TRAY ASSEMBLY	0	

S4 WATER FLOW DIAGRAM

< SPARKLING WATER FLOW >

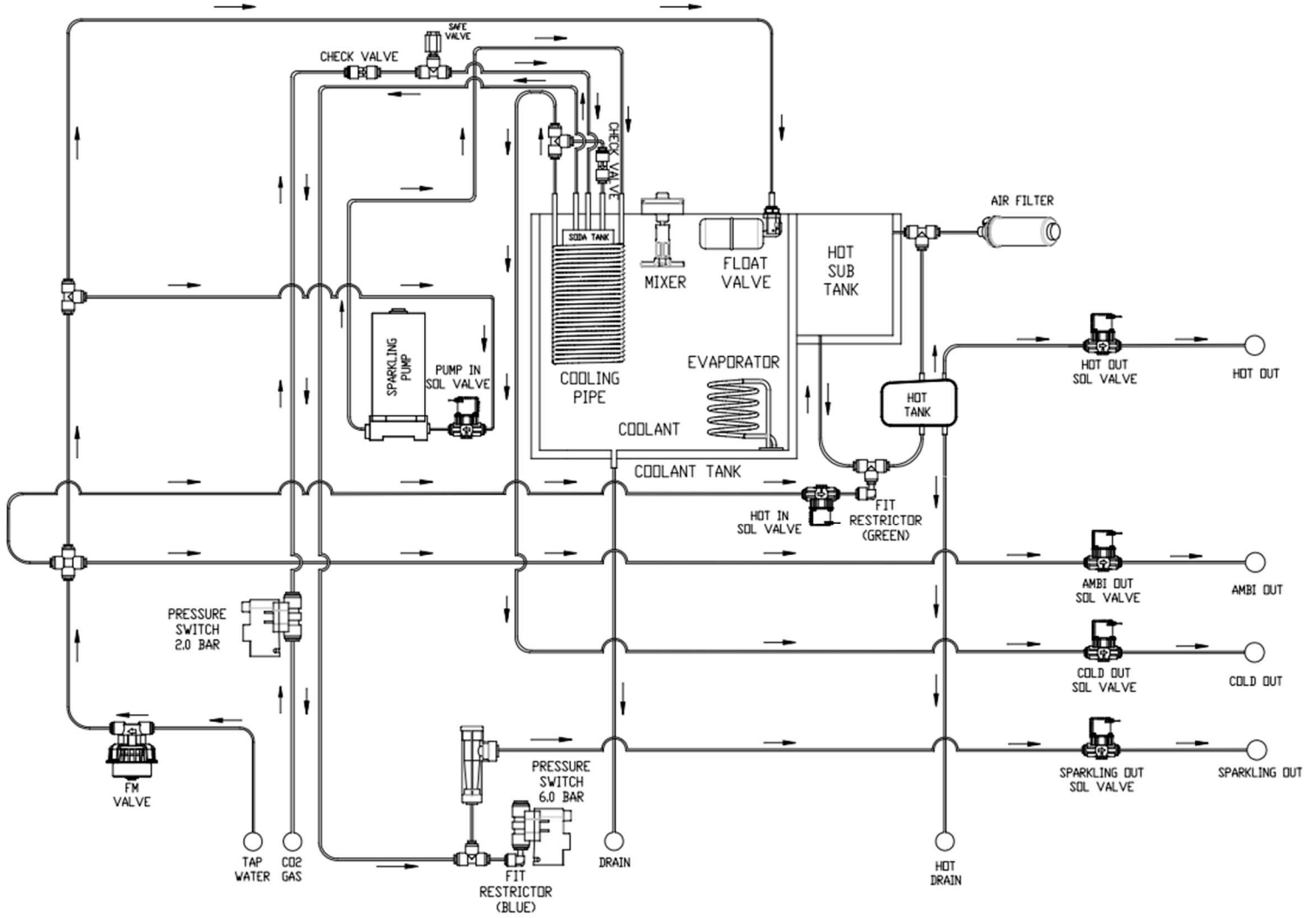

S4 PCB DIAGRAM

⚠ DANGER! HIGH VOLTAGE ELECTRICAL HAZARD. PCB (Printed Circuit Board) contains High Voltage. Only trained and qualified technicians should attempt live testing.

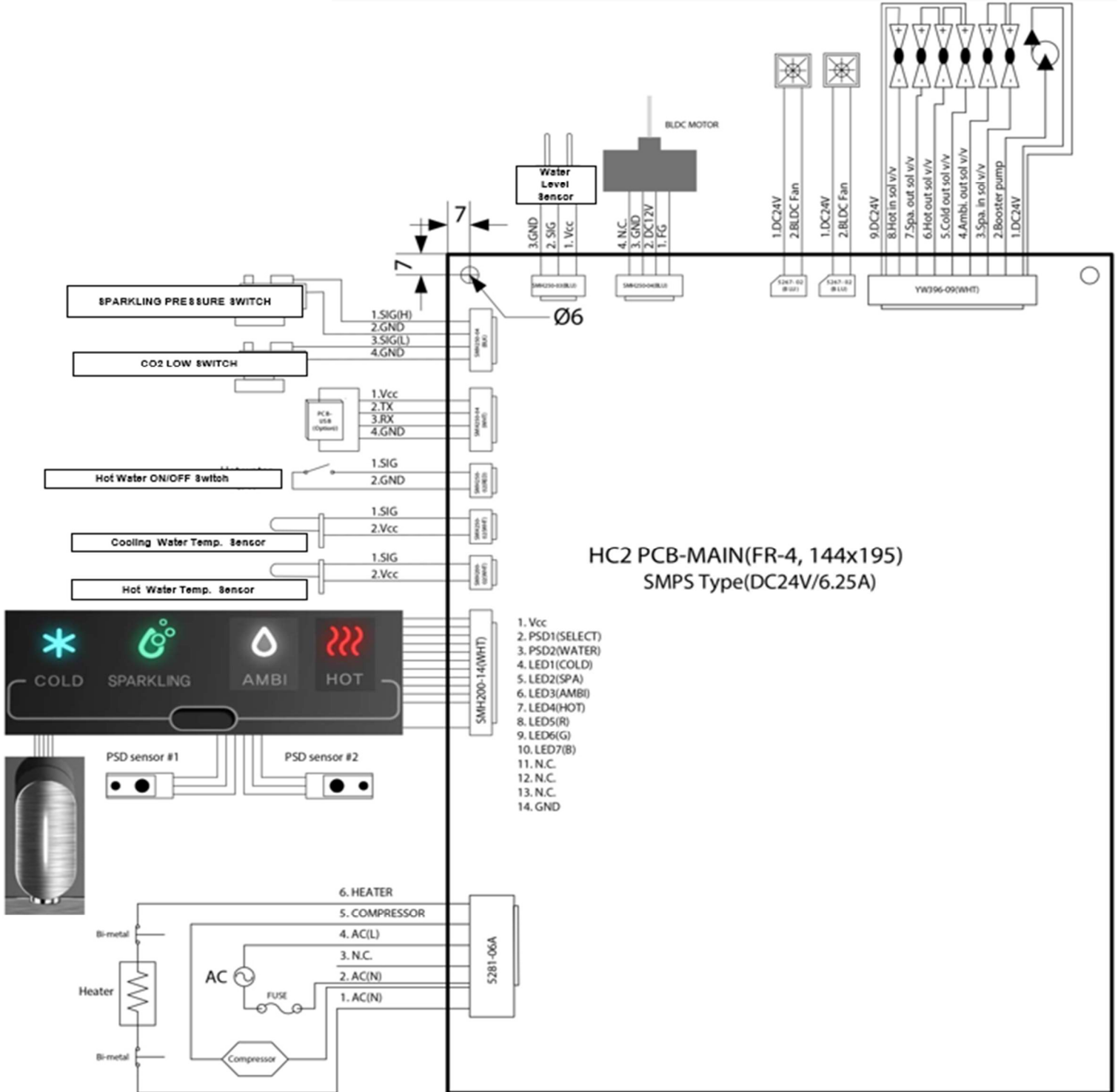

S4 ELECTRICAL DIAGRAM

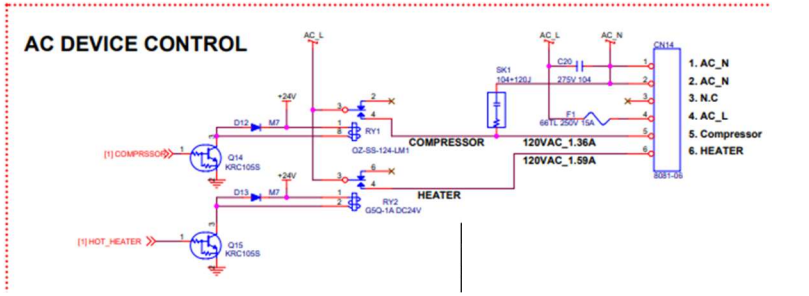
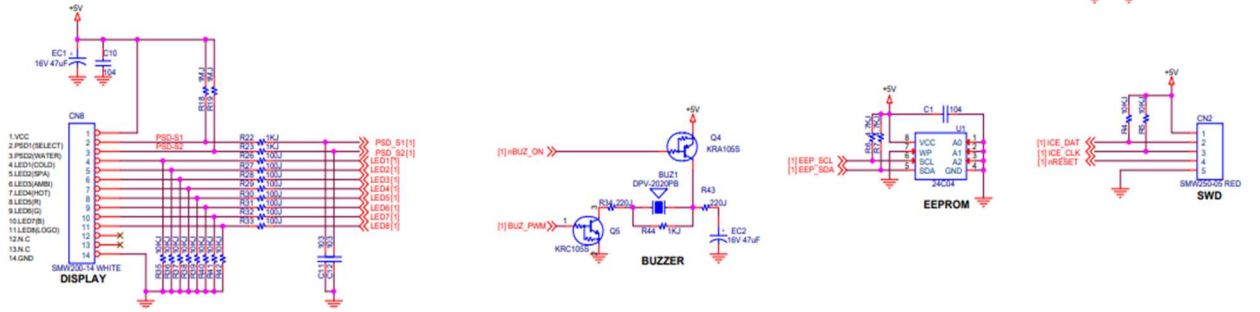
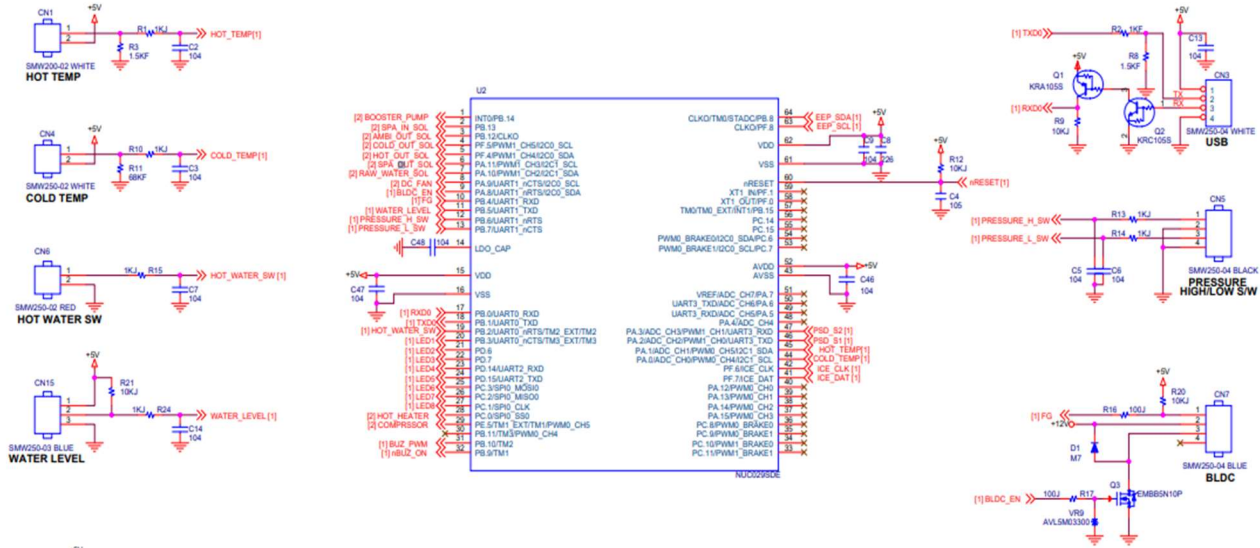

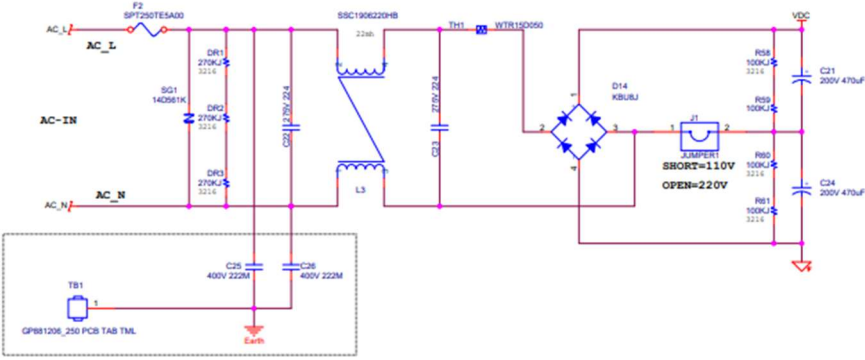

110V/220V SMPS

	110VAC	220VAC
C21	200V 470uF	400V 180uF
C24	200V 470uF	Short (Jumper)
J1	Short (Jumper)	OPEN

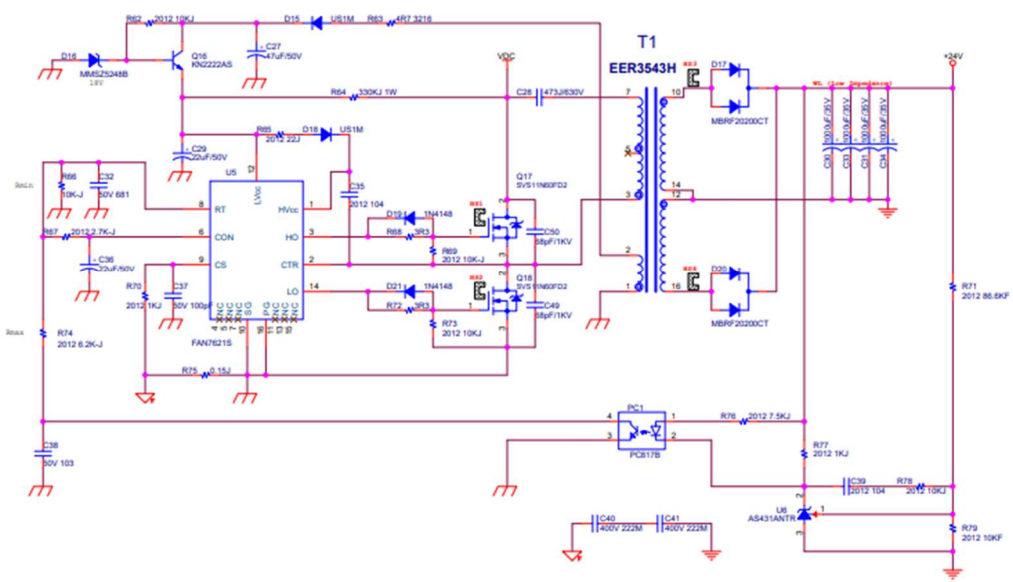

PRE-INSTALLATION



DANGER! ELECTRICAL SHOCK HAZARD.

*Only qualified personnel who have read and understand this entire manual should attempt to install, or service this **S4 Water Treatment System**, failure to do so could result in death or serious injury. DO NOT plug into an electrical supply until specifically instructed.*



WARNING! ALWAYS SANITIZE BEFORE USE.

Sanitize before use to eliminate any potential microbiological contaminates.

Materials Needed:

- Personal Protective Equipment. Rubber or Nitrile Safety Gloves and Protective Eyewear
 - Phillips Screwdriver
 - Temperature Gauge
 - Water Pitcher or Container to collect water from the faucet
 - 5-gallon container or drain basin
 - Sanitizer - Household Bleach (5.25% Sodium Hypochlorite) or Citric Acid Based Cleaner
 - ¼" Plastic Tubing, at least 10 feet in length, and assorted ¼" quick connect fittings
 - TDS Meter and Test Strips for measuring chlorine – Optional
1. Unpack the **Wellsys S4 Water Treatment System** and check exterior for damage.



CAUTION! FILTER FLUSH REQUIRED.

S4's Water Treatment Systems are not supplied with filters. Filters should be configured to optimize your system. Filters need to be configured and specified to do the job given the local water conditions, usage, maintenance schedule, and placement restrictions.

In order for our filters to perform as represented and to provide the best quality water possible, it is essential that filters be replaced periodically. The frequency of filter changes depends upon your water quality and your water usage. For example, if there is a lot of sediment and/or particles in your water, then you will have to change your filters more frequently than a location with little to no sediment. Be sure to replace your filters whenever you notice a decline in the performance, whether it is a drop in flow rate and/or pressure or an unusual taste in the water.

2. Flush thoroughly per filter manufacturers' recommendation with fresh water to drain. More details provided in the **Filter Flushing** section further down.
3. Once flushed, install the filters. Following the flow direction on the filter.
NOTE: Filters should not be flushed prior to 24 hours before installation to limit Microbial Growth.

NOTES ON INSTALLATION

1. Do not install the product at the following locations:
 - Near Fires
 - Near Flammables
 - In Humid Places
 - In front of air conditioners
 - Where exposure to rain or snow is possible
 - Outdoors or in direct sunlight
 - Near chemicals (volatile materials, organic solvents, etc.)
 - Near toilets
 - Anywhere the temperature may fall below 50°F.
2. Use source water within following quality range:
 - Water pressure: 1-3.5kgf/cm² (103-345 kPa)(15-50psi)
 - Water temperature: 39-100°F (4-38°C)
 - Turbidity: 0.5 NTU or less
 - pH: 5.8-8.5
 - Hardness: 300ppm or less
 - Water Quality: Water quality meeting the Drinking Water Quality standard

*Please consult your distributor if source water quality is out of the specified range.

*The warranty will be void if the product is connected to source water that is out of the specified range.

*This product is not equipped with internal filtration. It is intended to be connected only to a potable water source.

3. When transporting the product, do not tilt it more than 45° from vertical.
 - *Severe tilting can cause a performance degradation.
4. Install the product on a flat surface and adjust the level of the unit using a level gauge.
 - *If the product is tilted more than 3°, overflow may occur.
5. Source water should not be above 100°F (38°C)
 - *Hot water may cause performance degradation or system failure.
6. Keep the sides and rear of the unit at least 5 inches (127mm) away from walls or other objects for ventilation.
7. Do not bend the source water hose or place heavy objects on it.
 - *If it is blocked, the water will not flow smoothly to the unit, and may cause performance degradation.
8. Do not place any heating system near the rear of the unit.
9. The power supply and source water must be directly connected to the unit.

INSTALLING THE CO2 TANK

The S4 produces sparkling water, thus it requires a CO2 supply to create it. Commonly, CO2 is supplied using a steel tank pressurized with CO2 gas paired with a valve and regulator. This section outlines how to properly set up a CO2 supply to the S4. For this guide, it is assumed you already have a CO2 bottle fitted with a manual valve.

CO2 Bottle and Regulator Overview

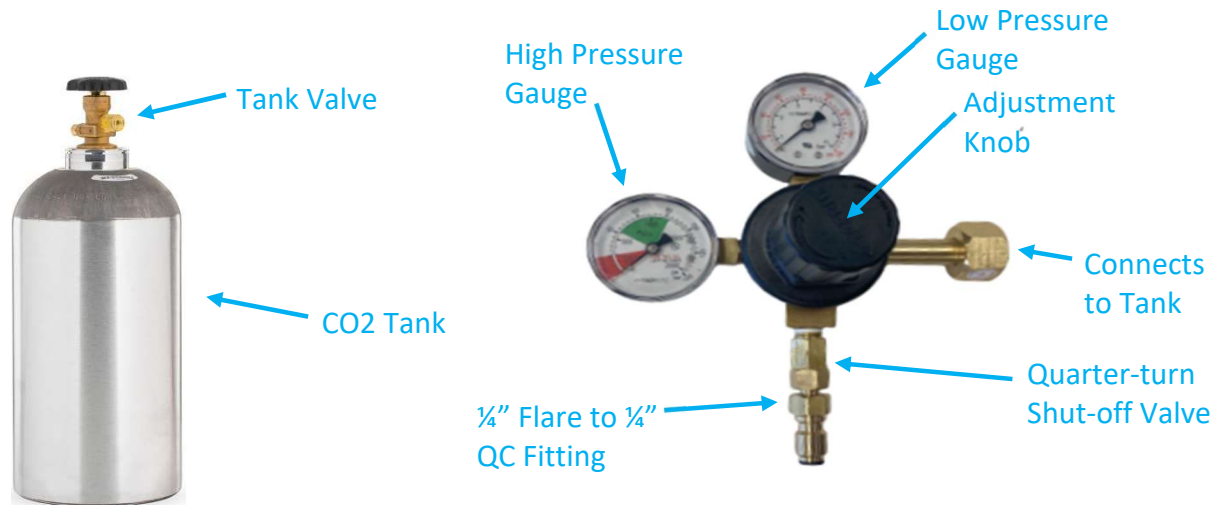

1. Use an adjustable wrench to install the regulator tightly to the CO2 Valve. **Be aware there should be a nylon washer zip-tied to the valve connector of the pressure regulator. Cut this washer free, remove the zip-tie, and place the washer inside the valve connector before installing on the tank valve.**
2. Connect several feet of 1/4" poly tube (LLDPE) to the regulator. This will later be used to make the gas connection to the unit. **If you do not have a shut-off valve on the regulator, install a ball valve to the end of the poly tube. Keep the ball valve closed, and do not open tank valve until this has been done.**
3. With the quarter-turn shut-off valve on the regulator closed, or the ball valve at the end of the poly tube closed, open the valve of the CO2 Tank.
4. Turn adjustment knob clockwise to raise pressure, counter-clockwise to lower pressure.
5. Set pressure 1bar more than water pressure to the unit (max pressure is 4 bar).
6. No Teflon tape is needed for flare fitting.
7. The gas bottle is ready to be placed into its storage area and connected to the unit when ready. **Gas bottles should always be secured to avoid tipping.**

INSTALLATION

It is very important to follow all instruction listed. Failure to do so may cause the system to not operate properly and may impact the long-term reliability of the system. **DO NOT turn on the Hot Water switch at back of unit until the Hot Water tank has been primed with water.**



1. Always check local plumbing codes before tapping into water supply line and drain line. Tap into the water source with an approved connector.
2. Check incoming water pressure and ensure it is 50PSI max. If the water pressure is above 50PSI then a pressure reducing valve must be installed and set to lower the pressure to the optimal water pressure below 50PSI.
3. If using filters, flush/rinse them now in accordance with the flushing instructions.
4. Once the filtration system flushing procedures are complete, determine the best installation location. Consider user convenience, electrical access, and water access. The unit performs optimally if within 2- feet of a cold-water supply line. Connect only to a cold-water supply. Do not install Feed Water Assembly on the Hot Water Line. Do not place unit where it will be exposed to rain, freezing temperatures or direct sunlight.
5. The rear of the unit should be installed at least 2” from any vertical surface to ensure proper air circulation.
6. Check the available power supply to assure proper electrical service. In the U.S., the voltage specification is 110/120V 60Hz. Voltage outside of this specification will affect the system performance.
7. Connect the blue water supply line on the back of the unit to the product water from the filtration system using poly tube (LLDPE tubing), or to the water source if not using filtration. Turn the water supply on.
8. Connect the black gas line on the back of the unit to the CO2 line from the gas bottle regulator. Open the gas valve on the bottle and open the quarter-turn valve on the line, or the quarter-turn valve on the regulator (whichever option is installed).
9. With the 60PSI going into the system after 30 minutes, the TDS of the water should be reduced approximately 98% after the RO membrane vs. the incoming tap TDS.
10. Allow the system to fill. This should take 5-10min with UF or about 30min with RO.

11. Prime the Hot Tank by dispensing hot water from the front of the unit until water begins to flow. Once complete, turn on the red Hot Tank switch on the back of the machine. This will enable the heating process for Hot Water feature. **In the event that the hot water switch is turned on BEFORE the hot tank is primed, it is likely that a “dry heat” event will occur. The hot tank, empty of water, will begin to heat rapidly and trip the overload thermostat on the hot tank. This overload will have to be manually reset for the hot tank to operate correctly. The overload thermostat is located ON the hot tank itself, and the red reset button must be pressed to manually reset and restore operation to the hot tank. If this must be done, do so with the unit disconnected from power.*



12. The S4 **WILL NOT** dispense sparkling water until the temperature in the ice bath has reached 41°F. This may take up to an hour to reach temperature, at which time sparkling will become selectable as a dispense option.

How to Assemble the Water Tray

Push the water tray onto the unit until you hear a “click” sound.

**This machine has an audible “beep” indicator when the water or ice is dispensed. To turn off the “beep” sound, simultaneously press and hold for 5 seconds both the HOT WATER and AMBIENT WATER select buttons until all LED indicators flash 5 times. To enable the “beep,” repeat the same process.*

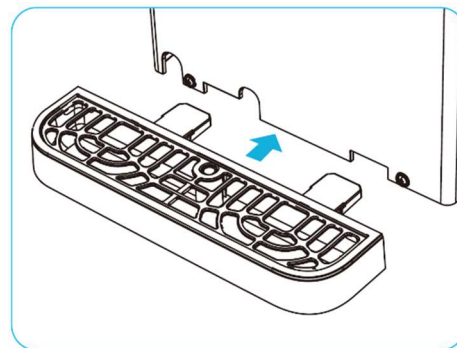

Stand Fastening

1. Remove the Drip Tray of unit and the Front Cover of Stand.
2. After placing the unit on the Stand, place your hand behind the Stand to secure the M6 hex bolts (x4).
*After tightening, ensure it is stable and there is no danger of tipping or falling.
3. Once fixed, return the Drip Tray of unit and the Front Cover of Stand.

*If holes on the top of the base do not line up with the holes on the bottom of the unit, holes may need to be drilled to accommodate the unit. Refer to the Base Hole Modification section further down in the manual.

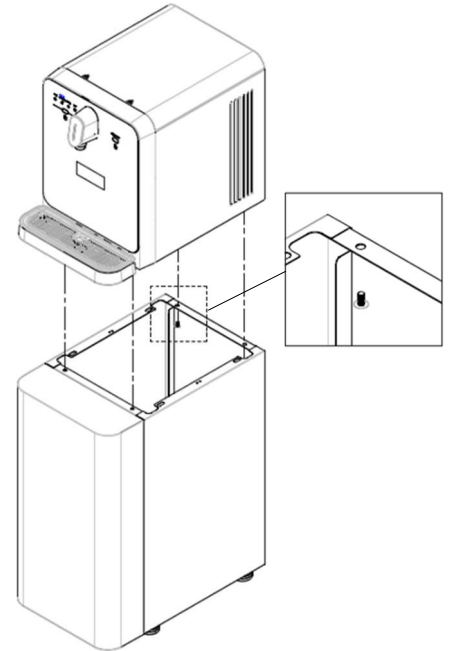

Bracket Fastening

1. Place the bracket on the wall at the installation site and mark the positions (x2).
*There is only one bracket that could be fixed on the top or bottom side of the Stand.
2. Drill two holes in the marked position to fix the bracket to the wall.
3. Ensure the unit is fixed with the wall-mounted bracket, so that the unit does not fall if pushed.

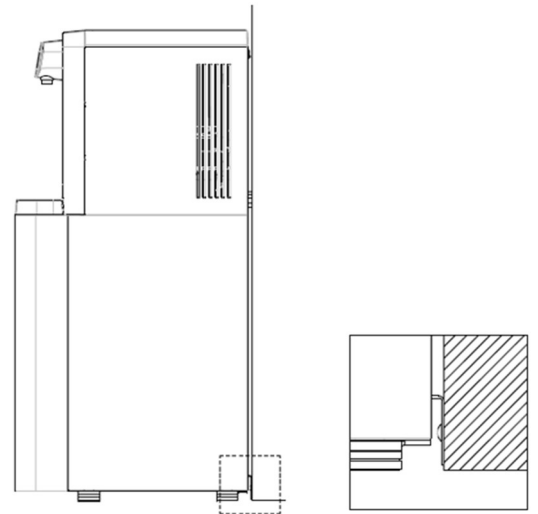

SANITIZING

Sanitize the reservoir using a Hydrogen Peroxide or another approved cleaner. Follow all instructions on sanitizing and flush with fresh water through the drain until odor and taste is acceptable.

⚠️ WARNING! USE PROPER PERSONAL PROTECTIVE EQUIPMENT

Always ensure proper ventilation and use proper personal protective equipment such as gloves and eye protection when using chemicals. Refer to Material Safety Data Sheet for specific requirements of each chemical product. Take all necessary precautions to prevent sanitizer from contacting eyes, clothing, and any other surfaces in could damage (carpets).

⚠️ DANGER! ELECTRICAL SHOCK HAZARD.

Do not plug in unit unless qualified. Only qualified personnel who have read and understand this entire manual should attempt to install or service this unit.

⚠️ CAUTION! NEVER TURN ON HEATER BEFORE FILLING HOT TANK.



Flushing the Reservoir and Hot Tank

During the following steps you should check for any leaks or loose fittings.

1. Turn the water to the system on, plug the system in and let the reservoir fill. RO systems will fill in 1-2 hours and UF systems will fill in 5-10 minutes.
2. Wave hand over “Dispense” to ensure water dispenses from Cold. Wave hand over “Select” until Hot is selected and front LEDs change to Red. Wave hand over dispense again while the dispense light is red and ensure water dispenses from the Hot tank (it will not be hot yet, as you have not turned on the Hot tank switch).
3. Place a pitcher or bucket under the dispense nozzle and dispense about 1 gallon of water from the machine using cold and ambient dispense.
4. Located behind the front panel is a hot tank drain. Have a bucket ready below the unit to catch the water about to drain from the machine. Remove the cap and insert the supplied drain tube with double gasket fitting into the drain fitting, routing the other end to a bucket. The drain port will open once the fitting is inserted. Allow the system to drain until water flow stops.
5. Remove the drain line and allow the system to fill again. Drain one more time to rinse any cleaning agent from the system.
6. Remove the drain line from the drain port and restore the cap to its original position.

Water Dispensing Spout Cleaning Method

1. Turn the water dispense faucet to the left, unscrew from spout and remove.
2. Wipe the inside of the faucet with a soft cloth and cleaning agent.
*DO NOT use detergents, thinners, benzene, or wax for cleaning. This may cause discoloration or peeling off and may cause health problems.
3. After cleaning, assemble the water dispense spout by turning it to the right and screwing it back on.

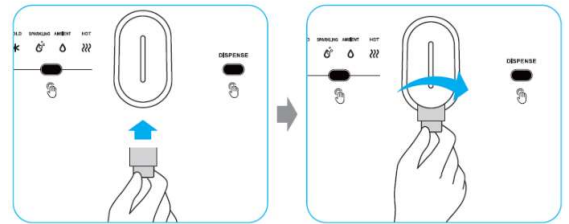
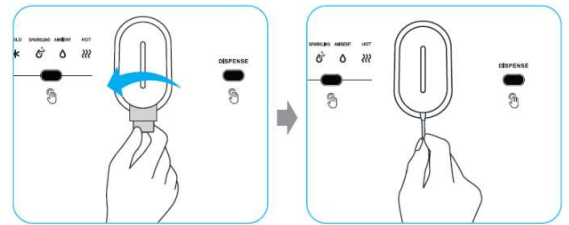

Drip Tray Cleaning

1. The float rises when the drip tray is full of water.
2. Pull the drip tray out for cleaning.
3. Clean up the drip tray with soft cloth or sponge with running water and approved cleaning agent. Dry off.
4. Push the drip tray back into the unit.

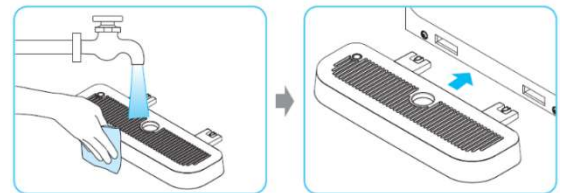
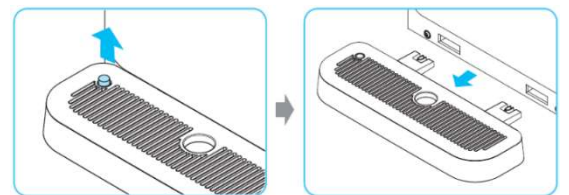

Drip Tray Cleaning

1. Use a screwdriver to remove the 4 screws on the back of the unit.
2. Slide the top cover back to remove it.
3. Remove the left panel by loosening one screw.
4. Gently press the side panel in and slide it back to remove it.
5. Open the coolant drain hose plug and drain the coolant to a bucket. *The Ice Bath hold about 6L of water.
6. Once drained, reassemble in reverse order of removal.

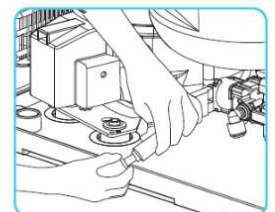
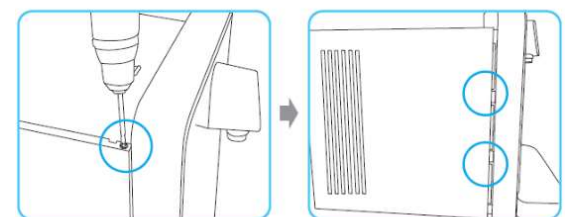
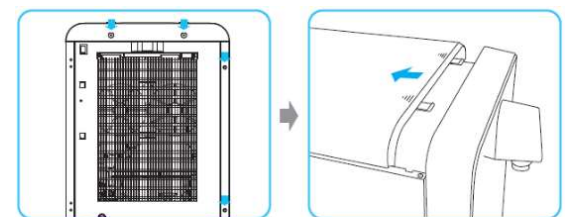

FINAL INSPECTION

After installation and sanitization, verify the following:

1. There are no leaks or loose components.
2. The hot water is over 160°F.
3. The cold water is below 50°F.
4. Confirm acceptable product water flow.
5. If using the Wellsys S4 RO filtration setup, system should fill at a rate of about 5.1L/min.
Note: Incoming water pressure and the drain correctly functioning will have a significant impact of water flow. The flow will also improve as the membrane breaks in.
6. If using the Wellsys S4 UF filtration setup, system should fill in about 5-10min.
7. If the system is not filling, then check the water supply and also make sure the leak stop has not been tripped. ***The leak stop can be reset by removing the cap below the unit and draining the water out.**
8. Ensure the systems exterior is clean and all components are in place.

Other items to check:

1. Once the system has been flushed it should remain plugged in and water should, at a minimum, be dispensed occasionally. ***Avoid storing in your vehicle or warehouse with residual water in the tank, this will result in a bad taste after installation.**
2. Always drain the system before moving it. It is not necessary to drain the hot tank completely through the rear hot tank drain if installing the same day. Leaving water in the hot tank will allow you to turn the hot tank on immediately after installation of the system but if left overnight may result in a taste complaint.
3. Never lay the system on its side.

BASE HOLE MODIFICATION

Some base stands for the S4 do not have the mounting holes present required to secure the head unit (S4) to the base. This section will outline the procedure and provide a template for identifying the location for holes to be manually drilled, to allow the S4 to be mounted to the base.

Mark holes to be drilled using the template below. Use a 3/8" bit to drill the holes. All measurements are marked from outer edge of top frame.

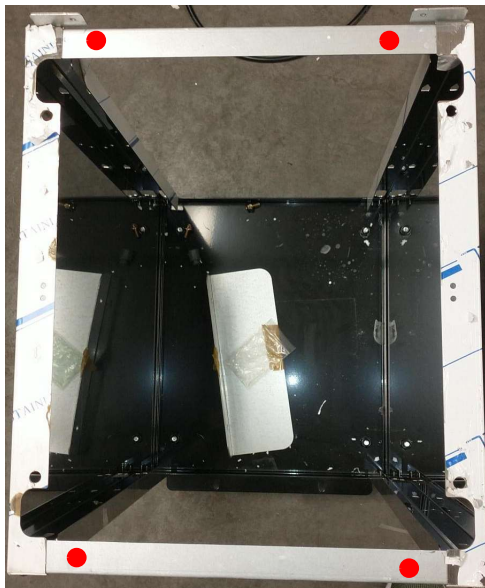

FRONT

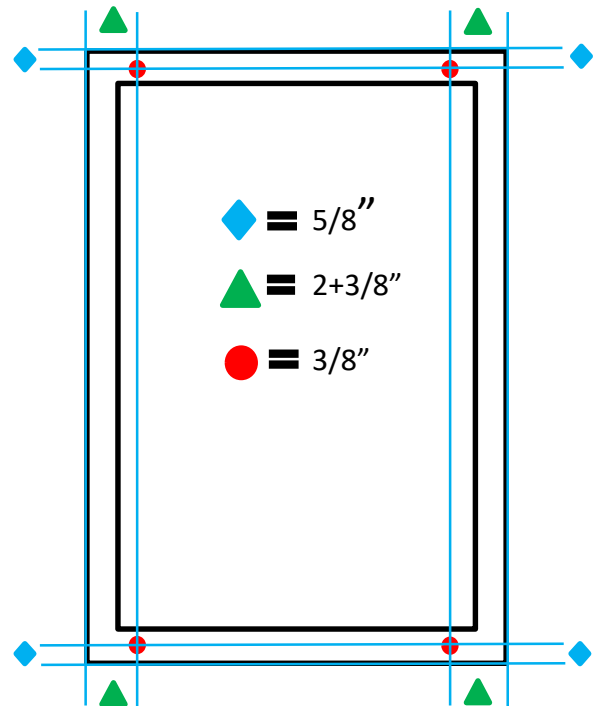

Once the holes have been drilled out, the hole pattern should resemble this view.

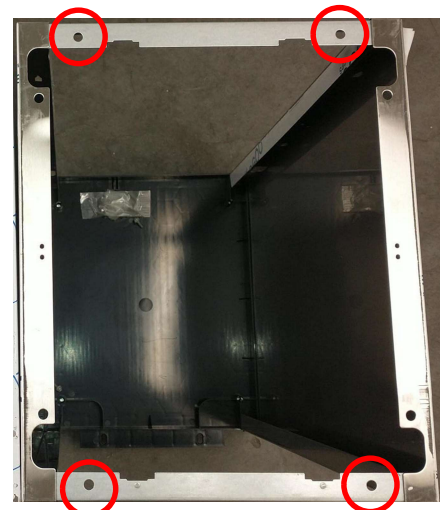

FRONT

RESETTING THE HOT TANK OVERLOAD THERMOSTAT

In the event of a “dry heat” scenario during installation, or if the water supply is blocked to the hot tank, overload thermostats are installed on the Hot Tank to prevent an unsafe heating situation and prevent damage to the unit. If these thermostats sense heat that is too high, they will trip and break the power circuit to the heating element. When this happens, the Overload Thermostat must be manually reset.

CAUTION!: Disconnect the machine from its power source before attempting the next steps. Failure to do so could cause electrical shock.

To do this, remove the upper and side panels of the unit and locate the hot tank. On the surface of the hot tank, where a section of insulation is cut away, the overload thermostat is mounted to the metal round of the tank. There is a small red/pink button in the center of the thermostat that must be pressed to reset the thermostat. Doing so will restore a continuous path for power to reach the heating element. Before doing so, ensure that water dispenses from the unit during the hot water dispense operation. If water flows from the hot tank, the tank is primed and full of water. Continue with resetting the thermostat. Water will begin heating, and hot water should be available within 5-10 minutes.

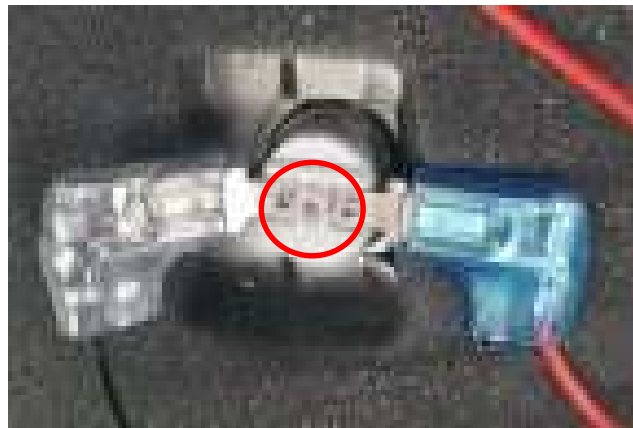

PREVENTATIVE MAINTENANCE

The following is an outline of preventative maintenance that should be performed on yearly or semi-yearly basis to keep the unit running in top shape.

If using filters, change filters according to the filter change schedule. Always rinse new filters using the same procedure as the original filters.

Descal the hot tank using the guide below:

- a. Dispense 4L of ambient water into a container and set aside for later use.
- b. Turn the power off.
- c. Remove the Top and Front Cover of the unit.
- d. With a bucket or pitcher ready, connect the drain hose to the drain port and drain the water from both the hot and reservoir tanks.
- e. Disconnect the drain hose.
- f. Open the reservoir cover, slowly pour 2L of descaling solution into reservoir.
- g. Wait 30min for the solution to descale the tank.
- h. Connect the drain hose and drain the solution out of the hot tank and reservoir.
- i. Remove the drain hose and pour the container with 4L of ambient water into the reservoir until water reaches the level sensor to flush the descaling solution.
- j. Reconnect the drain hose and drain the rinse water into the bucket.
- k. Reassemble the product and turn the power and water back on.

Drain the system and use Hydrogen Peroxide to sanitize the system as outlined in the sanitization section.

Check all fittings for signs of scale or wear and replace as needed.

Check condition of the float mechanisms. Pay special attention to ensure no water has infiltrated the float balls.

Check solenoids for proper function. Dripping solenoids should be replaced immediately.

Every 5 years, in addition to the above, perform the following:

Replace all internal fittings and tubing

Replace solenoids.

SYSTEM INSPECTION

When changing filters or performing service, the following items should be completed:

- Visual Inspection
- Hose & Fitting Inspection
- Electrical Inspection
- Pressure and Flow Test
- Clean the exterior of system and condenser coils on rear of system.
- Temperature Check (Cold water should be below 50°F, Hot water should be above 160°F)
- TDS Check
- Hot Tank Switch On
- Site Cleanup

WARRANTY PROCEDURE

Procedure for S4 warranty evaluation:

Contact WELLSYS technical support and provide the following information:

- Serial number
- Failure
- Full details around failure
- Water pressure into the system
- Tap TDS
- TDS out of the cold and hot tanks
- Pictures

Depending on the situation, technical support may request more information. Upon approval, WELLSYS will process warranty credit or replacement part to be fulfilled

TROUBLESHOOTING INDEX

1. No water (Hot/Cold/Ambient)
2. Low or No CO2 Alert
3. Sparkling Gas Out (Weak Carbonation)
4. Filtration
5. Hot Water Dispense produces water that is not hot
6. Display is unlit, unit not operating

1. No water (Hot/Cold/Ambient)

Possible Cause	Solution
Check Water Feed and Valve	This unit will only dispense what you have available. If the water is turned off or is feeding the unit with slow flow, little to no water will dispense.
Check the Leak Stop	If water gets into the bottom of the system, then the leak stop will shut off the water supply. Drain any water from the leak stop using the plug on the back of the unit.
Supply Water Pressure	Check the water pressure into the unit, pressure should be max 50psi.

2. Low or No CO2 Alert

Possible Cause	Solution
CO2 Bottle is empty	If CO2 bottle is empty, replace with a fresh bottle of CO2 or have current bottle refilled.
CO2 Leak	CO2 Seal and Washer not added, add seal and nylon washer to connection between regulator and gas bottle valve. Check all CO2 connections for gas leaks. Replace connections or tubing as needed.
CO2 pressure not going to the unit.	Change CO2 Tank. Make sure tank valve is opened/on. Check CO2 hoses for kinks.



3. Sparkling Gas Out (Weak Carbonation)

Possible Cause	Solution
CO2 Pressure set too high.	Adjust CO2 pressure regulator below 4 bar, purge sparkling water, and reset the unit. (CO2 should be 1bar higher than water pressure to unit, and no more.)
No water flow to Carbonation Cannister	Dispense from Cold Feature to confirm water is present. Confirm water pressure to the back of unit is between 25-50psi.
Sparkling flow control set to high	Remove lid from unit. Check and adjust flow control on sparkling out line.

4. Filtration

We recommend using RO where possible and almost always if TDS from the tap is greater than 150 PPM. For an RO to work properly it is very important that the following variables are addressed and performed properly.

- Incoming Water Pressure: RO's require 60-70psi to work properly.
- Lower PSI will cause the reduction in TDS to suffer greatly, as well as the recovery rate.
 - 60psi results in (roughly) 7.3oz/min from 80GPD membrane
 - 40psi results in (roughly) 2-3oz/min from 80GPD membrane
 - 60psi results in (roughly) 98% reduction of TDS from the RO
 - 40psi results in (roughly) 80-85% reduction of TDS from the RO
 - Example:
 - 500 Tap TDS at 98% reduction = 10TDS product water
 - 500 Tap TDS at 85% reduction = 75TDS product water
 - 500 Tap TDS at 80% reduction = 100TDS product water
 - With the mineral add back filter a high concentration of calcium will negatively impact the amount of scale that will, as a result, negatively impact ice systems.
 - When using a bladder, this is much more susceptible to manifesting itself as a problem.
 - As the bladder pressure pushes back on the filter, lower pressure will reduce recovery even beyond the above stated levels and will be unable to properly fill the bladder.
 - This will also result in burning through pre filters as it will take much more water to make little product water.
 - Signs of this issue in gravity fed tanks will be manifested mostly through form of taste complaints, in this system it will manifest itself as running out of water prematurely.

Solutions for Low Water Pressure:

- Add a Booster Pump
- Use Carbon Filtration (be sure to remove the mineral add back filter)

Bladder Tanks:

- It is important that the right size bladder tank be used in conjunction with sufficient flow.
- It is ALSO important that the bladder tank be set to the correct pressure.

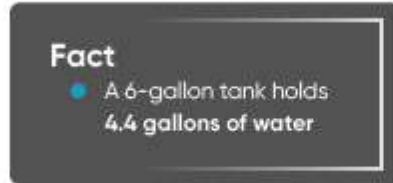

- Increasing air pressure will reduce the water capacity while also increasing water pressure
- Decreasing air pressure will increase the water capacity while also decreasing water pressure
- With no air the water tank will be full, but there will be no pressure to release water



Bladder Tank Water Pressure Changes

Bladder tanks have fluctuating water pressure as they empty. This may impact the flow rate going to the system as the tank is depleted.

- The amount of bladder tanks, filter banks feeding the bladder, pressure, and if a booster pump are needed must all be considered for install requirements. No two accounts are the same and usage will greatly impact the decision. If you have a large bladder tank installed and you have reports of no water, please revert to the above section on how to check to see if water flow is an issue.
- For large usage account with larger bladders, it may be necessary to have additional filter banks to improve the recovery time.
 - Please note that when doing this a booster pump may become necessary even if there a tap pressure of 60psi.
 - Failure to take this into consideration may cause the bladder to ineffectively fill due to pressure drop with multiple units in line which mainly manifests itself as the larger bladder tanks get closer to filling
 - This will also result in burning through pre filters and using a lot of water that will ultimately be just sent down the drain

Please see below for recommended air pressure that should be in the bladder depending on size of the bladder.

Size	Part Number	Size	Recommended Air Pressure
4 Gallon	EQGENE-0004	11" (Diam.) x 14" (Height)	6-7 psi
14 Gallon	EQGENE-0014	15" (Diam.) x 23" (Height)	6-7 psi
20 Gallon	EQGENE-0020	16" (Diam.) x 29" (Height)	7-10 psi
32 Gallon	EQGENE-0032	21" (Diam.) x 28" (Height)	7-10 psi
44 Gallon	EQGENE-0044	21" (Diam.) x 37" (Height)	10-15 psi
85 Gallon	EQGENE-0085	26" (Diam.) x 45" (Height)	10-15 psi
120 Gallons	EQGENE-0120	26" (Diam.) x 60" (Height)	10-15 psi

5. Hot Water Dispense produces water that is not hot

Possible Reason	Solution
Overload Thermostat Tripped	Locate the Overload Thermostat mounted on the side of the hot tank. Press the red button to manually reset the thermostat and return the hot tank power circuit to normal operation.
Hot Tank Power Switch is off	Locate the Hot Tank Power Switch on the back of the machine and switch it on. 

6. Display is unlit, unit not operating

Possible Reason	Solution
Power Cord Disconnected	Ensure the power cable is properly plugged into the wall power outlet.
Tripped GFCI	Reset GFCI outlet.