

WL500 – Sparkling

MANUAL



Waterlogic Commercial Products, LLC

3175 Bass Pro Drive

Grapevine, TX 76051

(800) 288-1891 www.waterlogicdealers.com

Tech Portal Website: techportal.waterlogic.com

WL500 MANUAL

Congratulations on your choice of the **Waterlogic WL500 Water Treatment System**. The **WL500 Water Treatment System** is a fully programmable self-contained model that dispenses cold, hot, extra-hot, and premium sparkling water. Every **WL500 Water Treatment System** includes:



High Performance Multi-Stage Filtration



Bio-Cote® Anti-Microbial Protection



Advanced In-Tank Ultraviolet (UV) Purification

The **Waterlogic WL500 Water Treatment System** provides exceptional quality and great tasting water with every use.

INTRODUCTION

Carefully read and follow all instructions to ensure proper and efficient operation of your **WL500 Water Treatment System**. Contact **Waterlogic** or an **Authorized Waterlogic Dealer** if you have any questions.

Waterlogic and **Authorized Waterlogic Dealers** employ trained service personnel who are experienced in the installation, function and repair of **Waterlogic** equipment. This publication is written for use by these qualified individuals. **Waterlogic** encourages users to learn about products, however, we believe that product knowledge and service is best obtained by consulting **Waterlogic** or an **Authorized Waterlogic Dealer**.

Waterlogic water treatment systems should be combined with selected water treatment components to create a system specifically tailored for each application by trained and qualified personnel.

Products manufactured and marketed by **Waterlogic** and its affiliates are protected by patents issued or pending in the United States and other countries.

Waterlogic reserves the right to change the specifications referred to in this literature at any time, without prior notice. Changes or modifications not expressly approved by **Waterlogic** could void the warranty and user's authority to operate the equipment.

TABLE OF CONTENTS

USER GUIDE

- Safety Alert Symbols.....4
- Safety Precautions.....4
- Features and Benefits.....6
- Certifications7
- Model Designations and General Specifications.....8
- Electrical and Shipping Specifications9
- Operating Instructions.....10
- Warranty11

SERVICE GUIDE

- Service Requirements.....12
- Bypassing Filters14
- **WL500** Principles of Operation15
- Premium Sparkling Overview18
- Hot Tank Principles of Operation19
- Resetting the Hot Tank Overload (High Limit Safety)20
- Hot Tank Descaling.....21
- Programming Menu and Instructions23
- PCB Wire Drawings.....37
- Replacement Components (Consumables).....38
- Drawings and Parts List.....39
- Base Cabinet Drawing and Assembly Instructions48
- Cup Holder Drawing and Assembly Instructions.....49
- Flow Diagram.....52
- Electrical Schematic.....53

INSTALLATION GUIDE

- Pre-Installation Procedures.....54
- Sanitizing Sparkling Tank Only59
- Draining Procedure.....61
- Quick Start Installation Instructions.....64
- Installation Instructions.....65

TROUBLESHOOTING GUIDE

- Fault Codes68
- Sparkling Water Troubleshooting74
- Electrical Supply Troubleshooting – Quick Guide76
- Dispense Troubleshooting.....81



SAFETY ALERT SYMBOLS

Read and follow all safety information carefully. The signal words used in this manual are selected as shown below and based on an assessment of the degree of potential injury or damage (severe or minor) and the occurrence of injury (definitely occurs or has the potential to occur) when the warning is ignored:

⚠ DANGER!

Indicates a situation which, when not avoided, results in death or severe injury.

⚠ WARNING!

Indicates a situation which, when not avoided, has the potential to result in death or severe injury; and/or severe property damage.

⚠ CAUTION!

Indicates a situation which, when not avoided, results or has the potential to result in minor injury; and/or minor property damage.

SAFETY PRECAUTIONS

Basic safety precautions should be followed, including the following:

Ensure all Local, State, and Federal Laws and Codes including health and safety guidelines are met when installing **Waterlogic** Equipment. Only qualified service technicians should attempt installation and service of **Waterlogic** Equipment. Always read the entire operating instructions before using the appliance and save these instructions for future use.

⚠ DANGER! *This product can cause death or severe injury if incorrectly operated, installed or maintained. The installation, maintenance, sanitizing and any repair must be performed by qualified persons trained by Waterlogic International or their approved distributors only. Do not remove any panel or cover to protect against electrical shock and exposure to UV radiation.*

⚠ DANGER! ELECTRICAL SHOCK HAZARD. *Always use a dedicated and properly grounded outlet. Unit should be protected by ground-fault circuit interrupter (GFCI) or residual current device (RCD) having a rated residual operating current not exceeding 30mA. Use only Waterlogic supplied power cord. Never use extension cords or power strips to connect unit. Do not use if the power supply cord is damaged. Always unplug from power supply prior to servicing.*

⚠ WARNING! AUTHORIZED USE ONLY. *This appliance is to be used for its intended purpose as described in this manual and untrained individuals who use this manual assume the risk of any resulting property damage or personal injury. This appliance can't be used by children and persons with reduced physical, sensory or mental capabilities or lack of experience.*

⚠ WARNING! UV-C EMITTER (UV LAMP). *This appliance contains a UV-C emitter (UV Lamp). UV-C radiation may, even in little doses, cause harm to the eyes and skin. Unintended use or damage to the housing may result in the escape of dangerous UV-C radiation. Never operate the UV-C emitter if damaged or removed from enclosure. Do not touch or look directly into the faucet.*

- ⚠ WARNING! DO NOT OPERATE IF DAMAGED.** *Unplug and isolate water supply if abnormal conditions exist. Contact Waterlogic or authorized dealer for repair, service, and installation to avoid hazards.*
- ⚠ WARNING! HOT WATER.** *Unit produces Hot Water in excess of 80°C (175°F). Water above 52°C (125°F) can cause severe burns or scalding. Keep unauthorized people and children away from the unit to avoid accidental dispensing of hot water.*
- ⚠ WARNING! CONNECT TO POTABLE WATER SUPPLY.** *This system is to be used for water only and is not intended for use where water is microbiologically unsafe or with water of unknown quality without adequate disinfection before or after the system.*
- ⚠ WARNING! TIP HAZARD.** *Dispenser could tip or fall causing serious injury. Always install unit on a firm, flat, and level surface and secure the **WL500 Water Treatment System** to the base cabinet with the screw provided to lock the components together. Secure unit to cabinet, wall, or floor if needed. Never place heavy items on top of unit and never climb, stand, or hang on unit or storage cabinet to prevent injury and damage.*
- ⚠ WARNING! UNIT IS HEAVY. TWO PERSON LIFT REQUIRED.** *Transport unit empty and always use material handling equipment or two people with proper lifting technique to reduce injury risk.*
- ⚠ WARNING! STORE AND TRANSPORT UNIT EMPTY. ALWAYS SANITIZE BEFORE USE.** *The unit must be completely drained before storing to avoid stagnation and reduce microbiological contamination (potential bacterial growth). Always sanitize before use to eliminate any potential microbiological contaminants.*
- ⚠ CAUTION! INDOOR USE ONLY.** *Never expose to direct sunlight, heat sources, or ambient air temperature above 37°C (100°F) or below 2°C (35°F). Install indoors and keep unit away from excessive humidity. Never expose to freezing temperatures. Ensure there is adequate clearance around the unit to allow refrigeration system condenser to dissipate heat. Warmer environments require more clearance around the unit. Minimum clearance around all surfaces of the machine is 2-inches. Installs where the ambient temperature exceeds 27°C (80°F), require a minimum of 4-inches clearance for proper heat dissipation and efficient operation.*
- ⚠ CAUTION! USE A WATER PRESSURE REGULATOR.** *Waterlogic will not be responsible for injury or damage caused by excessive water pressure. Input or feed pressure must be 40 psi to 60 psi. Be aware of any potential pressure surges caused by building/municipal pumping stations.*
- ⚠ CAUTION! USE UV STABILIZED SUPPLY LINES.** *Feed the unit with a potable ambient or cold water supply only. Feed water over 37°C (100°F) can damage the treatment components. Water block devices and external leak detectors are strongly recommended. Locate the unit as close to the water supply and the electrical connections as possible. Locate the unit as close to the water supply and the electrical connections as possible. Immediately isolate or close water supply valve and contact service representative if leak is noticed.*

Contact Waterlogic for assistance or help finding an Authorized Service Representative.

WL500 FEATURES AND BENEFITS



Premium Sparkling Water

Unlimited Premium Sparkling Water produced through innovative *Mizzling Technology*.

Cold, Hot, and Extra Hot Water

Pressure Fed Cold, Hot, and Extra Hot Selections to meet a wide range of customer demands.

High Volume Storage and Water Capacity

3 liters of Cold, 1 liter of Sparkling, and 1.6 liters of Hot Water Storage.

BioCote® Anti-Microbial Protection

Certain plastic, silicon and painted surfaces surrounding the dispensing areas and drip tray are infused with exclusive additive called BioCote®. BioCote® provides an effective barrier against microbes like bacteria and mold, which may cause odors and staining.



Large Dispense Area with Recessed Faucet

6-3/4 inch dispense height with BioCote® recessed faucet to protect from cross-contamination.

Drip Tray with Sensor and Alarm

Two-piece BioCote® drip tray for easy cleaning. Drip Tray Sensor and Drip Tray Full Fault Mode that halts supply to prevent overflow and sounds alarm to reduce accident potential.

Child Safeguard

WL500 Water Treatment System requires selection followed by main dispense and defaults back to cold/sparkling water selection after 3 seconds of inactivity to prevent accidental dispensing of hot water.

Digital Display

WL500 Water Treatment System has an innovative user interface utilizing a LCD display for easy use and programming.

Advanced Programming

Customizable settings for optimizing each **WL500 Water Treatment System** including; Cold Temp Set Point, Hot Temp Set Point, Static or Ranging Temperature Display, UV Timer, F/C Display, Multiple Languages, Filters Timer Setting, Filters Life Monitor, Energy Saving Sleep Mode, and Default Selection Mode.

Energy Saving Sleep Mode

Energy Saving Sleep Mode can be programmed to turn off heater after 3 hours of inactivity.

In-Tank UV Purification

Industry leading In-Tank UV Purification sterilizes water within Stainless Steel Cold Tank. UV Indicator and Fault Mode Protection to alert user and stop water supply.

Add-On Base Cabinet with Optional Cup Holder

Matching base cabinet with optional cup holder provides the flexibility to meet all installation requirements while minimizing inventory costs.



WL500 CERTIFICATIONS

Waterlogic Water Treatment Systems have been tested, and certified to rigorous NSF and UL Standards.

We believe that performance testing and certifications validate *Waterlogic* as a world-leader in water treatment systems.

WL500 Water Treatment System Certifications Include



Intertek

UL399 – Certified Drinking Water Cooler

Intertek Labs (ETL) Certified the *WL500 Water Treatment System* to ANSI/UL 399 Standard for Drinking Water Coolers.

CSA C22.2 No. 120 CSA Standard for Refrigeration.



BPA Free - *Waterlogic* tests for BPA and declares that all of its products are Bisphenol-A FREE and contain no harmful BPA plastics.

Safe Drinking Water Act

Waterlogic water treatment systems conform to the Safe Drinking Water Act (SWDA) “lead-free” amendment effective January 4, 2014, and *Waterlogic* has tested for BPA and declares that all of its products are Bisphenol-A FREE and contain no harmful BPA plastics.

Waterlogic is certified to ISO 9001:2015 – Quality Management Systems (certified by Intertek). ISO 9001 is the internationally accepted standard for well managed organizations that have adopted the key quality management principles to its operations to bring consistent quality products and a culture of continuous improvement.



MODEL/PART DESIGNATIONS

BRAND NAME	DESCRIPTION	MODEL – PART NUMBER
WL500	Waterlogic WL500 - Cold, Sparkling, Hot, Extra Hot	10-VMHCS3
	F-6004-M-HCS-DT-CS-INN	
	Serial Number Prefix: 93 or MB2H504CS	
AK-0005	Optional Base Cabinet	WLCP PN 10-7000
AK-0007	Optional Cup Dispenser for Base Cabinet	WLCP PN 10-7001

SPECIFICATIONS

<u>ITEM</u>	<u>WL500 (w/o BASE CABINET)</u>	<u>WL500 (with BASE CABINET)</u>
Water & CO ₂ Connection	¼" Quick Connect	
Cold Water Temperature	Cold Water Temperature – Factory Set Point 5°C (41°F) (Adjustable) 1.1° - 12.2°C (34° - 54° F)	
Cold Tank Size	2 Liter (.53 Gallons)	
Sparkling Tank Size	2 Liter (.53 Gallons) - 1 Liter pre-chill, 1 Liter sparkling	
Hot Water Temperature	Ho Water Temperature – Factory Set Point 87.2°C (189°F) Adjustable - 70° - 95°C (158°- 203°F) Programmable	
Hot Tank Size	1.6 Liter (4.3 Gallons)	
Recommended Incoming Feed Pressure	40-60 psi (275-414 kPa) – Use Pressure Regulator	
Maximum Working Pressure	60 psi (414 kPa) – Use Pressure Regulator	
Rated Service Flow Out	1.89 Liters per Minute (0.5 Gallons per Minute)	
CO ₂ Supply Requirement (400 Glasses of 12-ounce cups per one pound of CO ₂) ^	Food Grade CO ₂ - Regulated to 35-45 psi	
Environmental Temperature	2°- 37°C (35°- 100°F)	
Refrigerant Gas	R134a – 65 grams (2.29 ounces) - Hi (280 psi) Low (90 psi)	
R134a Pressures	High (230 psi), Low (90 psi)	

^400 16 oz. Cups of Premium Sparkling Water per pound of CO₂ under normal conditions. +G F I recommended - See Installation Instructions.

SHIPPING SPECIFICATIONS

<u>ITEM</u>	<u>WL500 (w/o BASE CABINET)</u>	<u>BASE CABINET ASSEMBLY P/N AK-0005</u>	<u>CUP HOLDER ASSEMBLY P/N AK-0007</u>
Width/Depth/Height #	43cm x 47.75cm x 47cm 17 in. x 18 in. x 18.5 in.#	43cm x 47.75cm x 125cm 17 in. x 18 in. x 49.25 in.	
Weight – Dry (w/o packaging)	29.5 kg (65 lb.)	14.5 kg. (32 lb.)	3.9 kg (8.5 lb.)
Shipping Information (length x width x height)	51cm x 47.75cm x 47cm 20 in. x 22 in. x 22 in. 8 units per pallet	84cm x 46cm x 25.4cm 33 in. x 18 in. x 10 in.	81cm x 30.5cm x 17.8cm 32 in. x 12 in. x 7 in.
Shipping Weight – Dry	70 lb. (32 kg)	35 lb. (16 kg)	4 kg (9 lb.)

#WL500 is 18.5 in. tall and may not fit between countertops and cabinets - Check installation to ensure adequate clearance.

ELECTRICAL SPECIFICATIONS

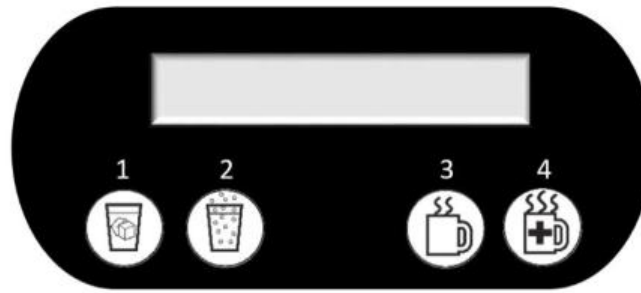

<u>ELECTRICAL SUPPLY</u>	<u>120V/60Hz</u>	<u>15 Amp Service⁺</u>
COMPONENT	POWER (approximate)	AMP DRAW (approximate)
Heater	500 Watts	4.2 Amps
Compressor	210 Watts	1.75 Amps
Fan Motor	18 Watts	0.15 Amps
UV Lamp System	8 Watts	0.07 Amps
Pump	26 Watts	0.22 Amps
WL500 TOTAL	762 Watts	6.39 Amps

OPERATING INSTRUCTIONS

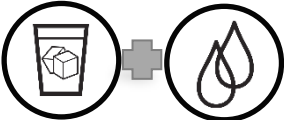
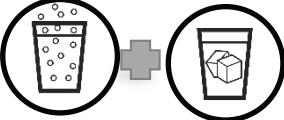

Main Dispense Button

The above picture shows front LCD display and control Panel for the **Waterlogic WL500 Water Treatment System**.

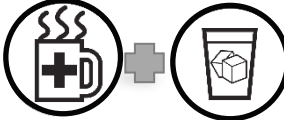
Buttons		Instructions
1		Press Cold Selection (Button 1), followed by the Main Dispense button
2		Press Sparkling Selection (Button 2), followed by the Main Dispense button
3		Press Hot Selection (Button 3), followed by the Main Dispense button
4		Press Extra Hot Selection (Button 4), Wait approximately 30 Seconds. Press Hot Selection (Button 3) * This procedure will raise the hot water temperature approximately 2° F. Repeating the process over again will raise the temperature about 2° F more until the desired temperature is reached up to a maximum limit of 203° F.

NOTE: Default selection mode is Cold Water. Selection will return to default after 3 seconds of inactivity. The default selection can be programmed to Cold or Sparkling. See Programming section of this manual.



WATERLOGIC MANUFACTURED WATER TREATMENT SYSTEM LIMITED WARRANTY **UNITED STATES AND CANADA ONLY**

Waterlogic water treatment systems are guaranteed to the original purchaser to be free of defects in materials and workmanship for a period of three (3) years from the date of purchase, but in no event longer than forty-eight (48) months from the date of manufacture. Waterlogic Commercial Products, LLC (“Waterlogic”) based in the U.S.A. and its affiliated companies are not liable for any cost of removal, installation, transportation, or any other charges which may arise in connection with a warranty claim.

This warranty does not cover damage or wear to products caused by abnormal operating conditions, accident, abuse, misuse, unauthorized or improper alteration or repair, damage caused by or resulting from shipping or accident, damage caused by hot water, freezing, flood, fire, or acts of God. The effects from chlorine corrosion, scaling and normal wear are specifically excluded from this warranty. This warranty does not cover products used outside the countries where the unit was purchased, and does not cover products that were not installed in accordance with Waterlogic printed installation and operating instructions obtained in training or from www.waterlogic.us. Failure to follow all instructions for operation and maintenance voids the warranty. This warranty is not transferable.

To obtain warranty repairs or replacement, you must obtain a Return Authorization from Waterlogic. To obtain a Return Authorization, you must submit a Return Authorization form with supporting documentation to Waterlogic for evaluation. The form is available at www.waterlogic.us. Supporting documentation must include, but is not limited to; proof of purchase, installation date, failure date, and supporting installation and maintenance data. After you submit a Return Authorization form and supporting documentation, Waterlogic will determine whether a reasonably apparent defect in materials or workmanship covered by this limited warranty exists. If Waterlogic determines the claimed defect is covered by this warranty, Waterlogic will, at its sole discretion, determine whether to correct the defect or replace the unit, free of charge to you. If Waterlogic determines that the unit should be returned for warranty service, Waterlogic will approve of return in writing and will issue a Return Authorization which you must obtain prior to shipping the product. You are responsible for the cost of freight in to Waterlogic.

Waterlogic and its affiliated companies hereby limit the duration of any and all implied warranties to a maximum period of three (3) years from the date of purchase including, but not limited to, the implied warranties of merchantability and fitness for a particular purpose. Some states do not allow limitations on how long an implied warranty lasts, so the above limitation may not apply to you. Consequential and incidental damages are not recoverable under this warranty. Some states do not allow the exclusion or limitation of incidental or consequential damages, so the above limitation or exclusion may not apply to you.

This warranty gives you specific legal rights and you may also have other rights which may vary from state to state.

New Warranty Policy issued by Waterlogic Commercial Products LLC, USA - January 10, 2014

Waterlogic Commercials Products LLC
3175 Bass Pro drive
Grapevine, TX 76051

Tel: (800) 288-1891
Website: waterlogic.us

SERVICE REQUIREMENTS

⚠ WARNING! *Read and understand the contents of this manual before attempting to service WL500 Water Treatment System. Failure to follow the instructions in this manual could result in death, serious personal injury, or severe property damage. Only trained and qualified technicians should attempt to install, maintain, or service Waterlogic Equipment.*

1. Visually inspect all electrical and water connections for signs of wear or damage.

⚠ DANGER! ***HIGH VOLTAGE ELECTRICAL HAZARD.** Unplug before inspection and service.*

2. **Waterlogic** recommends changing the UV Lamp every 12 months.

Note: UV Lamp Sensor is temperature sensitive. During extended periods of use, especially when filling or draining the unit, when water is not being dispensed, UV Lamp Sensor can overheat, initiating a UV Fault. If this occurs, turn off the unit for 5 minutes and allow sensor to cool before resuming operation.

⚠ WARNING! ***ULTRAVIOLET RADIATION.** Protect your skin and eyes against ultraviolet rays. Never look directly at an operating UV light. Disconnect before removing UV Lamp.*

⚠ CAUTION! ***UV LAMPS ARE HAZARDOUS.** Lamps are considered Hazardous Waste and must be disposed of accordingly. Refer to Product MSDS sheet for details.*

UV DECLARATION: The UV Lamp in this appliance conforms to the applicable provisions in the Code of Federal Regulations(CFR) requirements including; Title 21, Chapter 1, Subchapter J, Radiological Health.

3. Clean the Quartz Sleeve that surrounds the UV Lamp with a non-abrasive cloth, descaling solution, or ultrasonic bath if needed when changing UV Lamps.

⚠ CAUTION! ***UV SYSTEM IS FRAGILE.** Never handle the UV lamp or Quartz Sleeve with bare hands. UV Lamp and quartz sleeve must be free of oils and contaminants to ensure proper operation. Use a soft non-abrasive cloth to clean UV lamps.*

4. Inspect the Quartz Sleeve O-ring for wear or damage and replace as necessary.
5. Test UV Lamp and UV sensor (CDS) is working by removing the sensor from the Retaining Nut and covering the end to produce an audible alarm (continuous beep) and “UV Fault” on the display.
6. The Filters should be replaced every 6 months or 2,000 gallons, whichever comes first. Local water conditions will dictate your exact Filters requirements and service intervals. Flush 5 gallons of water through the Filters to rinse carbon fines. Do not rinse the Filters through the unit Solenoid Valve(s) and Tanks if at all possible to avoid contamination.
7. Reset Filters Life Timer if enabled. See programming instructions for details.

8. **WL500 Water Treatment System** Sparkling Tank has a Level Sensor Probe that needs to be maintained and descaled at every filter change.

⚠ WARNING! HIGH PRESSURE COMPRESSED GAS HAZARD. *Isolate CO₂ gas supply and relieve pressure in tank by opening PRV (pressure relief valve) before attempting to remove the Level Sensor Probe or any other component under pressure.*





9. Ensure there is adequate (minimum of 2") clearance around the unit and clean the condenser grill and Compressor fan to provide efficient cooling system operation.
10. Test the drip tray overflow function. Clean and dry off the drip tray and sensors.
11. Sanitize the Cold and Sparkling Tanks per instructions in the pre-installation procedures.

⚠ WARNING! SANITIZER MAY CONTAIN HAZARDOUS CHEMICALS. *Use of proper personal protective equipment such as rubber gloves and eye protection is required.*

12. Clean and sanitize external surfaces of the unit. Use soap and water or chemicals that are compatible with ABS plastic and will not damage or degrade the product surfaces.
13. Remove and clean the Faucet. Replace as needed.

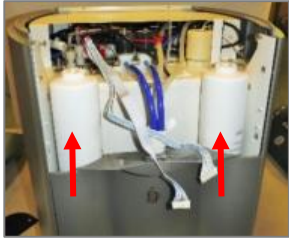
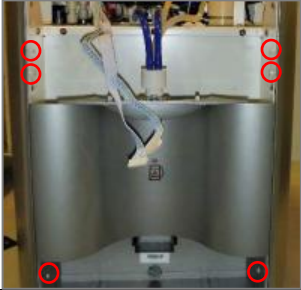
BYPASSING FILTERS

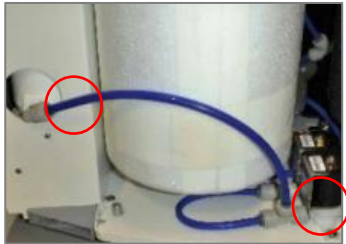
Older Models of the **WL500** Water Treatment System may have filters installed and need to be bypassed.

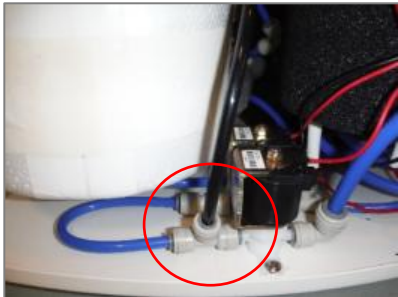
<p>1. Remove both reverse threaded filters in unit by unscrewing filters clockwise.</p> 	<p>2. Remove 6 Screws from Front of the WL500 Water Treatment System.</p> 
<p>3. Remove six screws from back of Unit.</p> 	<p>4. Remove both Side Panels</p>
<p>5. Remove Tube from Valve</p> <p>LEFT SIDE OF UNIT</p> 	<p>6. Remove Tube from Filter to Tee at Solenoid</p> <p>RIGHT SIDE OF UNIT</p> 
<p>7. Attach new tube from Water Inlet to Tee at Solenoid. Care to be taken to ensure that the new tube does not touch the compressor, nor any sharp edges.</p>  	

WL500 PRINCIPLES of OPERATION

It will take the **WL500 Water Treatment System** approximately 10 minutes to heat 1.6 liters of water in the hot circuit and 45 minutes to chill the 4 liters of water in the cold circuit to set point temperatures after all tanks have been properly filled. The **WL500 Water Treatment System** has two Cold Tanks; a 2 liter UV Cold Tank and a 2 liter Sparkling Cold Tank which is separated by a baffle/divider plate that isolates a 1 liter Sparkling Water Chamber from a 1-liter Pre-Chill Chamber within.

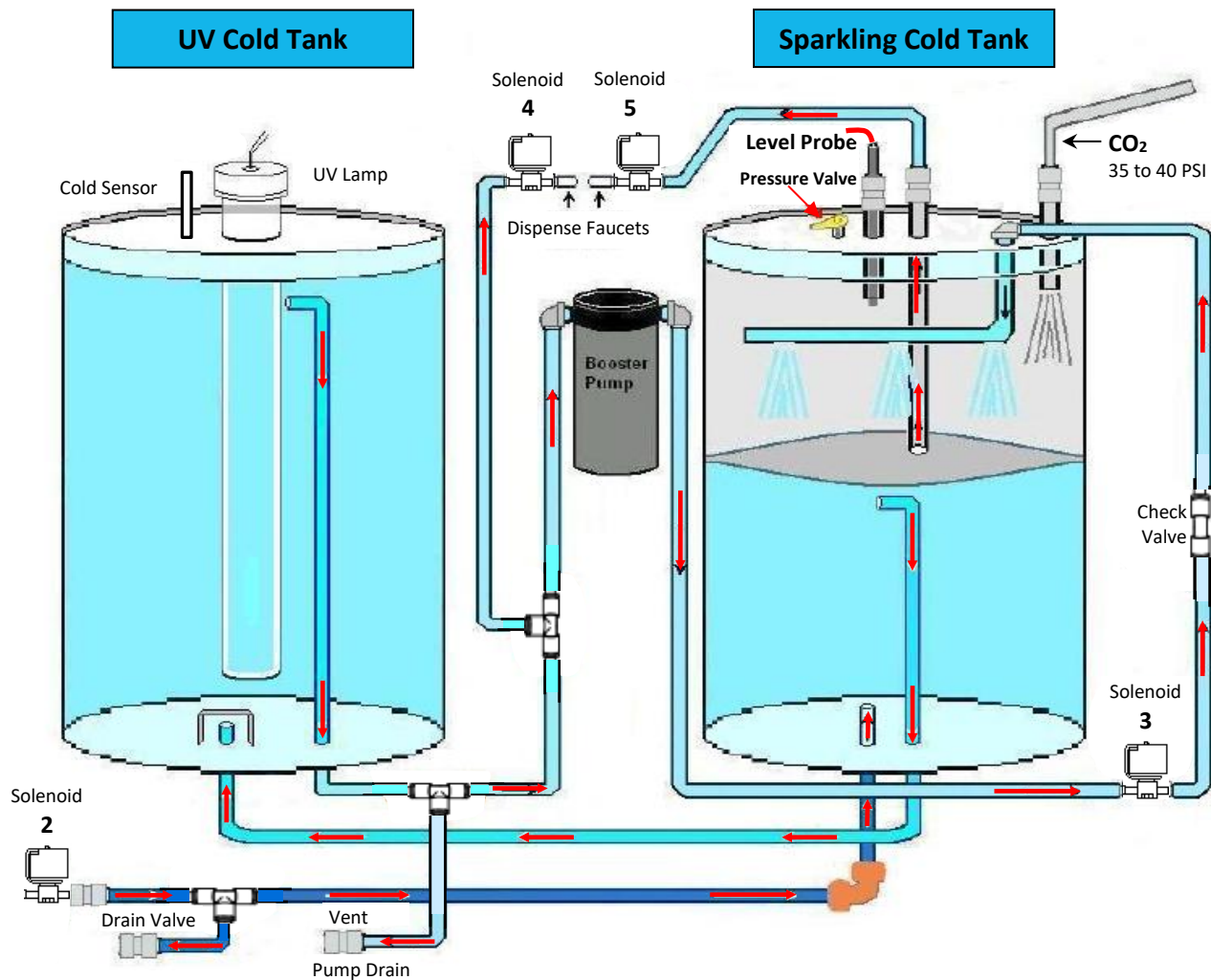

Dispensing Cold Still Water from the WL500 Water Treatment System

The **WL500 Water Treatment System** defaults to cold water selection when idle. “COLD” will appear on the display and cold water will be dispensed when the Main Dispense Button is pressed. Selecting COLD (Button 1) and then pressing the Main Dispense Button opens Solenoids 2 and 4, which allows supply water to push into the Pre-Chill Chamber of the Sparkling Cold Tank. Pressurize feed water pushes into the bottom of the pre-chill chamber and forces pre-chilled water through the tall draw tube into the bottom of the UV Cold Tank. UV treated, cold, still water is forced out through the tall draw tube, through Solenoid 4, out the faucet of the dispenser. When the main dispense button is released, both Solenoid 2 and 4 will close, thus stopping cold, still water output. The **WL500 Water Treatment System** is a pressure fed unit and output is dependent on supply.

Dispensing Hot Water from the WL500 Water Treatment System

To dispense hot water, select the small HOT (Button 3) and release. HOT will appear in the display, and press the Main Dispense Button. This will open the hot input solenoid (Solenoid 1— not shown above) and allow hot water to dispense through the faucet. The **WL500 Water Treatment System** can be programmed to default back to COLD or Sparkling after 3 seconds of inactivity as a safety feature to prevent accidental dispensing of hot water.

Dispensing Extra Hot Water from the WL500 Water Treatment System

Typically, the **WL500 Water Treatment System** hot water temperature is set to 87.2°C (189°F). In some cases, extra hot water is desired for making soups and teas. To temporarily raise the hot water temperature, users can depress and release the EXTRA HOT select button (button 4). The word HEATING will appear in the display for 10-seconds, which will raise the hot water temperature about 2°F. If the user presses the EXTRA HOT select button again after 30-seconds have expired, the word HEATING will appear in the display, and the temperature in the Hot Tank will be raised another 2° F. Eventually, as the process is repeated, the Hot Tank temperature will reach up to 95°C (203°F), and the extra heating will be disabled. At this point, 95°C (203°F) hot water can be dispensed from the **WL500, Water Treatment System** which is a desired temperature for soups/teas. The **WL500 Water Treatment System** will return to the hot temperature set point after the extra hot water is dispensed.

Dispensing Premium Sparkling Water from the WL500 Water Treatment System

To dispense sparkling water, press and release Sparkling (Button 2). SPARKLING will appear in the display. From this point, the user has 3-seconds to press the Main Dispensing Button for Premium Sparkling Water. The unit will default back to COLD water after 3 seconds unless the Default Set is changed to Sparkling. (See Programming Section)

When the Main Dispensing Button is pressed, Solenoid 5 will open, and the CO₂ gas supply from the bottle will push sparkling water out of the sparkling water chamber to the faucet. The CO₂ supply is what forces sparkling water out of the Sparkling Chamber. The sparkling water chamber is 1 liter in size and a maximum of 1 liter of sparkling water can be dispensed to the glass at a time. Once the Sparkling Tank empties of sparkling water, only CO₂ gas will dispense to the glass. At this point, the main dispensing button must be released to allow the **WL500 Water Treatment System** to make another batch of Premium Sparkling Water.

When the Main Dispensing Button is released, Solenoid 2 and 3 will open, and the Booster Pump will start the *Mizzling Process*. The Booster Pump will draw cold, still water from the Cold Tank, forcing that water through Solenoid 3 and the Check Valve into the Spray Header inside of the Sparkling Chamber. The spray will enter the Sparkling Chamber as a fine mist that will absorb the CO₂ gas that is present in the chamber. Once the Sparkling Tank fills with water, the Level Probe mounted in the top of the Sparkling Tank will detect the water and signal the PCB to shut down the Booster Pump, as well as close Solenoid 2 and 3. Note that the Booster Pump can supply this spray up to approximately 70 psi, if the CO₂ gas pressure is too high, the Booster Pump will not be able to overcome the gas pressure, and will “dead-head”. If the booster pump runs for 10 minutes without a signal from the level sensor, the PCB will shut down the sparkling water process and signal a NO WATER SUPPLY FAULT will be displayed.

Once the level sensor detects the tank is full of water, the PCB will shut down sparkling water generation (*Mizzling Process*). The **WL500 Water Treatment System** will return to the COLD default selection after 3 seconds. Cold and Hot water can be dispensed while sparkling water is being generated. The sparkling water generation will stop as soon as sparkling water is dispensed or the chamber fills. The **WL500 Water Treatment System** will make 1 liter (34 ounces) of sparkling water in approximately 1 minute, 20 seconds. Typically, users will only dispense up to ½ liter (17 ounces) of sparkling water at a time, and the **WL500 Water Treatment System** takes about 40 seconds to regenerate sparkling water tank accordingly.



Waterlogic WL500 Water Treatment System produces Premium Sparkling Water which is made in a batch and contains a fine, dense carbonation as compared to some “soda water” products. Optimal sparkling water is generated with cold water under 7.8°C (46°F).

WL500 Water Treatment System Sparkling Level Sensor Probe requires inspection and service. See Service Section.

[WL500 Water Treatment System Energy Saving Sleep Mode](#)

The **WL500 Water Treatment System** has programmable Energy Saving Sleep Mode. When Energy Saving Sleep Mode is ON the **WL500 Water Treatment System** will shut down the heater circuit to conserve energy after the machine is idle for 3 hours. The heater circuit will awake once any button is depressed and it will reheat the Hot Tank to set point temperature. “ENERGY SAVING SLEEP MODE” will be displayed. Always check the Energy Saving Sleep Mode setting if unit does not produce hot water as expected.

[WL500 UV Protection](#)

The **Waterlogic WL500 Water Treatment System** contains a germicidal ultraviolet (UV) lamp that sterilizes water in the Cold Tank and requires annual replacement.

The **WL500 Water Treatment System** has a UV CDS Sensor located in the Cap of the UV Tank. UV Fault Mode Protection will alert the user with a 20 second audible alarm and display UV FAULT on screen when UV light is not detected. UV Fault Mode Protection will shut off Cold and Sparkling water to avoid potentially dispensing unsafe water.

WATERLOGIC WL500 PREMIUM SPARKLING OVERVIEW

Waterlogic WL500 Water Treatment System produces Premium Sparkling Water which is made in a batch and contains a fine, dense carbonation as compared to other “soda water” products in the market. Optimum sparkling water is generated in the **WL500 Water Treatment System** with 5°C (41°F) cold water and food grade CO₂ at 43.5 psi (3 Bar).

Please ensure customer’s carbonation expectations are clear before installing a **WL500 Water Treatment System**. Waterlogic Premium Sparkling Water is very similar to Perrier and Pellegrino.

The premium fine dense sparkling water produced by the **WL500 Water Treatment System** may not meet user's expectations if they are looking for large bubble soda stream type of carbonation.

A blind taste test using Pellegrino/Perrier is a great way to demonstrate the expectations and quality of the Waterlogic Premium Sparkling Water. Open two bottles and empty one and fill with Premium Waterlogic Sparkling Water from a freshly regenerated tank operating at optimum conditions (41°F / 43 psi). Recap both and mark the bottles accordingly. Ensure the bottles are sampled at the same temperature by refrigerating if necessary for later use and comparison. Most users will prefer the great taste of the Waterlogic Premium Sparkling Water at a fraction of the cost of the bottled counterparts.

You may purchase a carbonation tester from a company such as Taprite to measure the level of carbonation if you wish to quantify the results and check the output of the **WL500 Water Treatment System**. The level of carbonation is very consistent as long the test conditions are repeatable and proper testing procedures are followed.

Temperature of the water in the **WL500 Water Treatment System** has the largest impact on the taste and carbonation levels and the Cold Tank must be below 46°F (prefer 41°F) before injecting water into the Sparkling Chamber (carbonator) to produce proper results.

The temperature inside the Cold Tank can be displayed on the LCD screen by setting the temp display function to "Ranging" mode. See the programming section to adjust this setting.



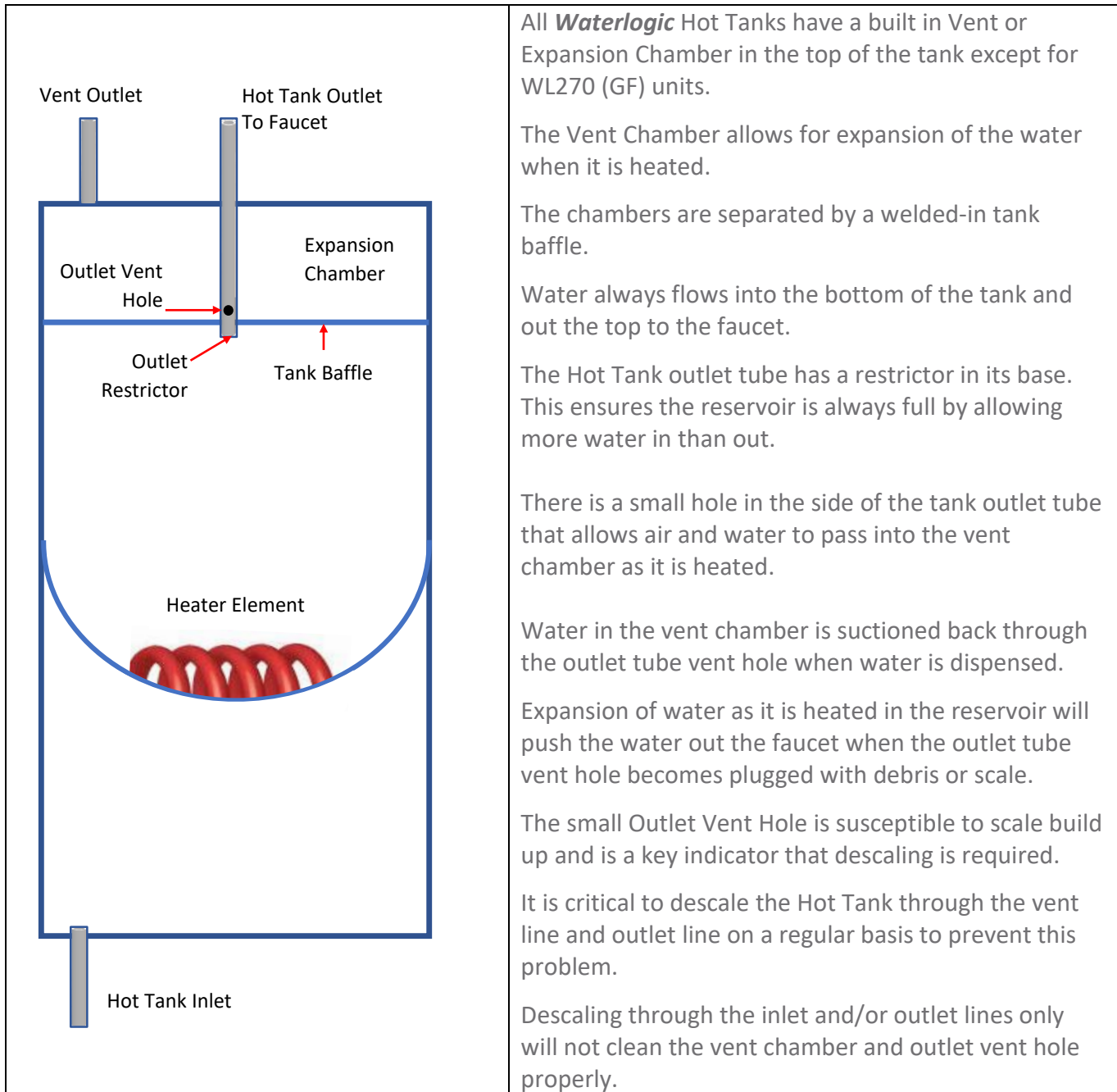

Allow a minimum of an hour for the **WL500 Water Treatment System** to chill the cold circuit to the 41°F set point temperature before sampling the sparkling water. Once the water is chilled, the Sparkling Tank should be "Regenerated" by completely and continuously dispensing the initial batch (0.8 liters) of product from the carbonator until only Co₂ gas is dispensing from the faucet. The initial batch of sparkling product will be flat because it was injected into the carbonator at ambient temperature when initiating the **WL500 Water Treatment System**. Always remember that the water must be below 46° F to make premium sparkling water.

Do not set the cold temperature set point below 41°F or you increase the risk of freezing the Sparkling Tank. The Thermistor that controls the refrigeration system is located in the well in the UV Cold Tank and does not monitor water temperature in the Sparkling Tank (carbonator). The refrigeration system chills both tanks simultaneously and is either on/off based up on feedback from the Thermistor. Frequent or continuous use of the cold still water results in refrigeration system running and continuously chilling the sparkling product in the carbonator below freezing point. This can result in a frozen Sparkling Tank and sparkling product will not be dispensed even with proper gas supply.

HOT TANK PRINCIPLES OF OPERATION



RESETTING THE HOT TANK OVERLOAD OR HIGH LIMIT SAFETY

1.	Green Compressor/Heater Switch must be in the <i>O=OFF</i> position	
2.	Unplug the Power Cord from rear of WL500 Water Treatment System .	
3.	Remove the Side Panel by removing the Front Hatch and Side Panels.	
4.	Locate the Hot Tank	
5.	Press the Reset Button	
6.	Replace the Lower Front Panel.	
7.	Plug in the Power Cord.	
8.	Turn on the Green Compressor / Heater Switch <i>I=ON</i> position The Hot and Cold Tanks must be filled with water BEFORE turning on the Red Heater and Compressor Switch.	
9.	Verify the cooler is fully operational before installing it at the customers' site.	

DESCALING THE HOT TANK

The Hot Tank requires removal of mineral deposits (descaling) on a regular basis, depending upon filtration and local water conditions. Descaling is an important process that removes calcium deposits, or scale, that can build up inside a tank over time. Calcium and scale is non-toxic but left unattended, it will hinder your unit's performance.

Hot Tank Troubleshooting: Hot water intermittently forced out through the faucet is an indicator that descaling is needed. This occurs when scale has deposited on the expansion slot inside the Hot Tank vent chamber and blocks the normal path for water to expand.

Descaling should take place every 6 to 12 months to preserve the long-term health of your unit. Use non-toxic cleaner such as ScaleKleen, DEZCAL, 20% Citric Acid Solution, or Undiluted Vinegar Solution to remove mineral deposits as directed by the manufacturer.

⚠ WARNING! PERSONAL PROTECTIVE EQUIPMENT REQUIRED. *Always ensure proper ventilation and use rubber or nitrile gloves and eye protection when using chemicals. Refer to Material Safety Data Sheet for specific requirements of each product.*

⚠ CAUTION! STAINLESS STEEL TANK DESCALING.

The Hot Tank is made from stainless steel. Ensure descaling solution is compatible with stainless and always flush the unit completely. Dispose in an environmentally safe manner.

See Hot Tank Descaling Video and training procedure located on the **Partner Area of the Waterlogic Website** for more detailed instructions. www.waterlogic.us

Materials Needed:

- Personal Protective Equipment. Rubber or Nitrile Safety Gloves and Protective Eyewear
 - Phillips Screwdriver
 - Temperature Gauge
 - Water Pitcher or Container to collect water from the faucet
 - 5-gallon container or drain basin
 - Citric Acid Based Cleaner
 - ¼" Plastic Tubing, at least 4 feet in length, and assorted ¼" quick connect fittings
 - Sanitizing Cartridge
 - Food Coloring
1. Put descaler per directions and 3 drops of food coloring into the descaling cartridge.
 2. Connect descaling cartridge to the inlet water supply and connect to inlet bulkhead fitting on the back of the unit. Turn on Water Supply.
 3. Select Hot Water and depress the Main Dispensing Button on the Front Control Panel until descaling solution (colored water) comes out of the faucet. Container and drain basic will be required to catch water from the faucet.

4. Turn off water supply and remove sanitizing cartridge from inlet water supply. Reconnect water supply to inlet fitting.
5. Allow descaling solution to remain in the Hot Tank for 15 minutes (length of time may vary depending on water conditions).
6. Place a pitcher, catch basin or other container under the faucet of the **WL500 Water Treatment System**.
7. Flush the Hot Tank until water runs clear.
8. Once clear Water dispenses from the faucet the Hot Tank has been descaled.

 **WARNING! HOT WATER HAZARD.** *Unit Produces Very Hot Water and Steam. Always use insulated and chemically compatible containers and let unit cool down before draining the Hot Tank to avoid injury.*

 **CAUTION! REPLACE HOT TANK (HT-3021) EVERY 3-5 YEARS.** *The Hot Tank and its controls should be replaced a minimum of every five years to ensure efficient operation.*

9. Always ensure unit is performing to the customer's satisfaction.





 **CAUTION! RIBBON CONNECTORS MUST BE FULLY ENGAGED.** *Ensure ribbon connectors are properly engaged and fully seated in front PCB (Printed Circuit Board) to avoid intermittent/connectivity issues any time the front Hatch Panel is accessed.*

 **WARNING! REINSTALL ALL PANELS AND COVERS.** *Always reinstall all Panels, Protective Covers, and fasteners after servicing equipment. Failure to do so could result in severe personal injury and will void the certifications and warranty of the equipment.*

PROGRAMING MENU AND SELECTIONS

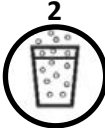
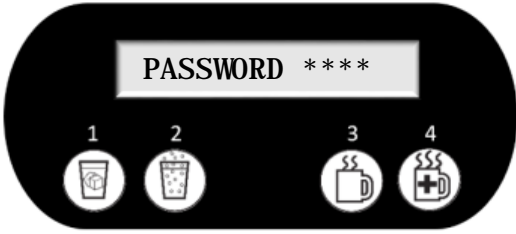
Menu	Options	Brief Description
Cold Temp Set	3° - 12°C	The cold temperature can be set between 3°C and 12°C or 37°F and 54°F, depending on which units are selected (°C or °F) in the F/C option.
	37° - 54°F	Recommended/Default Setting is 5°C/41°F.
Hot Temp Set	70°C - 95°C	The hot temperature can be set between 70°C and 95°C or 158°F and 203°F, depending on which units are selected (°C or °F) in the F/C option.
	158°F - 203°F	Recommended/Default Setting is 87°C/189°F.
Temp Display	Static	The display indicates the STATIC (SET POINT) temperature. Default
	Ranging	The display indicates the ACTUAL tank temperature
UV Timer	3 minutes	The UV Lamp lights every time you take a drink of cold water, and stays on for 3 minutes. Recommended/Default Setting is 3 minutes
	10 minutes	The UV Lamp lights every time you take a drink of cold water, and stays on for 10 minutes.
	Constant	The UV Lamp stays on when power is on. Not Recommended
F/C	°F	Temperatures are displayed in degrees Fahrenheit. Default is °F
	°C	Temperatures are displayed in degrees Celsius.
Language	English	The display will read in English. Default is English
	Spanish	The display will read in Spanish
	French, Etc.	The display will read in French, and many others...
Flow Counter	Liters (4000-9000)	DO NOT USE. "NO WATER SUPPLY" Fault will occur. Use Filters Timer Instead.
	Gallons (1000-3000)	DO NOT USE. "NO WATER SUPPLY" Fault will occur. Use Filters Timer Instead.
Filters Timer	3 months	Timer for Filters Life set at 3 months. Displays "Change Filters" after 3 months
	6 months	Timer for Filters Life set at 6 months. Displays "Change Filters" after 6 months
	9 months	Timer for Filters Life set at 9 months. Displays "Change Filters" after 9 months
	None	Timer for Filters Life is turned off. Default is None
Filters Life	00 DAYS	Indicates amount of water flowed(gal/liters) or days elapsed since last reset Ensure Filters Timer is enabled and Filters Life indicates DAYS
Energy Saving Sleep Mode	On	Shuts heater down (hot water) if not used in 3 hours. – Default Sleep is ON
	Off	Hot water remains powered indefinitely.
Default Set	Cold	Defaults Display & Dispense Selection to Cold after 3 seconds. Default is Cold
	Sparkling	Defaults Display & Dispense Selection to Sparkling after 3 seconds.
Reset	OK?	Resets the Filters Life to zero. Confirm by selecting Button 3 (Hot) to Save and Exit. This resets the timer.

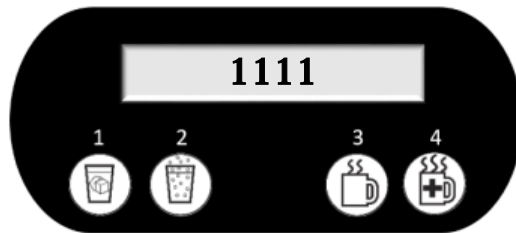
PROGRAMING - ACCESSING PROGRAMMING MODE

<p>1.  + </p>	<p>Press Buttons No. 1 and No. 2 <u>at the same time for seven seconds</u> until "Password ****" appear on the display.</p> 
<p>2.  </p>	<p><u>Enter Password:</u></p> <p>Alternately Press No. 1 and No. 2 to enter the password</p> <p><u>Password is: 1111</u></p> <p>*Press Cold Selection Button (No. 1) to enter the password number *Press Sparkling Selection Button (No. 2) to move to the next password number</p> 
<p>3. </p>	<p>Press Hot Selection Button (No. 3) to enter the "1111" Password</p>
<p>After entering the programming mode – Press:</p> <p>4. Cold Selection Button (No. 1) to scroll programming options forward</p> <p>Sparkling Selection Button (No. 2) to scroll programming options backwards</p>	

PROGRAMING – COLD TEMPERATURE SETTING

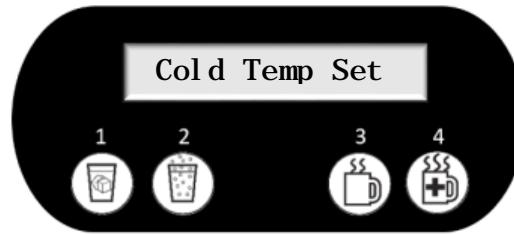

The cold temperature can be set between 3°C and 12°C (37°F and 54°F) depending on which units are selected (°C or °F) in the F/C programming setting.

Recommended / Default Temperature Setting: 5°C (41°F)

1. Enter the Programming Mode in “Accessing Programming Mode” instructions.

2.  After entering the programming mode – Press Cold Selection Button (No. 1) until “Cold Temp” is displayed.

**Note:*

*Pressing Cold Selection Button (No. 1) scrolls programming options forward
Pressing Sparkling Selection Button (No. 2) programming options backward*

3.  Press Hot Selection Button (No. 3) to see what the current setting is.

4.  Press Cold Selection Button (No. 1) to increase the Cold Temperature Setting

4.  Press Sparkling Selection Button (No. 2) to decrease the Cold Temperature Setting.

Recommended / Default Temperature Setting: 5°C (41°F)

5.  Press Hot Selection Button (No. 3) to save the temperature setting chosen.

6.  Press Extra Hot Selection Button (No. 4) to exit programming mode.

PROGRAMING – HOT TEMPERATURE SETTING

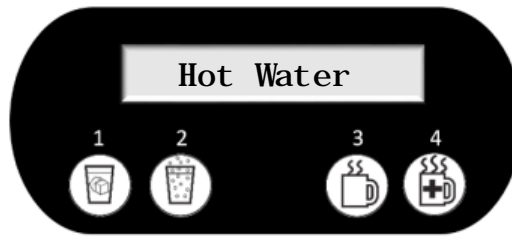

The hot temperature can be set between 70°C to 95°C (158°F to 203°F) depending on which units are selected (°C or °F) in the F/C programming setting.

Recommended / Default Temperature Setting: 87°C (189°F)

1. Enter the Programming Mode in “Accessing Programming Mode” instructions.

2.  After entering the programming mode – Press Cold Selection Button (No. 1) until “Hot Water” is displayed.

**Note:*

*Pressing Cold Selection Button (No. 1) scrolls programming options forward
Pressing Sparkling Selection Button (No. 2) programming options backward*

3.  Press Hot Selection Button (No. 3) to see what the current setting is.

4.  Press Sparkling Selection Button (No. 2) to increase or decrease the temperature setting.





Recommended / Default Temperature Setting: 87°C (189°F)

5.  Press Hot Selection Button (No. 3) to save the temperature setting chosen.

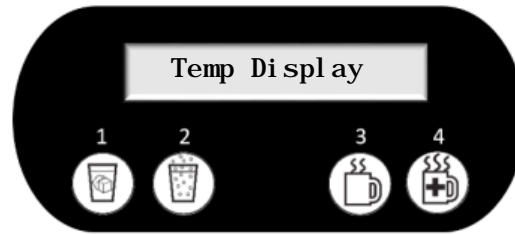
6.  Press Extra Hot Selection Button (No. 4) to exit programming mode.

PROGRAMING – TEMPERATURE DISPLAY



<p>Temperature display is the temperature that the display screen shows.</p> <p>Static – Display will always show the STATIC (SET POINT) temperature – Recommended / Default</p> <p>Ranging – The Display will show the temperature of the water in the tank.</p>	
1.	Enter the Programming Mode in “Accessing Programming Mode” instructions.
2.	<p>3</p>  <p>Press Hot Selection Button (No. 3) to see what the current setting is.</p>
3.	<p>2</p>  <p>Press Sparkling Selection Button (No. 2) to select “Static” or “Ranging”</p> <p>Recommended / Default Setting is STATIC</p>
4.	<p>3</p>  <p>Press Hot Selection Button (No. 3) to save the setting chosen.</p>
5.	<p>4</p>  <p>Press Extra Hot Selection Button (No. 4) to exit programming mode.</p>

PROGRAMING – UV TIMER SETTING

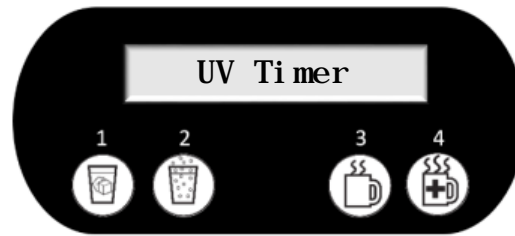

Determines how long the UV Lamp stays on.

3 minutes – The UV Lamp comes on every time you take a glass of cold water, and stays on for 3 minutes. **Recommended / Default**

10 minutes – The UV Lamp comes on every time you take a glass of cold water, and stays on for 10 minutes.

Constant - The UV Lamp is set to be on all the time. **Not Recommended**

1. Enter the Programming Mode in “Accessing Programming Mode” instructions.

2.  Press Hot Selection Button (No. 3) to see what the current setting is.

3.  Press Sparkling Selection Button (No. 2) to select “3 minutes”, “10 minutes” or “constant”.
Recommended / Default Setting is 3 Minutes

4.  Press Hot Selection Button (No. 3) to save the setting chosen.

5.  Press Extra Hot Selection Button (No. 4) to exit programming mode.

PROGRAMING – TEMPERATURE DISPLAY SETTING

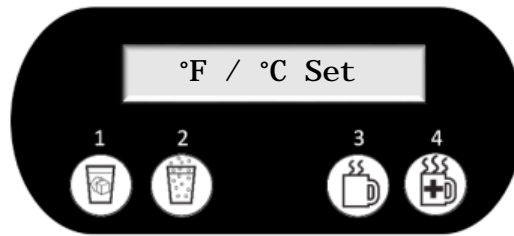



Determines how the Display shows all temperature settings options:

°F- Fahrenheit – DEFAULT SETTING

°C - Celsius

1. Enter the Programming Mode in “Accessing Programming Mode” instructions.

2.  Press Hot Selection Button (No. 3) to see what the current setting is.

3.  Press Sparkling Selection Button (No. 2) to select “Fahrenheit” or “Celcius”
Recommended / Default Setting is Fahrenheit

4.  Press Hot Selection Button (No. 3) to save the setting chosen.

5.  Press Extra Hot Selection Button (No. 4) to exit programming mode.

PROGRAMING – LANGUAGE DISPLAY SETTING

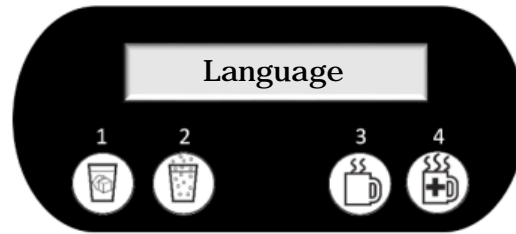

The language shown on the display options:

English – Default

French

German

Spanish

*Many other languages.

1. Enter the Programming Mode in “Accessing Programming Mode” instructions.

2.  Press Hot Selection Button (No. 3) to see what the current setting is.

3.  Press Sparkling Selection Button (No. 2) to select “Fahrenheit” or “Celcius”
Recommended / Default Setting is Fahrenheit

4.  Press Hot Selection Button (No. 3) to save the setting chosen.

5.  Press Extra Hot Selection Button (No. 4) to exit programming mode.

PROGRAMING – FLOW COUNTER

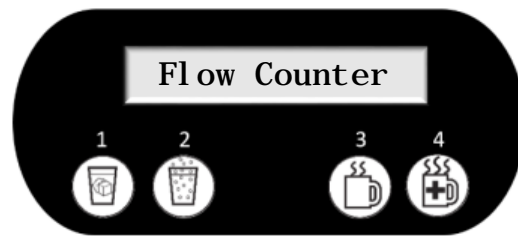

Flow Counter

Do not use this setting – it will result in a “NO WATER SUPPLY” fault.

Use the Filters Timer instead.



PROGRAMING – FILTER TIMER

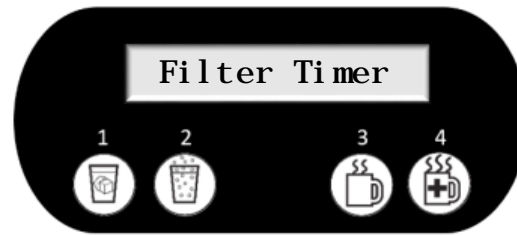

Timer for Filters Life:

NONE – Timer for Filters turned off – Default Setting

3 months – Displays “Change Filters” after 3 months

6 months – Displays “Change Filters” after 6 months

9 months – Displays “Change Filters” after 9 months

1. Enter the Programming Mode in “Accessing Programming Mode” instructions.

2.  Press Hot Selection Button (No. 3) to see what the current setting is.

3.  Press Sparkling Selection Button (No. 2) to select “None, 3 months, 6 months or 9 months)
Recommended / Default Setting is NONE

4.  Press Hot Selection Button (No. 3) to save the setting chosen.

5.  Press Extra Hot Selection Button (No. 4) to exit programming mode.

PROGRAMING – FILTER LIFE

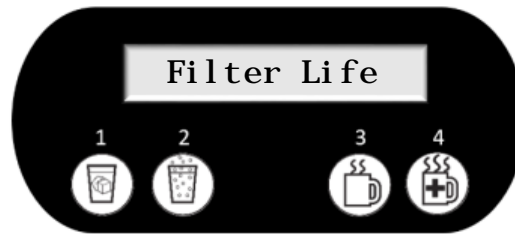

Filter Life indicates the amount of water that has flowed (gallons / liters) or days elapsed since last reset.

Ensure Filter Timer is enabled, and Filters Life indicates DAYS.

1. Enter the Programming Mode in “Accessing Programming Mode” instructions.

2.  Press Hot Selection Button (No. 3) to see what the current setting is.

3.  Press Sparkling Selection Button (No. 2) to select “00 DAYS”

4.  Press Hot Selection Button (No. 3) to save the setting chosen.

5.  Press Extra Hot Selection Button (No. 4) to exit programming mode.

PROGRAMING – ENERGY SAVING SLEEP MODE

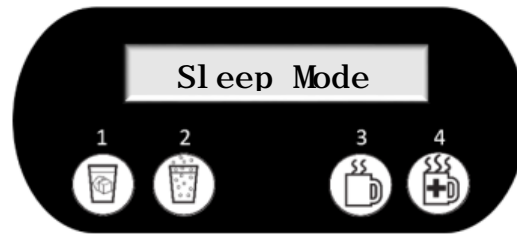



Energy Saving Sleep Mode

On – Energy Saving Sleep Mode on. Shuts hear down (hot water) if not used in 3 hours. Default Setting

Off - Hot water remains powered indefinitely.

1. Enter the Programming Mode in “Accessing Programming Mode” instructions.

2.  Press Hot Selection Button (No. 3) to see what the current setting is.





3.  Press Sparkling Selection Button (No. 2) to select “On” or “Off”
Recommended / Default Setting is On

4.  Press Hot Selection Button (No. 3) to save the setting chosen.

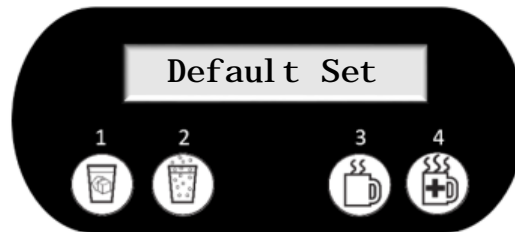
5.  Press Extra Hot Selection Button (No. 4) to exit programming mode.



PROGRAMING DEFAULT DISPLAY AND DISPENSE PROGRAMMING

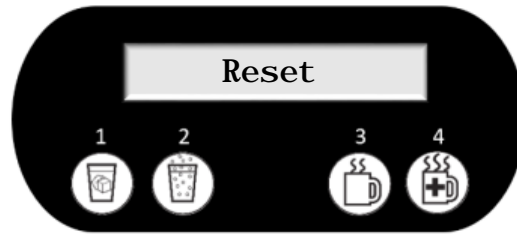

Defaults Display and Dispense Selection after 3 seconds	
Cold - Default	
Sparkling	
1.	Enter the Programming Mode in “Accessing Programming Mode” instructions.
2.	<div style="display: flex; align-items: center;"> <div style="text-align: center; margin-right: 10px;"> 3  </div> <div>Press Hot Selection Button (No. 3) to see what the current setting is.</div> </div>
3.	<div style="display: flex; align-items: center;"> <div style="text-align: center; margin-right: 10px;"> 2  </div> <div>Press Sparkling Selection Button (No. 2) to select “On” or “Off”</div> </div> <p style="text-align: center;">Recommended / Default Setting is On</p>
4.	<div style="display: flex; align-items: center;"> <div style="text-align: center; margin-right: 10px;"> 3  </div> <div>Press Hot Selection Button (No. 3) to save the setting chosen.</div> </div>
5.	<div style="display: flex; align-items: center;"> <div style="text-align: center; margin-right: 10px;"> 4  </div> <div>Press Extra Hot Selection Button (No. 4) to exit programming mode.</div> </div>

PROGRAMING – RESET FILTERS LIFE TO ZERO



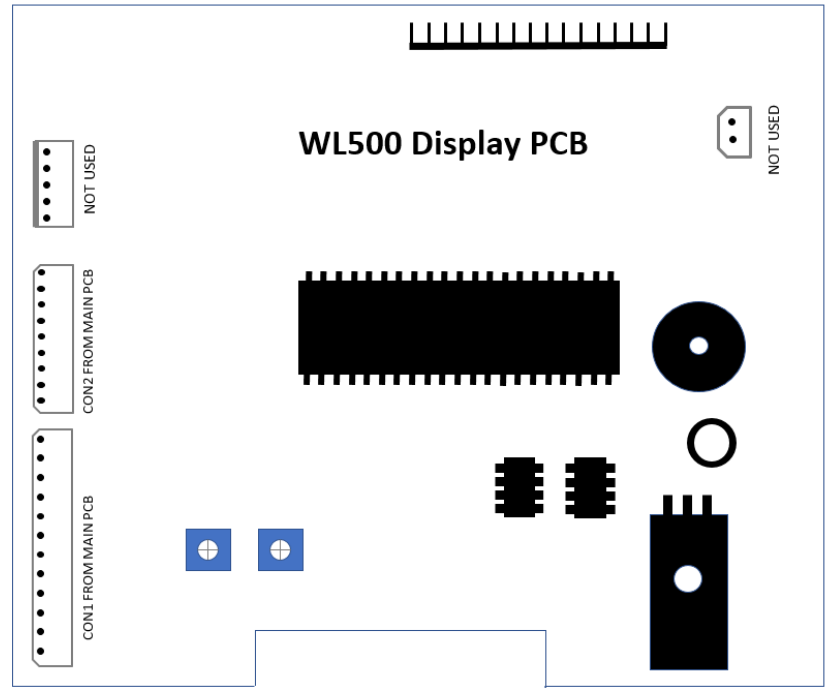
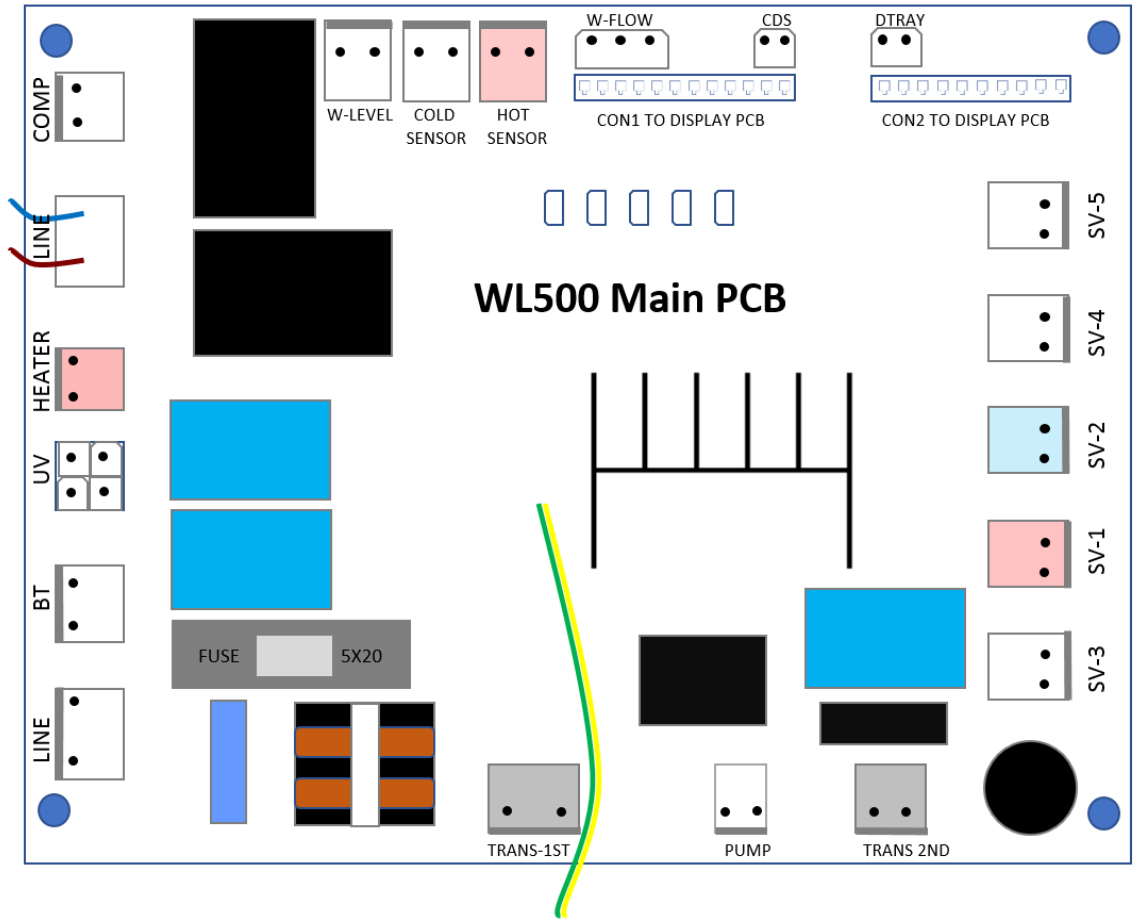

Reset	
Resets the Filters life to zero.	
1.	Enter the Programming Mode in “Accessing Programming Mode” instructions.
2.	<div style="display: flex; align-items: center;"> <div style="text-align: center; margin-right: 10px;"> 2  </div> <div>Press Sparkling Selection Button (No. 2) to select “OK?”</div> </div>
3.	<div style="display: flex; align-items: center;"> <div style="text-align: center; margin-right: 10px;"> 3  </div> <div>Press Hot Selection Button (No. 3) to save the setting chosen.</div> </div>
4.	<div style="display: flex; align-items: center;"> <div style="text-align: center; margin-right: 10px;"> 4  </div> <div>Press Extra Hot Selection Button (No. 4) to exit programming mode.</div> </div>

PCB WIRE DRAWINGS



REPLACEMENT COMPONENTS (CONSUMABLES)

Component	WLCP PN	Frequency of Replacement
8W UV Lamp Assembly	10-7020	Every 12 months, or as required Factory PN CT-2045
Sparkling Chamber Level Sensor Probe Assembly	10-7250	To be maintained and descaled at every filter change. Replace if needed. Factory PN CT-2023 
Hot Tank (with controls) 1.6L Factory Set Point 85°C (185°F)	10-7082	Every three to 3-5 years depending on usage. Descaling hot tank may be required on a regular basis depending on filtration. Factory PN HT-3021
CO ₂ Pressure Regulator with tamper proof adjuster, preset to 35-45 psi, single output pressure gauge, inline shut-off valve, ¼ quick connect fitting, safety relief, and CO ₂ CGA-320 thread adapter.	AK-0003-L00	Needed to ensure input water pressure is adequate for machine performance. 

⚠ CAUTION! Use only Waterlogic Replacement parts that can be obtained from *Waterlogic* or an *Authorized Waterlogic Dealer*, failure to do so will void the Warranty.

See Installation and Service Manual for additional information.

Hot Tank Service

Hot Tanks (with controls) must be replaced at least every 3-5 years depending on usage. Descaling hot tank may be required on a regular basis depending upon filtration and local water conditions. See Installation and Service Manual for further details.

Surface Cleaning

Clean on a regular basis with damp lint free cloth. Never use harsh chemicals (alcohol or acid based) or abrasive agents on any part of the product to avoid damage. A mild cleaner such as Simple Green or equivalent is recommended.

DISPOSAL

End of Life

At the **end of this product's life**, ensure that it is disposed of in an environmentally friendly manner which is fully compliant **with all Federal/State/Local Requirements and Guidelines**. Do not dispose of this appliance with normal household or business waste.

WL500 DRAWINGS and PARTS LIST

Yellow = Consumables
 Green = Recommended spare parts

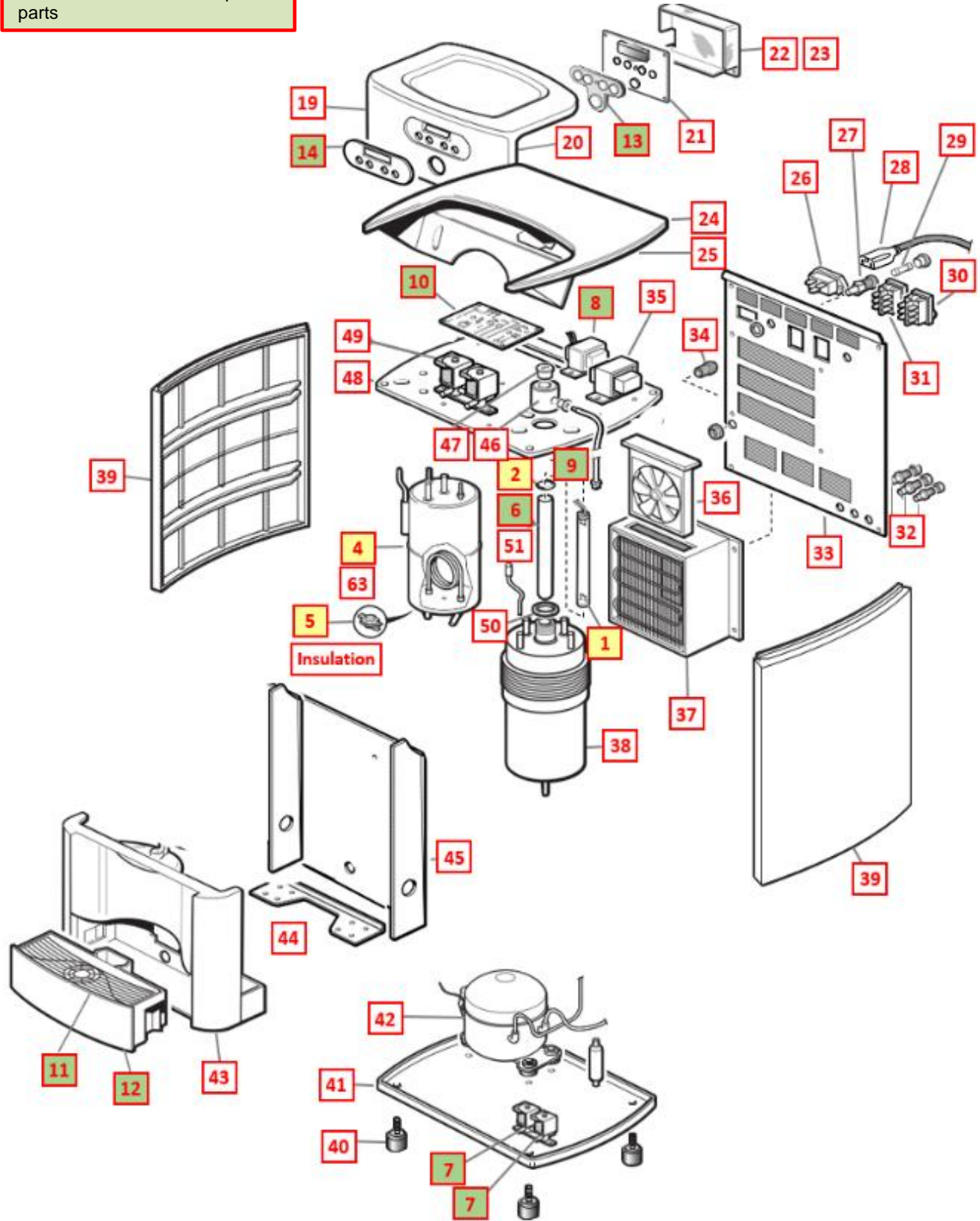

WETTED PARTS

Yellow = Consumables
 Green = Recommended spare parts

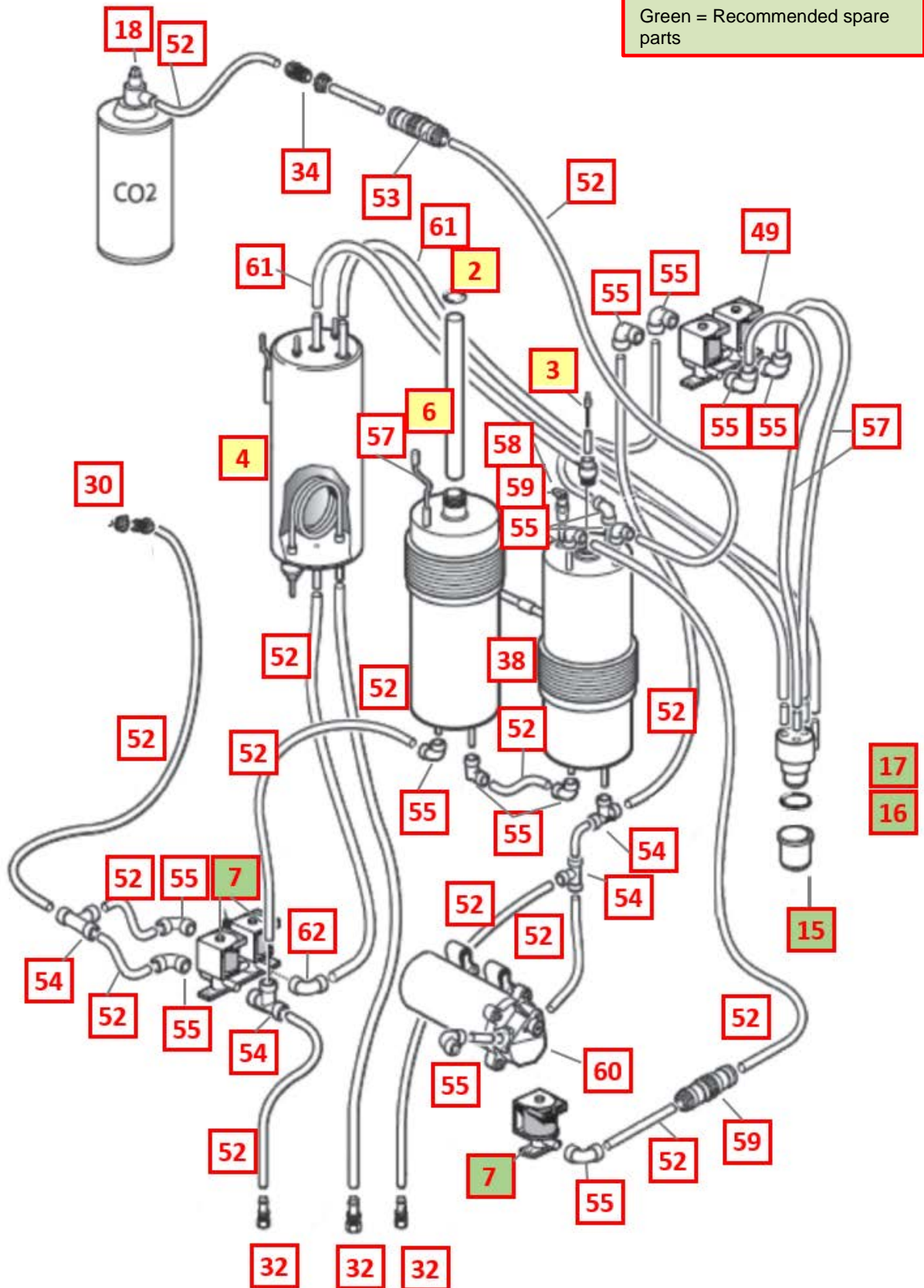

No	WLCP PN	Description	Factory PN	Stocked?	
Consumables					
1	10-7020	UV Lamp Assembly with Glow Starter	CT-2045	Yes	
2	10-2500	Black O-Ring for Quartz Sleeve	CT-2006	Yes	
3	10-7250	Sparkling Level Probe Assembly	CT-2036-L00-00	Yes	
4	10-7082	Stainless Tube Hot Tank 1.6 Liter	HT-3021	Yes	
4.1	NA	Hot Tank Thermistor <i>Part of the Hot Tank – cannot be purchased separately.</i>	HT-3002	No	
5	12-1360	Hot Tank Overload – Reset 105°C (221°F)	HT-3012	Yes	
Not Shown	01-2076	Scale Kleen	NA	Yes	
Recommended Spare Parts					
6	10-1400	Quartz Sleeve for 8W Lamp <i>Recommend stocking 1 each for every 10 units purchased</i>	CT-2002	Yes	
7	12-1500	Solenoid Valve <i>Recommend stocking 1 each for every 10 units purchased</i>	PU-4016	Yes	
8	10-3010	UV Lamp Ballast 110V/60Hz <i>Recommend stocking 1 each for every 10 units purchased</i>	EL-5006-A CN	Yes	
9	10-3011	UV Lamp Sensor (CDS) with wire <i>Recommend stocking 1 each for every 10 units purchased</i>	EL-5007	Yes	
10	10-7090	Main PCB <i>Recommend stocking 1 each for every 10 units purchased</i>	EN-6067-A	Yes	
11	12-8150	Drip Tray Grill – Charcoal <i>Recommend stocking 2 each for every 10 units purchased</i>	PL-1152	Yes	

12	10-7074	Charcoal Drip Tray Body – Waterlogic Logo <i>Recommend stocking 2 each for every 10 units purchased</i>	PL-1253-CN	Yes	
12.1	10-7092	Drip Tray Harness <i>Recommend stocking 1 each for every 10 units purchased</i>	EL-5041	Yes	
12.2	10-4006	Drip Tray Body Clip (Metal) <i>Recommend stocking 2 each for every 10 units purchased</i>	EN-6038	Yes	
12.3	10-7057	Drip Tray Sensor & Retaining Bracket <i>Recommend stocking 2 each for every 10 units purchased</i>	ST-8102	Yes	
13	10-7225	Silicon Button Key Mat <i>Recommend stocking 1 each for every 10 units purchased</i>	PL-1098	Yes	
14	10-7077	Display Label <i>Recommend stocking 1 each for every 10 units purchased</i>	PL-1102	Yes	
15	10-3048	Faucet Nipple – Blue with Screen <i>Recommend stocking 1 each for every 10 units purchased</i>	PL-1013	Yes	
16	10-2600	Natural Faucet O-Ring – Silicon White <i>Recommend stocking 1 each for every 10 units purchased</i>	CT-2007	Yes	
17	12-5235	Faucet - 3-way <i>Recommend stocking 1 each for every 10 units purchased</i>	PL-1212-CN	Yes	
18	AK-0003-L00	CO2 Pressure Regulator with tamper proof adjuster, preset to 35-45 psi, single output pressure gauge, inline shut-off valve, ¼ quick connect fitting, safety relief, and CO2 CGA-320 thread adapter. <i>Recommend stocking 1 each for every 10 units purchased</i>	AK-0003-I00-00	Yes	

Remainder of Parts					
18.1	NA	CO2 Pressure Regulator O-Ring	10-7036	Yes	
19	10-7070	Front Door Panel Charcoal <i>Sold Separately:</i> Display Label P/N 10-7077 Silicon Button Key Matt P/N 10-7225	PL-1092	Yes	
20	10-7069	Door Lock Bracket – Lower	ST-8104	No	
21	10-7210	Display PCB <i>*Use for replacement even on older units that may have a different Display PCB.</i>	EN-6073-A	Yes	
22	10-7096	Display PCB Cover	PL-1119	Yes	
23	10-7068	Hatch Panel Locking Support	ST-8103	Yes	
24	10-7073	Top Cover Charcoal	PL-1095	Yes	
25	10-7265	Electronics Cover Bracket <i>Under Top Cover</i>	ST-8278	Yes	
26	10-4013	Power Line Noise Filter, ElectroMagnetic Interference Filters (EMI)	EL-5016	Yes	
27	10-3014	Fuse Holder and Fuse 120V / 15A with One Wire	EL-5053	Yes	
28	10-3007	Power Cord 120V - 1840 mm	EL-5001-B	Yes	

29	10-3013	Fuse 120V / 15A	EL-5010	Yes	
30	10-3009	GREEN Heater/Compressor Switch	EL-5005	Yes	
31	10-3008	RED Power Switch	EL-5004	Yes	
32	14-5011	Drain valve 5/16"	CT-2031-A	Yes	
32.1	NA	Drain Valve Clamp 5/16"	CT-2046	No	
33	10-7051	Back Panel	ST-8094-A	No	
34	10-3067	Bulkhead Union 1/4" x 1/4" John Guest P/N PI1208S	PU-4028-A	Yes	
35	10-7220	Power Transformer for Sparkling	EL-5094	Yes	
36	10-1500	Fan Motor 110V (AC Axial fan)	CT-2011	Yes	
36.1	NA	Fan Bracket	ST-8227	No	
37	10-7081	Cooling Fan Condenser	CO-9023	Yes	

38	NA	Cold Tank Assly-4L Sparkling. Double Tank	CT-2032-A	No	
39	10-7072	Side Panel Silver	PL-1094	Yes	
39.1	NA	Frame Bracket - Gray Plastic	PL-1135	No	
40	10-3083	Adjustable Unit Rubber Feet	ST-8016	Yes	
41	10-7053	Bottom Shelf	ST-8096	Yes	
42	10-2200	Compressor (R134a 1/8HP) 120V/60Hz	CO-9001-A	Yes	
42.1	10-3003	Compressor Starter Relay	CO-9016	Yes	
42.2	10-5018	Compressor Overload	CO-9015	Yes	
42.3	12-1001	Filter Dryer	CO-9008	Yes	
43	10-7071	Front Hatch Panel <i>Hot Water Caution Label LP-7169 / 12-0001 required.</i>	PL-1093	Yes	
43.1	12-0001	Hot Water Caution Label – adhere to Front Upper Drip Tray Insert Panel	LP-7169	Yes	
44	10-7054	Filter Housing Bracket	ST-8097	Yes	

45	10-7050	Metal Front Frame Panel	ST-8093	Yes	
46	10-4008	UV Lamp Retaining Nut	PL-1027	Yes	
47	10-3095	CDS Fixing Rubber (Silicon)	CT-2010	Yes	
48	10-7052	Upper Shelf - Inner	ST-8095	No	
49	10-7060	Double Solenoid Valve with wire harness assembled	PU-4056-B	Yes	
50	10-3096	Cold Tank Retaining Nut	CT-2001-C	Yes	
51	10-2650	Cold Water Sensor	CT-2081-A	Yes	
52	Purchase from John Guest	JG LLD PE Tube - Blue O.D.1/4" John Guest P/N PE-08-BI-1000F-B	PU-4031	No	
53	Purchase from John Guest	JG Equal Straight Connector 1/4"(PI0408S)	PU-4010	No	
54	Purchase from John Guest	1/4" Union Tee John Guest P/N P10208S	PU-4011	No	
56	Purchase from John Guest	1/4" Union Elbow John Guest P/N P10308S	PU-4008-A	No	

57	Purchase from John Guest	JG LLDPE Tube - Blue 8mm John Guest P/N PE-0806-100M-B	PU-4014	Yes	
58	10-7245	Upper Safety Valve 1/4" for Sparkling Unit	CT-2037-100-00	Yes	
58.1	NA	Silicon O-Ring for Upper Safety Valve (Red)	PL-1271	No	
59	10-7270	JG Non-Return Valve 1/4"(1/4SCV)	PU-4057	Yes	
60	10-7235	Booster Pump - Sparkling	CT-2035-E	Yes	
60.1	10-7240	Pump Bracket	ST-8098	Yes	
61	10-7040	Silicon Tube 5/16" for Hot Water	PU-4064	Yes	
62	Purchase from John Guest	5/16" x 1/4" Reducing Elbow John Guest P/N PI211008S	PU-4007	No	
63	12-8006	Hot Tank Fixing Bracket 400mm	ST-8120	Yes	
Not shown	Purchase from John Guest	JG Stem Elbow Connector 1/4" * 1/4" - Acetal PI220808S)	PU-4066	No	
Not shown	AK-0014	Flow Restrictor 1.2 mm Hole	AK-0014	No	
Not shown	10-3007	Power Cord 120V – 1840 mm	EL-5001-B	Yes	

WL500 BASE CABINET DRAWING AND ASSEMBLY INSTRUCTIONS

Base Cabinet Kit AK-0005

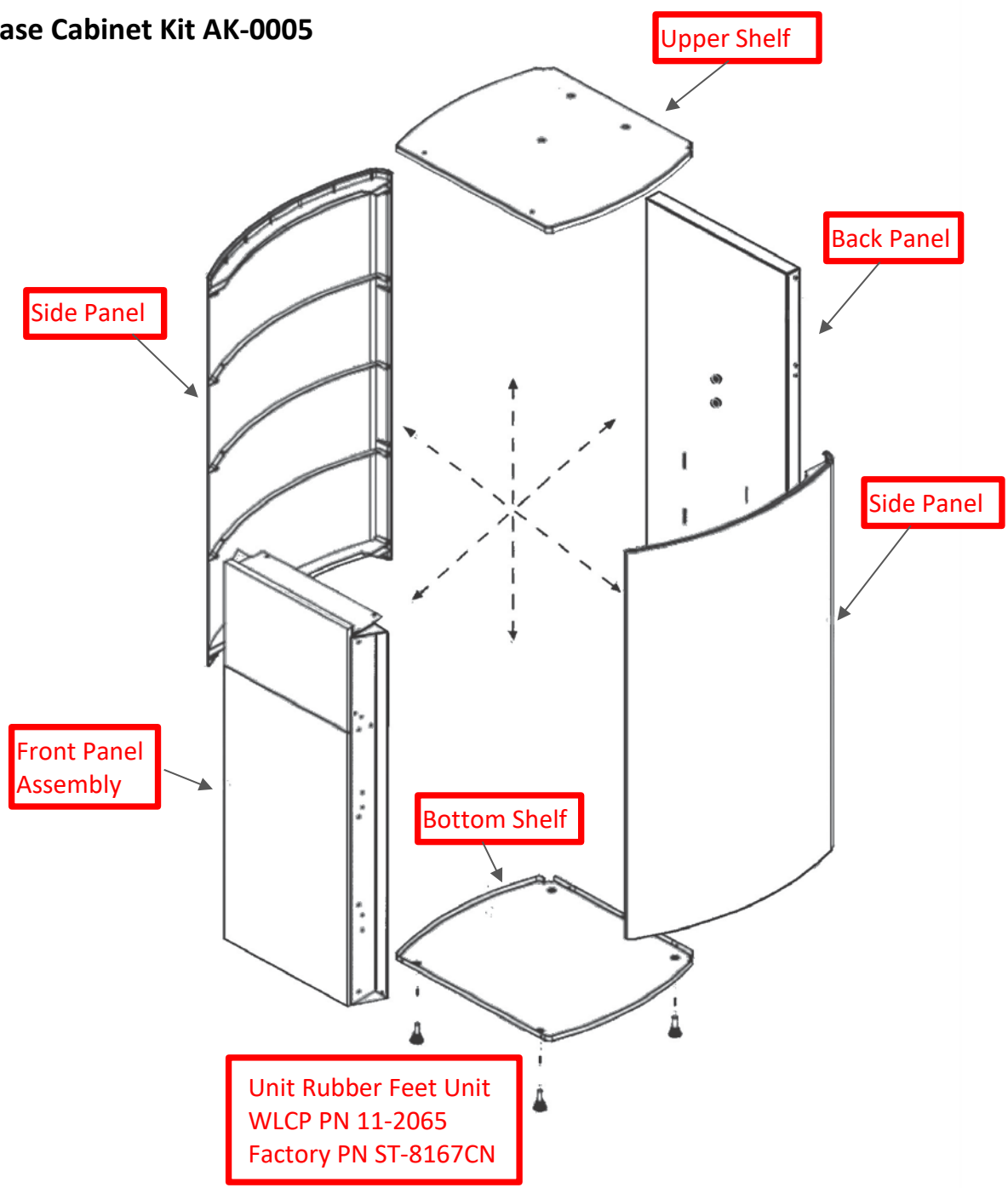

BASE CABINET (AK-0005) ASSEMBLY INSTRUCTIONS

Step 1

Install Unit Rubber Feed to the Bottom Shelf.

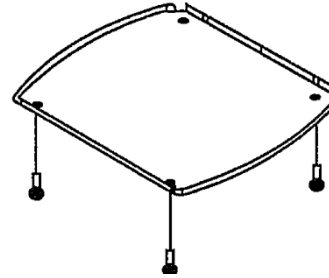

Step 2

Attach the Back Panel to the Bottom Shelf using 3 of the screws provided.

- The back lip of the Bottom Shelf has 3 holes.
- The front lip of the Bottom Shelf has 2 holes.

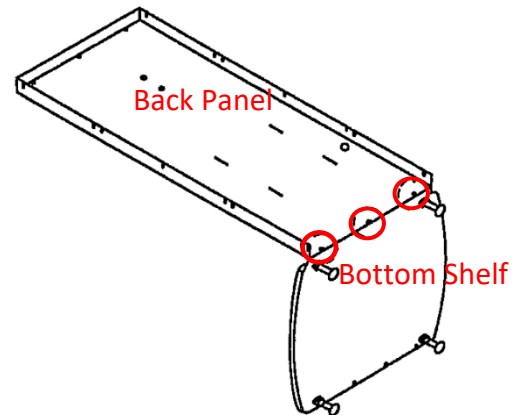

Step 3

Attach the Upper Shelf to the Back Panel using 3 screws provided.

- The back lip of the Upper Shelf has 3 holes.
- The front lip of the Upper Shelf has 2 holes.

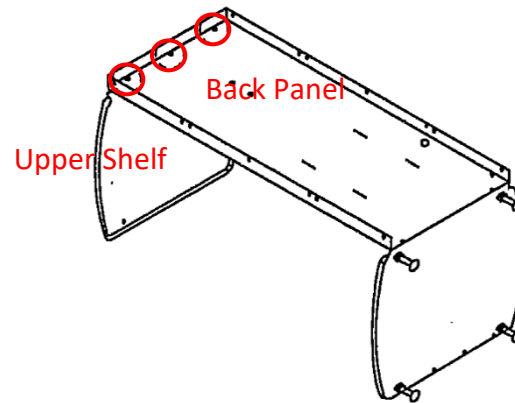

Step 4

Mount the Front Door and Frame Assembly to the front edges of the Upper and Bottom Shelves. Upper and Bottom Shelf edges fit inside of Door Assembly edges.

- 5 screws each at front and back edges
- 11 screws per Side Panel

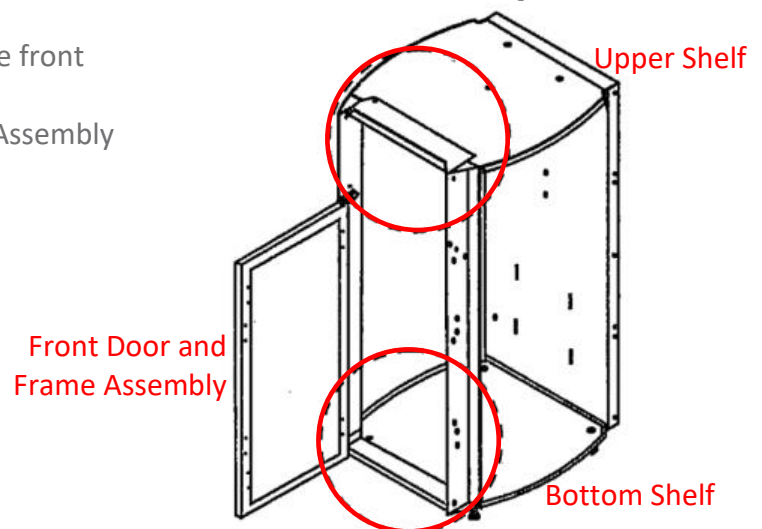

Step 5

Fasten the Side Panels to the frame.

- The Side Panels fit either side, with the sharper curved edge placed toward the rear.
- Align the side Panels using the plastic tabs that protrude through the metal frame.

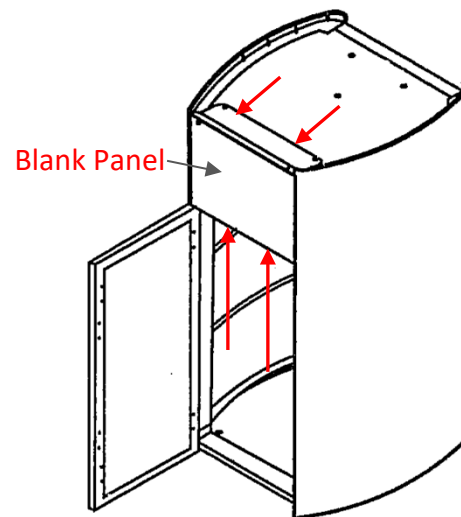
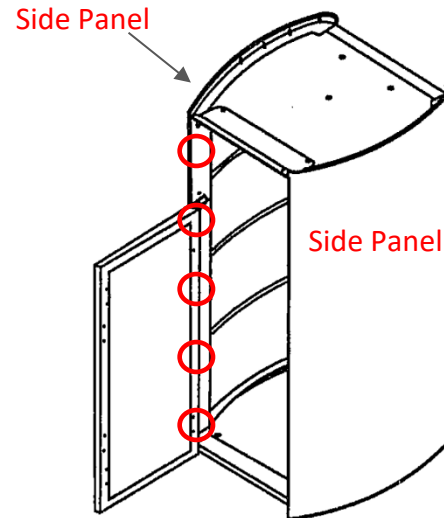

Step 6 - Front Panel Assembly Installation Assembly

Skip this step if the optional Cup Holder will be installed

- Attach the Blank Panel using 4 screws provided.

⚠ WARNING! DISPENSER COULD TIP OR FALL. *Install unit on a firm, flat, and level surface and secure the **WL500 Water Treatment System** to the Base Cabinet with the Safety Screw (aka Lock Screw) provided to lock the components together. Never place heavy items on top of unit and never climb, stand, or hang on unit or storage cabinet to prevent injury and damage.*

Step 7

Locate and align the **WL500 Water Treatment System** on top of the Base Cabinet.

- Lock together using the safety bolt (aka locking bolt) provided.

WL500 CUP DISPENSER (AK-0007) DRAWING AND ASSEMBLY INSTRUCTIONS

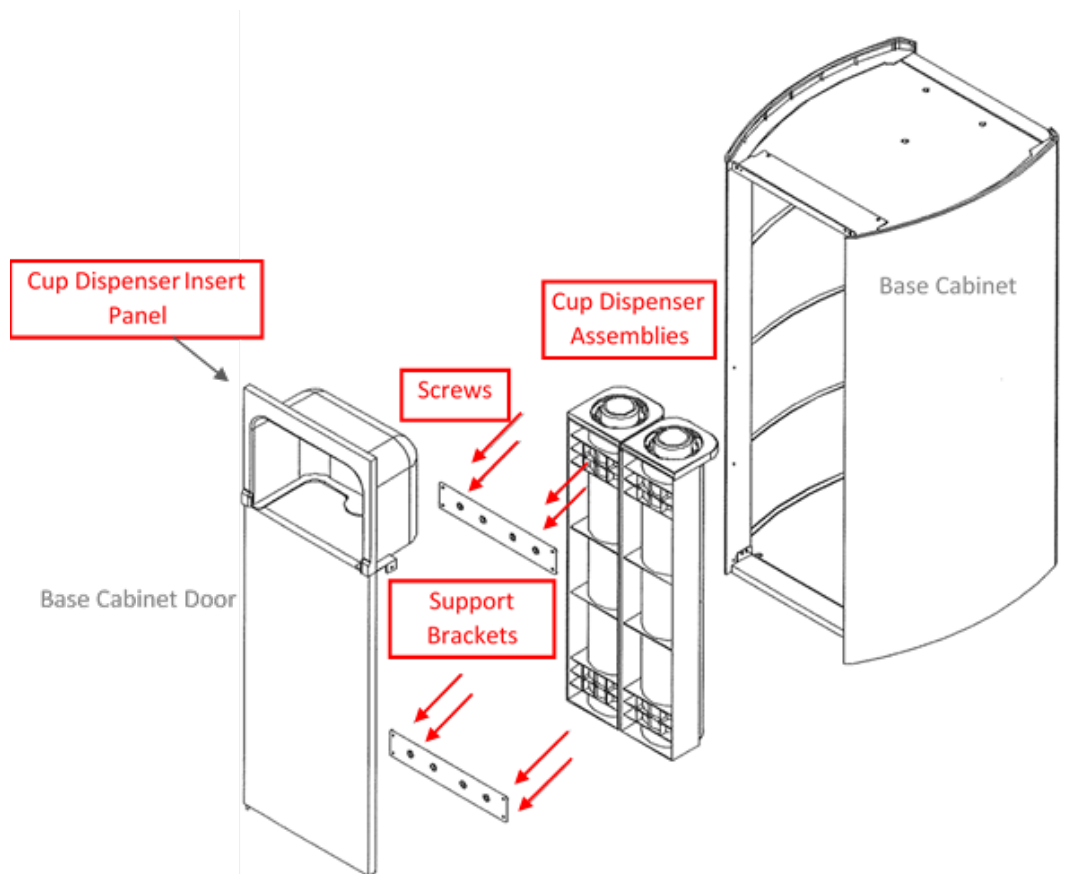

Step 1

Fasten Support Brackets to the back-side of the cup holders as shown with the 8 screws provided.

Step 2

Fasten the Cup Dispenser Insert Panel into the Base Cabinet.

Note: This will require maneuvering of the Insert Panel for proper alignment. Take care not to break the plastic tabs on the Insert Panel.

Step 3

Fasten the Cup Holder Assemblies to the Base Cabinet Door.

Cup Dispenser Kit AK-0007 Contents:

- Cup Dispenser Insert Panel
- (2) Support Brackets
- (2) Cup Dispenser Assemblies
- (8) Screws

Cup Dispenser Specifications

- Accepts cups from 4 oz. to 14 oz.
- Cup Opening Minimum Diameter is 2 ½" (66 mm)
- Cup Opening Maximum Diameter is 3 ¼" (84 mm)

WL500 FLOW DIAGRAM

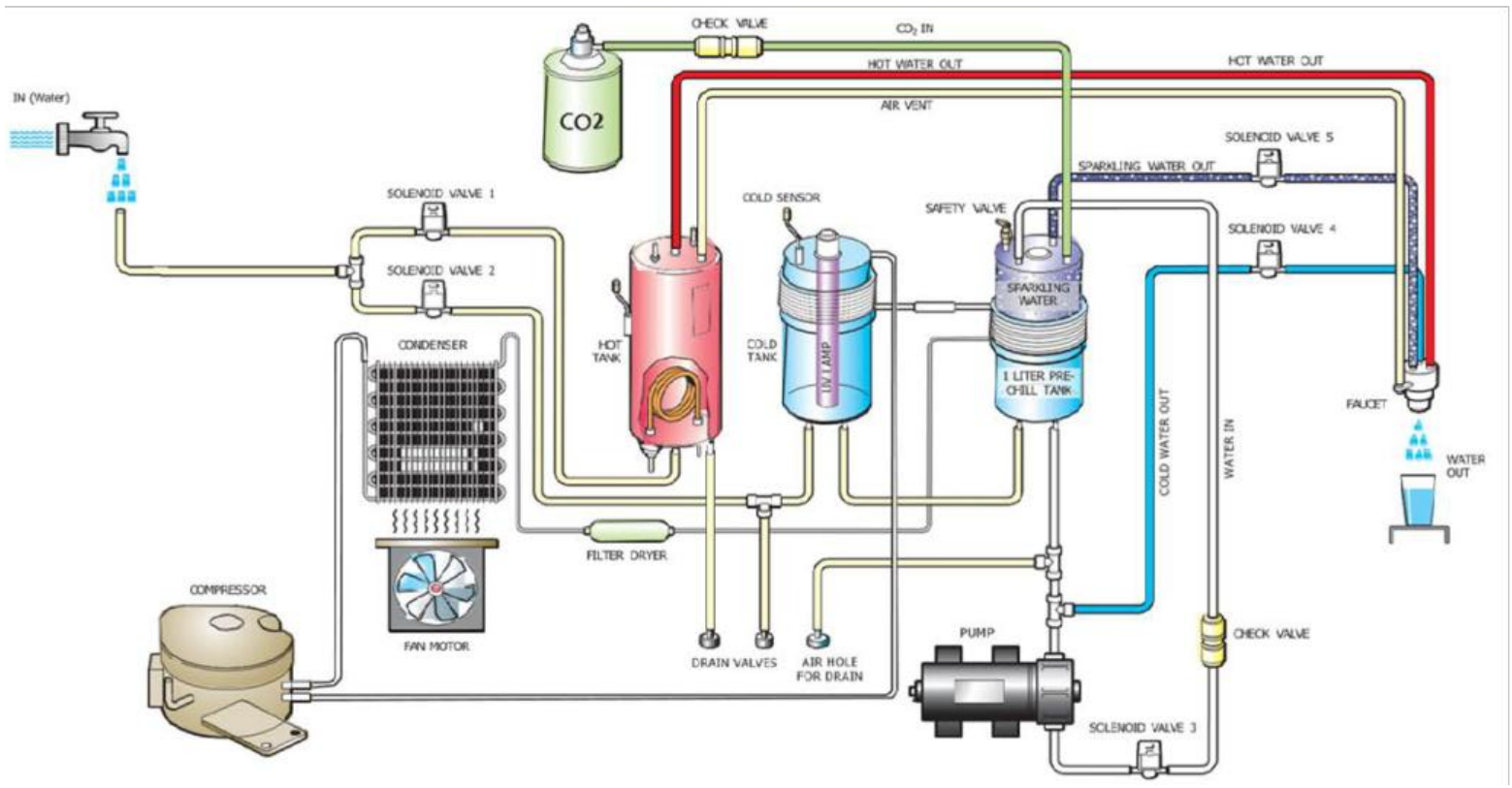

PRE-INSTALLATION PROCEDURES

⚠ DANGER! ELECTRICAL SHOCK HAZARD.

Only qualified personnel who have read and understand this entire manual should attempt to install, or service this unit, failure to do so could result in death or serious injury. DO NOT plug into an electrical supply until specifically instructed.

⚠ WARNING! ALWAYS SANITIZE BEFORE USE.

Sanitize before use to eliminate any potential microbiological contaminants.

Materials Needed:

- Personal Protective Equipment. Rubber or Nitrile Safety Gloves and Protective Eyewear
- Phillips Screwdriver.
- Temperature Gauge.
- Water Pitcher or Container to collect water from the faucet
- 5-gallon container or drain basin
- Sanitizer - Household Bleach (5.25% Sodium Hypochlorite) or Citric Acid Based Cleaner
- ¼" Plastic Tubing, at least 4 feet in length, and assorted ¼" quick connect fittings.
- TDS Meter and Test Strips for measuring chlorine. - Optional
- 1/8 NPT Female Thread to ¼" Compression Fitting (Used to connect hose to drain fittings)

1. Unpack the **Waterlogic WL500 Water Treatment System** and check exterior for damage.

⚠ WARNING! WL500 WATER TREATMENT SYSTEM IS HEAVY.

Use proper lifting aids and handling techniques to avoid injury. Use assistance as single person lift could cause injury. Always drain before handling and transporting and handling to reduce the weight of the unit.

2. Remove the Retaining Screw that is located directly in front of the faucet nipple. Refer to **Figure 1**. Removing this screw will allow access to the inside serviceable components (Filters and UV Lamp).
3. Open the Front Hatch Cover by lifting up and hinging outward. Front Hatch Cover can be removed by carefully squeezing Panel base and pulling over Hinge Pins.



Flush Filters

⚠ CAUTION! FILTERS FLUSH REQUIRED.

WL500 Water Treatment Systems are not supplied with Filters. Filters should be configured to optimize your system. Filters need to be configured and specified to do the job given the local water conditions, usage, maintenance schedule, and placement restrictions.

In order for our Filters to perform as represented and to provide the best quality water possible, it is essential that Filters be replaced periodically. The frequency of Filters changes depends upon your water quality and your water usage. For example, if there is a lot of sediment and/or particles in your water, then you will have to change your Filters more frequently than a location with little to no sediment. Be sure to replace your Filters whenever you notice a decline in the performance, whether it is a drop-in flow rate and/or pressure or an unusual taste in the water.

4. Flush thoroughly per Filters manufacturers' recommendation with fresh water to drain.
5. Once flushed, install the Filters. Following the flow direction on the Filters.

NOTE: Filters should not be flushed prior to 24 hours before installation to limit Microbial Growth.

Sanitizing

Sanitize using a household bleach solution or other approved cleaner throughout the cold and sparkling water circuits. Follow all instructions on the sanitizer and flush with fresh water through the faucet until odor and taste is acceptable.

⚠ WARNING! USE PROPER PERSONAL PROTECTIVE EQUIPMENT

Always ensure proper ventilation and use proper personal protective equipment such as gloves and eye protection when using chemicals. Refer to Material Safety Data Sheet for specific requirements of each chemical product. Take all necessary precautions to prevent sanitizer from contacting eyes, clothing, and any other surfaces in could damage (carpets).

6. Remove the UV Cover Plate and set aside – 2 Screws.
7. Disconnect the UV Lamp harness and carefully remove the UV Lamp from the Quartz Sleeve.

⚠ CAUTION! UV SYSTEM IS FRAGILE. *Never handle the UV System with bare hands. UV Lamp and Quartz Sleeve must be free of oils and contaminants to ensure proper operation.*

8. Remove UV Sensor from the side of the Cold Tank/Quartz Sleeve Retaining Cap.
9. Unscrew Cold Tank/Quartz Sleeve Retaining Cap and remove the Quartz Sleeve. This may require Top Cover to be removed to access properly and facilitate removal.
10. Mix ½ gallon of sanitizer per directions or use Bleach Solution (1 teaspoon = 1/6 oz. = 5 ml = ½ cap full) of household bleach (Sodium Hypochlorite 5 - 10% Concentration) with 1/2 gallon of water. Always ensure sanitizer is compatible with stainless steel and acetyl plastic.
11. Pour sanitizer solution into Cold Tank thru funnel or spout. You may add concentrated sanitizer (½ cap bleach) directly into empty Cold Tank instead of premixing.

12. Inspect and clean Quartz Sleeve and O-ring. Reinstall the Quartz Sleeve and Quartz Sleeve retaining nut. Tighten firmly to ensure proper seal. Over-tightening can cause damage.
13. Reinstall the UV Lamp and UV Sensor. Take care not to touch with fingers.
14. Connect 40-60 psi regulated, potable water supply to the water inlet bulkhead fitting located on the back of the unit. Turn on water supply and check for leaks.
15. Connect CO₂ gas line to **WL500 Water Treatment System** Bulkhead Inlet Fitting. Regulate to 35-45 psi. Turn on CO₂.

⚠ WARNING! HIGH PRESSURE CO₂ GAS. Use/Handle in accordance with all safety standards.

⚠ DANGER! ELECTRICAL SHOCK HAZARD.

Do not plug in unit unless qualified. Only qualified personnel who have read and understand this entire manual should attempt to install or service this unit.

16. Connect **WL500 Water Treatment System** to power, and turn on the RED Power Switch I=ON.



⚠ CAUTION! NEVER TURN ON HEATER BEFORE FILLING HOT TANK.

GREEN Compressor/Heater Switch must be in the O=OFF position while the Hot Tank is empty. Damage could occur within one minute and the overload (high limit) will require manual reset if heater is turned on with an empty Hot Tank.

Fill the Cold Circuit with Sanitizer

17. Wait 10 seconds for the unit to perform its diagnostics checks, depress the main dispensing button on the front control Panel until cold water/sanitizing solution comes out the faucet.

NOTE: Container and drain basin will be required to catch the water from the faucet.

⚠ WARNING! Use Personal Protective Equipment. Gloves and Eye Protection Required. The first 2 or 3 gallons of water will contain concentrated sanitizer. Use extreme care!

Fill the Sparkling Chamber with Sanitizer

18. The sanitizer solution will be injected into the Sparkling Tank by the booster pump once unit is turned on and the Cold Tank is full. Dispense 1 liter of sparkling water into container and let Sparkling Chamber regenerate to ensure the Sparkling Tank is full of sanitizer.

⚠ CAUTION! USE SANITIZER COMPATIBLE WITH STAINLESS STEEL AND ACETAL PLASTIC.

Do not allow the sanitizer solution to remain in the system for more than 10-15 minutes unless otherwise directed by the sanitizer manufacturer.

Flushing the Sanitizer from the Machine

19. Place a pitcher, catch basin, or other container under the faucet of the **WL500 Water Treatment System**.

20. Flush the Cold Tank. Run several gallons of water through the faucet by dispensing cold water to dilute and remove the sanitizer from the cold circuit. You can use chlorine test strips to evaluate the water. Once the sanitizer odor/taste has been flushed out of the cold side of the machine, move to the sparkling circuit.
21. Flush the Sparkling Chamber. Dispense sparkling water until only gas comes out. Let the Sparkling Tank regenerate. This should take approximately 1 minute, 20 seconds. Listen for the booster pump to turn off. Repeat the sparkling water regeneration until the sanitizer odor/taste has been flushed out.
22. The sanitization process for the Cold and Sparkling Circuits is now complete.

Fill the Hot Tank

23. Press the Hot Button (Button 3), followed by the main dispensing button to fill the Hot Tank. Water will dispense from the faucet once the Hot Tank is full. Flush until water is clear.

⚠ WARNING! HOT CIRCUIT IS NOT SANITIZED. WATER MUST EXCEED 171° F

Water in the hot circuit is not sanitary until the temperature over 171°F for 5 minutes. Do Not Ingest and avoid contact until heater is turned on for at least 5 minutes.

UV System Functional Test

⚠ WARNING! ULTRAVIOLET RADIATION. Protect your skin and eyes against ultraviolet rays.

Never look directly at an operating UV light. Disconnect before removing.

24. Dim or shield the overhead lights and peer into the machine, on top of the Cold Tank, at the UV connector and Retaining Cap. The blue glow indicates that the lamp is lit.
25. Find the white wires delivering power to the top of the lamp assembly. Follow the wires back until the electrical connector is found. Disconnect the electrical connector and verify that the UV Lamp alarm annunciates.
26. Reconnect the UV Lamp wire connector, and cycle the Red Power Switch to clear the alarm.

Compressor Test

27. Switch on the GREEN Compressor / Heater Switch (*I=ON*). Always ensure tanks are full of water before turning on the heater or the overload (high limit) will open and require manual reset. Once the Compressor starts, the fan condenser also will start. Verify the fan has started by feeling for the discharge of air at the rear grill of the machine. Heat exchange is a signal that the refrigeration system is working.

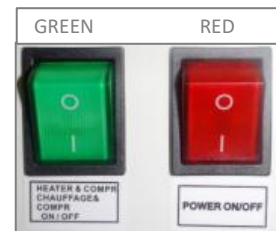

28. Monitor the Cold Tank temperature on the front display of the unit by changing the Temp Display to RANGING. It will take about 45 minutes for the unit to chill down to the default set point temperature of 41°F assuming ambient inlet water of 75°F.

29. Once the machine reaches its target temperature, the Compressor and fan will shut off. Draw a glass of cold water and verify it has been chilled to proper temperature.

Heater Test

30. Always ensure tanks are full of water before turning on the heater or the overload (high limit) will open and require manual reset. It will take the heater approximately 10 minutes to heat the water from ambient 75°F to the factory set point of 189°F. You can monitor the Hot Tank temperature by selecting the hot button when the Temp Display is RANGING. Dispense a cup of hot water to ensure the temperature/odor/taste is acceptable.

⚠ WARNING! VERY HOT WATER CAN BURN OR SCALD.

Hot water should be dispensed carefully into insulated container to avoid injury.

Drain the WL500 Water Treatment System for Transport

31. Drain the **WL500 Water Treatment System** for transportation per the Draining Instructions in this manual.

⚠ WARNING! STORE UNIT EMPTY. ALWAYS SANITIZE BEFORE REUSE.

The unit must be completely drained and sealed before storing to avoid stagnation and reduce microbiological contamination (potential bacterial growth).

SANITIZING SPARKLING TANK ONLY

⚠ DANGER! ELECTRICAL SHOCK HAZARD.

Only qualified personnel who have read and understand this entire manual should attempt to install, or service this unit, failure to do so could result in death or serious injury. DO NOT plug into an electrical supply until specifically instructed.

⚠ WARNING! ALWAYS SANITIZE BEFORE USE.

Sanitize before use to eliminate any potential microbiological contaminants.

Materials Needed:

- Personal Protective Equipment. Rubber or Nitrile Safety Gloves and Protective Eyewear
- Phillips Screwdriver.
- Temperature Gauge.
- Water Pitcher or Container to collect water from the faucet
- 5-gallon container or drain basin
- Sanitizer - Household Bleach (5.25% Sodium Hypochlorite) or Citric Acid Based Cleaner
- ¼" Plastic Tubing, at least 4 feet in length, and assorted ¼" quick connect fittings.
- TDS Meter and Test Strips for measuring chlorine. - Optional
- 1/8 NPT Female Thread to ¼" Compression Fitting (Used to connect hose to drain fittings)

1. Unpack the **Waterlogic WL500 Water Treatment System** and check exterior for damage.

⚠ WARNING! WL500 WATER TREATMENT SYSTEM IS HEAVY.

Use proper lifting aids and handling techniques to avoid injury. Use assistance as single person lift could cause injury. Always drain before handling and transporting and handling to reduce the weight of the unit.

2. Remove the Retaining Screw that is located directly in front of the faucet nipple. Refer to **Figure 1**. Removing this screw will allow access to the inside serviceable components (Filters and UV Lamp).
3. Open the Front Hatch Cover by lifting up and hinging outward. Front Hatch Cover can be removed by carefully squeezing Panel base and pulling over Hinge Pins.



⚠️ WARNING! RELIEVE WATER AND CO₂ PRESSURE BEFORE ATTEMPTING TO SANITIZE SPARKLING TANK.

Accessing Sparkling Tank

4. Remove Sparkling Water Level Sensor Wires
5. Remove Sparkling Water Level Sensor Fitting and Probe to access Sparkling Tank.

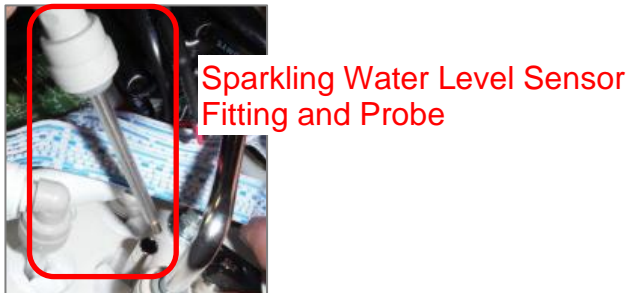
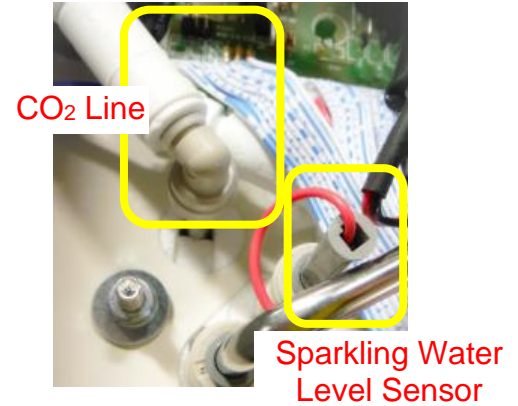

6. Remove Fitting from CO₂ Line
7. Attach Water Inlet Valve



8. Add 1-2 drops of Bleach into the Sparkling Tank through the Sparkling Water Level Sensor line.



9. Connect Drain Water line and fitting to the Sparkling Water Level Sensor line.
10. Flush 3-5 Gallons through Sparkling Tank. There should be no bleach smell after flushing.
11. Reconnect Sparkling Water Level Sensor, Fitting and Wires.



WL500 DRAINING INSTRUCTIONS

⚠ WARNING! *WL500 WATER TREATMENT SYSTEM IS A HEAVY OBJECT.*

Use proper lifting aids and handling techniques to avoid injury. Use assistance as single person lift could cause injury. Always drain before handling to reduce weight.

Draining Notes

There are 3 tanks and a booster pump circuit that must be drained in the **WL500 Water Treatment System**. The cold still water circuit of the **WL500 Water Treatment System** consists of a 2-liter Cold Tank, a 1-liter pre-chill chamber and a booster pump circuit that is sealed and must be vented to drain. The booster pump will have some water in the circuit that must be purged to remove it. The Sparkling Chamber does not have a vent or drain port and must be dispensed until empty (pushing CO₂ gas only out of the faucet) to clear the water from the Sparkling Chamber. It is critical to clear the cold still water before draining the Sparkling Chamber to ensure the pump does not inject water back into the Sparkling Chamber. The Hot Tank has a drain port and is the only tank that is open to atmosphere through the vent and faucet.

Prior to draining the Hot Tank, turn the GREEN Compressor/Heater Switch off (*O=OFF*), and dispense 2 liters of hot water from the machine. As hot water is dispensed from the faucet of the unit, colder water will be introduced into the Hot Tank. Since the GREEN Compressor/Heater switch is turned off the heater will not energize and heat the incoming tap water. Following this precaution prevents exposing personnel and equipment (drains, catch basin, etc.) to scalding hot water.

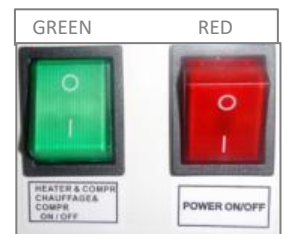

Disable Cold and Hot Tanks

1. Turn off the GREEN Heater / Compressor Switch to disable the heater and Compressor. *O=OFF*
2. Dispense 2 liters of water through the Hot Tank to cool the water temperature in the Hot Tank and avoid burns.

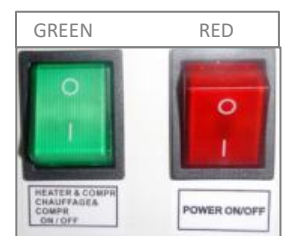

⚠ WARNING! *VERY HOT WATER CAN BURN OR SCALD.*

Hot water should be dispensed carefully into insulated container to avoid injury.

Turn off Water Supply and Bleed Water Pressure

3. Isolate the unit from feed water by turning off the supply.
4. Dispense cold still water to relieve any pressure built up in the system.
5. Remove the water supply line from the unit.
6. Install dust cap or plug into water supply line bulkhead fitting.

Drain the Cold Still Water Tanks and Circuit

7. Open front Hatch Panel by unscrewing the retaining screw in front of the faucet until it is flush with the faucet. Slide front Hatch Panel up and out.
8. Remove the UV light cover plate and access the UV Lamp and quartz sleeve.

⚠ WARNING! ULTRAVIOLET RADIATION. *Protect your skin and eyes against ultraviolet rays. Never look directly at an operating UV light. Disconnect UV Lamp before removing.*

9. Unplug the UV Lamp and remove UV Lamp.
10. Remove the UV indicator sensor from the Quartz Sleeve retaining nut.
11. Unscrew the Quartz Sleeve retaining nut and remove Quartz Sleeve to vent the cold circuit.
12. Remove the Cold Tank drain line cap and drain the 2 liters into a container.
13. Remove the pre-chill drain line cap and drain the 1 liter of water from the pre-chill chamber and the booster pump circuit.
14. A total of 3 liters of cold still water will drain from the unit.

Drain the Sparkling Water Chamber

15. Dispense all sparkling water out of the Sparkling Chamber through the faucet of the **WL500 Water Treatment System** into the drip tray (holds 1.5 liters) or other container until only CO₂ gas is dispensed. The Sparkling Chamber holds a maximum of 1 liter of water.
16. Release the dispense button and let the booster pump cycle on to inject any remaining water from the still water feed circuit and pump into the Sparkling Tank for 30 seconds.
17. Dispense sparkling water to clear any remaining water from the Sparkling Tank through the faucet until only CO₂ gas is coming out.

18. Turn off the RED Power switch (*O=OFF*). This will kill power to the pump ensuring that no water is injected back into the Sparkling Chamber and shut off the all Solenoid Valves. CO₂ should stop dispensing.



19. Turn off the CO₂ gas supply at the bottle (screw shut off valve all the way in).
20. Release gas pressure in the Sparkling Tank by opening (flipping up) the Pressure Relief Valve (PRV) on top of the Sparkling Chamber to vent the system. May remove top cover to access.
21. Remember to close the Pressure Relief Valve once all pressure is relieved.
22. Remove the CO₂ supply line from the unit.
23. Install dust cap or plug CO₂ gas inlet bulkhead fitting.

Drain the Hot Water Tank

24. Remove the Hot Tank drain cap from the rear of the unit.
25. Drain 1.6 liters of hot water into suitable container.

Reassemble the Unit

26. Reinstall all drain caps.
27. Reinstall the Quartz Sleeve.
28. Reinstall the Quartz Sleeve Retaining Cap firmly. Do not over tighten O-ring seal.
29. Reinstall the UV Lamp. Be careful not to touch UV Lamp surface as oils from your hands can cause dark spots and impact the performance of the system. Always wipe off lamp with alcohol wipe or equivalent if needed. Ensure lamp wires are not crossed and never force lamp into the sleeve to avoid damage.
30. Reconnect UV Lamp.
31. Reinstall the UV sensor into the Retaining Cap.
32. Reinstall top cover and the UV Lamp cover plate.
33. Ensure the front display PCB ribbon connectors are securely attached and completely seated to avoid problems.
34. Close front Hatch Panel and tighten the locking screw to secure.

WL500 QUICK START INSTALLATION GUIDE

Critical Requirements

Establish Food Grade [CO₂ Supply and regulate to 35-45 psi](#). This will produce optimum sparkling water and CO₂ concentration when combined with 46 F degree or cooler water. Regulate the [Water Supply to 40–60 psi](#). ALWAYS use a pressure regulator and leak protection when installing units.

- 1) Prior to setting up the **WL500 Water Treatment System** machine, open the knock-out on the back panel of the base cabinet to allow routing of the CO₂ pipe if using the base cabinet.
- 2) Unpack the **WL500** and set on top of countertop or base cabinet so that the side panels of the machine align with the side panels of the base cabinet.

- 3) Secure the **WL500** to the base cabinet using the bolt provided in the base cabinet. Note that the connection point is accessed from the underside of the base cabinet. The bolt threads into the **WL500** base plate and locks the unit together.



Mounting Bolt Here

- 4) Install a regulator onto a 5lb or 10lb food grade CO₂ bottle and purge some gas from the bottle. Regulate output to 35-45 psi. Close the regulator outlet valve, and secure in place.
- 5) Route a ¼-inch pipe from the outlet fitting of the CO₂ regulator through the knock-out in base cabinet up to the CO₂ IN bulkhead fitting on the back of the **WL500**. Always secure the CO₂ bottle with a chain or strap to prevent tipping.
- 6) Establish 40–60 psi 0.5 gal/min potable water supply. Leak Protection is recommended.

- 7) Supply power to the **WL500**, and turn on the RED Power Switch *I=ON*. The GREEN Heater / Compressor switch MUST remain OFF (*O=OFF*) until the **WL500** tanks are filled or Hot Tank Overload will trip and require reset.

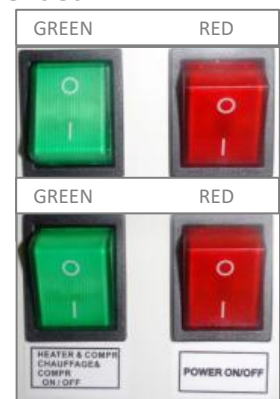

- 8) Fill the Hot, Cold, and Sparkling Tanks by dispensing until a solid stream of water flows from each. The Sparkling Tank will self-fill after the Cold Tank is filled. Once all tanks are full, turn the GREEN Heater / Compressor switch on to activate the heating and chilling systems(*I=ON*).

- 9) Slowly open and supply CO₂ to the **WL500** after all tanks are filled and air is purged from the system. This will ensure the sparkling pump will not time out after 10 minutes and create a “No Water Supply” error due to over pressure condition in the carbonation chamber.

- 10) Allow the unit to chill the water down to the 41°F set point and then regenerate the Sparkling Tank by dispensing the entire batch (0.8 liters) of sparkling water until only CO₂ gas flows from the faucet. Water must be cold (below 46°F) to generate premium tasting sparkling water. Do not set cold temperature below 41°F or freezing in the sparkling chamber may occur.

INSTALLATION PROCEDURES

Safety and Installation Guidelines

Ensure all Local, State, and Federal Laws and Codes including health and safety guidelines are met when installing **Waterlogic** Equipment. Only qualified service technicians should attempt installation and service of **Waterlogic** Equipment.

- ⚠ WARNING! ELECTRICAL SHOCK HAZARD.** Always unplug (isolate from power supply) to prevent electrical shock except where electrical tests are specified.
- ⚠ WARNING! IMPROPER SUPPLY OR CONNECTION CAN RESULT IN RISK OF SHOCK.** Connect to a 15 amp 120V 60Hz properly grounded outlet (GFI is recommended). Ensure polarity is correct and always use a 3-prong outlet. Consult a qualified electrician if you have any questions.
- ⚠ WARNING! USE ONLY Waterlogic SUPPLIED POWER CORD (WLCP PN 10-3007).** Locate system within 5 feet of power supply. Never use an extension cord or adapter. Do not use a damaged power cord or plug. Keep power cord out of heavy traffic areas and away from heat sources. Do not, under any circumstances, remove ground prong or alter the power cord. Never pull the power plug from the outlet with a wet hand or allow the plug to get wet. Failure to use the supplied power cord will void UL Certification and Warranty.
- ⚠ CAUTION! INDOOR USE ONLY.** Never exposed to direct sunlight, heat sources, or ambient air temperature above 97°F (36°C) or below 50°F (10°C). Install indoors and keep unit away from excessive humidity. Never expose to freezing temperatures. Ensure there is adequate clearance around the unit to allow refrigeration system condenser to dissipate heat. Warmer environments require more clearance around the unit. Minimum clearance around all surfaces of the machine is 2-inches. Installs where the ambient temperature exceeds 80°F, require a minimum of 4-inches clearance for proper heat dissipation and efficient operation.
- ⚠ CAUTION! USE A WATER PRESSURE REGULATOR.** **Waterlogic** will not be responsible for injury or damage caused by excessive water pressure. Operating pressure must be 40 psi to 60 psi. Be aware any of potential pressure surges caused by building/municipal pumping stations.
- ⚠ CAUTION! USE UV STABILIZED SUPPLY LINES.** Feed the unit with a potable ambient or cold-water supply only. Feed water over 105° F (40°C) can damage the treatment components. Water block devices and external leak detectors are strongly recommended. Locate the unit as close to the water supply and the electrical connections as possible.
- ⚠ WARNING! HIGH PRESSURE CO₂ GAS.** Use/Handle in accordance with all safety standards.
- ⚠ WARNING! STORE UNIT EMPTY. ALWAYS SANITIZE BEFORE USE.** The unit must be completely drained and sealed before storing to avoid stagnation and reduce microbiological contamination (potential bacterial growth). Sanitize before use to eliminate any potential microbiological contaminants

WL500 Water Treatment System can be combined with RO Filtration Systems. RO will require a drain connection. Refer to all applicable plumbing codes and standards in your area for these requirements (air gap connections and back flow prevention may be necessary).

Pre-installation and sanitization procedures as prescribed in this manual must be performed before installing the **WL500 Water Treatment System**.

Always install indoors and place the **Waterlogic WL500 Water Treatment System** on a firm, flat and stable surface.

Attach the water supply line to the 1/4" feed water inlet bulkhead fitting on the back of the unit.

Waterlogic requires the use of a water pressure regulator. Water feed pressure must be between 40-60 psi. Turn on the water supply and check for leaks.

1. Check to ensure that both the RED Power Switch and the GREEN Heater / Compressor switches are in the O=OFF position. **NOTE:** Switches have internal LED that illuminates when placed in I=ON position.
2. Connect the power cord to the back of the **Waterlogic WL500 Water Treatment System** and to a 120 Volt supply.
3. Turn the RED Power Switch to I=ON position.

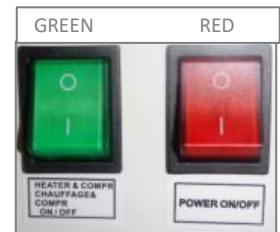

⚠ CAUTION! NEVER TURN ON HEATER BEFORE FILLING HOT TANK.

GREEN Compressor/Heater Switch must be in the O=OFF position while the Hot Tank is empty. Damage could occur within one minute and the overload (high limit) will require manual reset if heater is turned on with an empty Hot Tank.

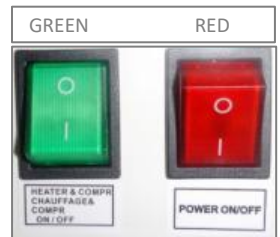

4. Prime the Cold Circuit. Holding a container under the dispensing faucet, press and hold the main dispensing button until a continuous flow of water is obtained. Once a continuous flow is obtained, release the dispensing button. Cold Tanks are now full.
5. Prime the Hot Tank. Holding a container under the dispensing faucet, press the hot button (Button 3) followed by the main dispensing button until a continuous flow of water is obtained. Once a continuous flow is obtained, release the main dispensing button. Hot Tank is now full.
6. Prime the Sparkling Circuit. Holding a container under the dispensing faucet, press the sparkling button (Button 2) followed by the main dispensing button until all water is dispensed and a continuous flow of gas is obtained. Once a continuous flow of gas is obtained, release the main dispensing button and the Sparkling Tank will regenerate itself.
7. Verify that the UV Lamp operates as expected (no alarm annunciated on the display).

⚠ WARNING! ULTRAVIOLET RADIATION. *Protect your skin and eyes against ultraviolet rays. Never look directly at an operating UV light. Always disconnect before removal.*

8. Press the cold button and dispense cold-water into the drip tray to test the alarm. Ensure that the drip tray alarm will sounds for 15 seconds, Drip Tray Fault is present on the LCD display, and the unit cuts off water supply. Empty the drip tray and wipe dry. While the drip tray is unattached from the front Panel dry the alarm sensor connectors. Carefully install drip tray to avoid damage to the metal sensor clips. Do not jam drip tray back into the unit and make sure it is properly seated.

9. Move the **Waterlogic WL500 Water Treatment System** into its final operating position. Be sure that a minimum of 2" clearance is maintained around both the sides and the back of the unit. This is important to allow proper airflow and heat exchange of refrigeration system.
10. Level unit using the adjustable feet to level if necessary. Never install on incline.
11. Turn the GREEN Heater / Compressor switch on *I=ON*. Check for fan and Compressor operation. This can be done by listening to the unit when the GREEN Heater / Compressor switch on *I=ON* and/or is turned on and/or visibly checking the fan. All tanks must be full.
12. Change the Temp Display to Ranging to monitor the cold and hot water temperatures in the tanks. After 15 minutes, the cold-water should drop approximately one degree every 1-1/2 minutes. The hot water will heat rapidly and should reach set point in 10 minutes.
13. When the unit has reached its Hot Temp Set Point, the heater will cycle off. When the unit has reached its Cold Temp Set Point Temperature, the Compressor will cycle off.
14. Once the unit is at the target temperature(s), sample the water to ensure water meets expectations and additional rinsing or adjustment is not required.
15. Regenerate the sparkling water by dispensing until a continuous flow of gas is obtained and release to let the pump inject cold-water (below 7.7°C / 46° F) into the chamber. This provides Premium Sparkling Water. Sample the sparkling water to ensure it meets expectation.
16. Check the unit for any leaks. External Leak Protection is always recommended.
17. If you choose, reconfigure the temperature display back to the original Static setting and Verify Default Program Settings (refer to Programming Instructions):



- **Cold Temp Set** = 41°F – Do not turn down as it may freeze the Sparkling Chamber.
- **Hot Temp Set** = 189°F – May need to be adjusted downward at high elevation.
- **Temp Display** = Static – Display's set point temperatures
- **UV Timer** = 3 minute - do not recommend using constant
- **F/C Set** = F -Fahrenheit Temperature Display
- **Language** = English
- **Flow Counter** = Disable by Using Filters Timer. DO NOT USE. See Filters Timer Note
- **Filters Timer** = NONE - See Filters Timer – Programming Note below
- **Filters Life** = 00 Days. Ensure it displays “Days” to confirm Filters Counter is disabled.
- **Energy Saving Sleep Mode** = On – Unit comes set with Energy Saving Sleep Mode On

Filters Timer - Programming Note:

Always enable the Filters Timer by selecting 3, 6, 9 Months or NONE. Enabling the Filters Timer will disable the Flow Counter and the Filters Life will be displayed in Days rather than Gallons.

⚠ CAUTION! NEVER ENABLE THE FLOW COUNTER. A “NO WATER SUPPLY” Fault will occur if the Flow Counter is Enabled.

FAULT CODE TROUBLESHOOTING INDEX

1. Display indicates “Change Filters”
2. Display indicates “Drip Tray Full” - Continuous Alarm will Sound
3. Display indicates “Cold Fault”
4. Display indicates “Hot Fault”
5. Display indicates “No Water Supply”
6. Display indicates “UV Fault” – Audible Alarm will sound for 15 Seconds
7. Display is Intermittent

1. Display indicates “Change Filters”

Enter Programming Mode

Menu	Options	Brief Description
Filters Timer	3 months	Timer for Filters Life set at 3 months. Displays “Change Filters” after 3 months
	6 months	Timer for Filters Life set at 6 months. Displays “Change Filters” after 6 months
	9 months	Timer for Filters Life set at 9 months. Displays “Change Filters” after 9 months
	None	Timer for Filters Life is turned off. Default is None
Filters Life	00 DAYS	Indicates amount of water flowed(gal/liters) or days elapsed since last reset Ensure Filters Timer is enabled and Filters Life indicates DAYS
Reset	OK?	Resets the Filters Life to zero. Confirm by selecting Button 3 (Hot) to Save and Exit. This resets the timer.

2. Display indicates “Drip Tray Full” - Continuous Alarm Will Sound

Action
Empty and clean the drip tray. Make sure the metal clips on the tray are clean.

3. Display indicates “Cold Fault”

Possible Reason	Solution
No power or refrigeration elements	<p>Check that the GREEN Heater and Compressor switch is on.</p> <p>Turn GREEN Heater and Compressor Switch on. <i>I = ON</i></p> 
<p>Tank has run out of cold-water.</p> <p><i>Cold Tank capacity is 4 liters for Tower and 2 liters for Counter Top.</i></p>	<p>Wait for Cold Tank to chill water to temperature prior to dispensing more cold-water.</p> <p>A greater capacity of Waterlogic Water Systems is available.</p>
Cold-Water Thermostat	Check continuity of thermostat with multimeter. Replace thermostat as required.
Refrigerant has run out	Run Compressor for at least ten minutes. If condenser is not warm then refill the refrigerant.
Compressor problem	If Compressor is not running, repair or replacement is needed.

4. Display indicates “Hot Fault”

Action
Indicates a Hot Tank sensor fault. Check to make sure the sensor is plugged in to the main PCB properly.

5. Display indicates “No Water Supply”

Possible Reason	Solution
<p>The Flow Counter is Enabled</p>	<p>A No Water Supply Fault will occur when the Flow Counter is enabled because there is no longer a flow counter device in the unit and will be looking for a signal it cannot find. To check this, enter into programming mode and scroll down to Filters Life and Enter.</p> <p>Filters Life should be displayed in Days or Months and not in Liters or Gallons. Always ensure the Filters Timer is on and set to the Default of None then save and exit (select button 4 = Extra Hot) to store this setting.</p> <p>Enabling the Filters Timer disables the Flow Counter. Always check the programming first to see if the Filters Life is shown in Days or Months instead of Gallons or Liters to validate the selection. Filters Timer should always be enabled and set and saved to NONE. Filters Life should always be displayed in time (Days or Months) instead of flow (Gallons or Liters).</p>
<p>The Sparkling Injection Pump Runs Too Long</p>	<p>A “No Water Supply Fault” will occur if the Sparkling Water Injection Pump runs for 10 minutes. This is a safety feature to prevent the Pump from being damaged. When operating properly, it should take about 1-1/2 minutes for the Pump to inject enough water to completely fill the 1 liter Sparkling Chamber. This can occur when there is not adequate supply of water to fill the Sparkling Chamber, or the pump cannot overcome the CO₂ pressure in the Sparkling Chamber, or there is not a proper ground signal from the level sensor in the Sparkling Chamber to shut off the pump once it is filled.</p> <ul style="list-style-type: none"> • The water supply is not adequate. Ensure proper water supply to the cold circuit. Remember that the WL500 Water Treatment System contains two Carbon Filters inside the Front Access Panel. The first Filters head has a valve that will shut off water supply when the Filters is removed. The water supply has been shut off or is not adequate. Always ensure there is 40-60 psi and 1.5 Liters/Min (0.4 gal/min) water supply. <ul style="list-style-type: none"> I. The internal Filters is removed and the Safety Valve in the first Filters head is stopping water supply. II. The Filters have become fouled and plugged, thereby starving the pump of make-up water. Change the Filters. III. There is not adequate water supply to the unit IV. The drip tray is full and/or a Solenoid Valve is not opening to allow water to pass. • The CO₂ gas pressure is above 45 psi, and the Booster Pump has dead-headed and cannot fill the Sparkling Chamber.

	<ul style="list-style-type: none"> • The Level Sensor has become fouled and no longer senses water ground, thereby dead-heading the booster pump on the full tank. Remove the probe and clean with file or sand paper to provide proper ground. • The pump is faulty or not producing enough pressure to fill the carbonator. Check pump to ensure output pressure is above 80 psi. If not, replace pump.
Water supply has been shut off	Turn water supply on
Too much water pressure. Recommend 40-60 psi for the WL500 Water Treatment System to operate properly.	<p>The correct input water pressure is critical to the performance of the unit to allow solenoids to open.</p> <p>Check water pressure at the inlet bulkhead with a water pressure gauge.</p> <p>Additional method of verification is to turn off water to unit and press the dispense button. Does the solenoid open without water pressure to the unit? Listen for solenoid to activate (not just the dispense button “click”)</p> <p>Adjust water pressure to 40-60 psi.</p>
The Filters have become fouled and plugged, thereby starving the booster pump of make-up water	Change Filters
The CO ₂ gas pressure is above 45 psi, and the booster pump has dead-headed and cannot fill the Sparkling Chamber.	Turn CO ₂ gas pressure to 45 psi, verify with pressure regulator.
The Sparkling Water Level Sensor has faulted and is not properly signaling the PCB to turn off the water injection pump once water fills to the probe level in the tank. No Water Supply error message will display and the pump will shut down after 10 minutes to prevent damage.	<p>Remove the probe and clean. Disconnect from power, shut off CO₂ gas to isolate Sparkling Chamber and relieve pressure in tank through the Pressure Relief Valve before removing the probe.</p> <div data-bbox="537 1570 1357 1644" style="border: 2px solid red; padding: 5px; margin: 10px 0;"> <p>Approximately ¼” of Probe Sticking out of Plastic Sleeve</p> </div> <div data-bbox="607 1650 1411 1833" style="text-align: center;">  <p>O-Ring</p> </div> <p><u>Level Probe Checks</u></p>

	<ol style="list-style-type: none"> 1. Ensure plastic sleeve is in place and properly seated. There should be approximately ¼” of probe sticking out the end. 2. Ensure O-ring is in place. 3. Tip should be clean and in good condition and the Level Probe is installed <p>⚠ DANGER! <i>If incorrectly installed, operated, or maintained, this product can cause death or sever injury. All individuals who install, operate or maintain the WL500 Water Treatment System should be trained in its proper use, warned of its dangers, and should read the entire product manual before attempting to install, operate or maintain.</i></p> <p>⚠ WARNING! <i>HIGH PRESSURE CO₂. Disconnect WL500 Water Treatment System from power. Shut off CO₂ to isolate Sparkling Chamber and relieve pressure in Tank through the Pressure Relief Valve before removing the Probe for inspection.</i></p> <p>⚠ CAUTION! <i>RIBBON CONNECTORS MUST BE FULLY ENGAGED. Ensure Ribbon Connectors are properly engaged and fully seated in Front PCB (Printed Circuit Board) to avoid intermittent / connectivity issues any time the Front Hatch Panel is accessed.</i></p>
Filters Counter is enabled and there is no signal.	Disable the Filters Timer.

6. Display indicates “UV Fault” – Audible Alarm will sound for 15 Seconds

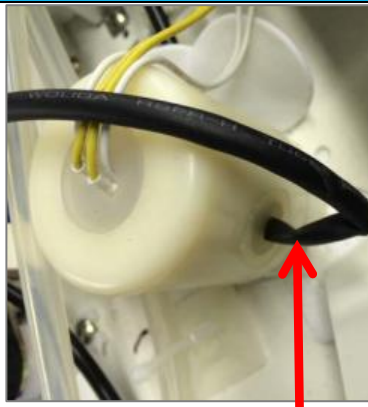
Possible Reason	Solution	
UV Lamp Failed	<p>Verify the UV Sensor is properly installed into Cold Tank UV Lamp Retaining Nut to ensure proper orientation.</p> <p><i>Always ensure the UV light is properly installed into cold tank cap to ensure proper operation.</i></p>	

7. Display is Intermittent

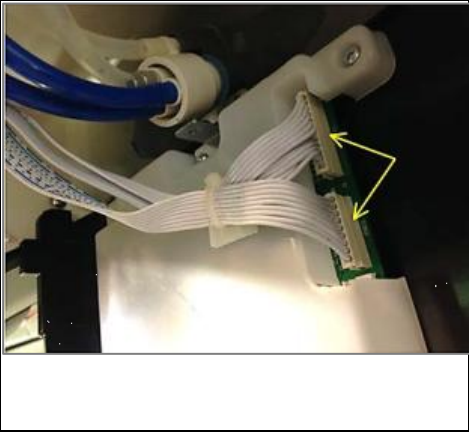
Possible Reason	Solution	
<p>Ribbon Connectors are not fully engaged</p>	<p>Verify ribbon connectors are properly engaged and fully seated in front PCB (Printed Circuit Board) to avoid intermittent / connectivity issues anytime the front Hatch Panel is accessed.</p>	

SPARKLING WATER TROUBLESHOOTING INDEX

1. Sparkling is Weak, Low Carbonation

1. Sparkling is Weak, Low Carbonation

Waterlogic WL500 Water Treatment System produces Premium Sparkling Water which is made in a batch and contains a fine, dense carbonation as compared to other “soda water” products in the market. Optimal sparkling water is generated with cold-water and food grade CO₂ set at 43 psi (3 Bar).

Waterlogic Sparkling Water is very similar to Perrier and Pellegrino Sparkling Water. Temperature of the water in the **WL500 Water Treatment System** has the largest impact on the taste and carbonation levels and the Cold Tank must be below 46°F (prefer 41°F) before injecting water into the Sparkling Chamber (carbonator) to produce proper results.

⚠ WARNING! Do not turn up CO₂ pressure beyond recommended setting of 43psi attempting to produce stronger carbonation level as the injection pump used in the carbonator will not be able to compress gas in the Sparkling Chamber and a "No Water Supply" error will result.

The temperature inside the Cold Tank can be displayed on the LCD screen by setting the temp display function to "Ranging" mode. See the programming section to adjust this setting.

Setting Customer Sparkling Water Expectation

Please ensure your customers expect a Premium Sparkling Water similar to Perrier and Pellegrino versus a Soda Water or Soda Club type of product before installing a **WL500 Water Treatment System**. The **WL500 Water Treatment System** sparkling water will not meet user's expectations if they expect a large bubble soda stream type of product.

A blind taste test using Pellegrino/Perrier is a great way to demonstrate the expectations and quality of the Waterlogic Premium Sparkling Water. Open two bottles and fill one with cold Waterlogic Sparkling Water from a freshly regenerated tank operating at optimum conditions. Recap and mark the bottles accordingly. Please ensure the bottles are sampled at the same temperature you can refrigerate them for later use and comparison. Most users will prefer the great taste of the Waterlogic Sparkling Water at a fraction of the cost of the bottled counterparts.

You may purchase a carbonation tester from a company such as Taprite to measure the level of carbonation if you wish to quantify the results and check the output of the **WL500 Water Treatment System**. The level of carbonation is very consistent as long the test conditions are repeatable and proper testing procedure is followed. User taste preferences will vary and it is critical that expectations are clear before installing a **WL500 Water Treatment System**.

Always allow the **WL500 Water Treatment System** to chill the cold-water to set point temperature (allow up to 45 minutes to chill all 4 liters of water in the unit) before sampling the sparkling water. You or your customer must "Regenerate" the Sparkling Tank by completely dispensing the initial batch of 0.8 liters of product from the Sparkling Chamber once the unit has chilled to set point of 41F. The initial batch of sparkling product will be flat because it was injected into the carbonator (Sparkling Chamber) at ambient temperature when initiating the **WL500 Water Treatment System**. Always remember that the water in the UV treated Cold Tank needs to be cold (below 46° F) to make premium good tasting sparkling water.

Do not set the cold temperature set point below 41°F or you increase the risk freezing the Sparkling Tank. The Thermistor that controls the refrigeration system is located in the well in the UV Cold Tank and does not monitor water temperature in the Sparkling Tank (carbonator). The refrigeration system chills both tanks simultaneously and is either on/off based up on feedback from the Thermistor. Frequent or continuous use of the cold still water side results in refrigeration system running and continuously chilling the sparkling product in the carbonator to the point at or below freezing. This can result in a frozen Sparkling Tank and sparkling product will not be dispensed even with proper gas supply.

ELECTRICAL SUPPLY TROUBLESHOOTING - QUICK GUIDE

1. Circuit Breaker Tripping
2. Circuit Overload
3. Short Circuit
4. Ground Fault
5. Ground Fault Circuit Interrupter (GFCI) Tripping

SAFETY PRECAUTIONS

Basic safety precautions should be followed, including the following:

⚠ DANGER! *If incorrectly installed, operated or maintained, this product can cause death or severe injury. Those who install, operate, or maintain this product should be trained in its proper use, warned of its dangers, and familiar with the tools and equipment before attempting to install, operate, or maintain the product.*

⚠ DANGER! ELECTRICAL SHOCK HAZARD. *Always unplug or isolate from power supply prior to servicing equipment to prevent electrical shock. Only authorized technicians familiar with electrical safety should attempt this advanced troubleshooting.*

Contact Waterlogic if you need any assistance or help finding an authorized service representative.

Power Supply Requirements and General Guidelines

- Ensure Power Supply is 120V 60Hz AC with a minimum of 15-amp service.
- No other equipment is to be connected to the outlet.
- Use only Waterlogic Supplied Power Cord.
- Never Use Extension Cords.

Typical Duplex Outlet is wired to carry 15 amps. Waterlogic units will draw approximately 6-7 amps at full load. However, the current can spike up when the Compressor first starts and the heater is on. Always use a minimum 15-amp service to supply a Waterlogic unit.

1. Circuit Breaker Tripping:

A circuit breaker “trips” or shuts off the electrical flow to protect the circuit from overheating and causing damage—even possibly an electrical fire.

So, before you go and flip the switch on again, take a moment to determine what the root cause is of the tripping. The three typical causes are: Overloaded Circuit, Short Circuit, Ground Fault in Outlet not equipped with Ground Fault Circuit Interrupt (GFCI) protection. See GFCI troubleshoot for outlets equipped with GFCI protection.

2. Circuit Overload

The circuit overloading is the most common reason your circuit breaker is tripping.

That means you’re running too many heavy power consuming devices at the same time on the same circuit. Ensure adequate service and that no other devices are tied to the same circuit.

3. Short Circuit

A short circuit happens when a “hot” wire (black) touches another hot wire or touches a “neutral” wire (white) in one of your outlets or devices connected to it.

When these two wires touch, a large amount of current flows, creating more heat than the circuit can handle, so it will trip the circuit breaker.

You can identify the root of a short circuit by visually checking for discoloration of components from excessive heat caused by the short. You can perform continuity or resistance checks between components to verify short circuits. Always replace any component and associated parts that have been exposed to a strain of a short circuit. All wires and connectors should be replaced to avoid failures.

4. Ground Fault

A ground fault happens when a hot wire (black) touches the ground wire (bare copper or green) on the side of a metal outlet box which is connected to the ground wire.

Just like a short circuit, you need to find the root cause and repair anything looks out of the ordinary within the circuit or equipment.

5. Ground Fault Circuit Interrupter (GFCI) Tripping:

Ground fault circuit interrupters or GFCI's are specifically designed to protect people against electric shock as it monitors the imbalance of current between the ungrounded (hot - white) supply and grounded (neutral -black) return conductor of a given circuit. A small (5 mA) difference in current or stray current will trip the GFCI. Detecting dangerous current flow and instantly shutting off power before deadly accidents occur. The sensitive circuitry inside older (pre 2006) GFCI can wear out or malfunction and usually the test button on the GFCI itself doesn't tell you there's anything wrong.

Testing GFCI:

The only reliable way to check an older GFCI is to use a circuit tester that has its own GFCI test button (available at home centers and hardware stores).

Once the GFCI circuit has been properly checked, we can attempt to pinpoint the potential problem within the unit by isolating the stray current.

Plugging the suspect unit into another GFCI outlet can indicate if stray currents are present within the unit itself.



Attempt to isolate the fault or stray current by using the following methodology:

1. Plug into properly functioning GFCI with both switches in Off (O) position.

1.1. GFCI Fault? Yes.

Identify stray current and/or inspect and replace faulty component(s) up to the Main Power Switch (Red):

- Power cord
- Power Socket
- Fuse Holder Assembly



1.2. GFCI Does Not Fault. Go to step 2.

2. Turn On Main Power (Red) Switch. Toggle to the On position (I=ON).

Switch should light to indicate power on.

- 2.1. GFCI Fault? Yes. Go to Step 3.
- 2.2. GFCI Does Not Fault. Go to Step 5.

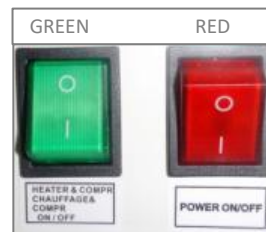

Isolate or disconnect unit from power and open Top Cover to access main Printed Circuit Board (PCB).

3. Isolate (disconnect) Main PCB

Unplug “Line” socket (red connector) with Blue and Brown wires from main power switch to PCB.

- 3.1. Reset the GFCI and cycle power back ON to check the unit with PCB isolated.
- 3.2. GFCI Does Not Fault? Stray current isolated to Power Switch.
Check and Replace Main Power Switch
- 3.3. GFCI Still Faults, go to step 4.

4. Isolate (disconnect) the UV Ballast

Unplug “BT” connector with two white wires from main PCB

- 4.1. Reset the GFCI and cycle power back ON to check the unit with UV system isolated.
- 4.2. GFCI Does Not Fault: Stray current isolated to UV.
Check and Replace faulty UV component(s)
 - UV Ballast
 - UV Lamp
 - UV Harness



4.3. GFCI Still Faults...go to step 5.

5. Turn On Heater/Compressor Power (Green) Switch to (I) Position. Switch should light to indicate power on.

- 5.1. GFCI Faults? Go to Step 6
- 5.2. GFCI Does Not Fault. Indicates problem is resolved. Ensure Full Machine Function including Compressor and heater are operational before completing work.

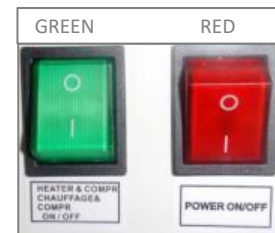

6. Isolate (disconnect) the Heater Circuit

Unplug HEATER white connector with two red wires from PCB.

- 6.1. Reset the GFCI and cycle power back on to check the unit with heater circuit isolated.



6.2. GFCI Does Not Fault:

Check and Replace faulty component(s)

- Hot Tank
- Heater Circuit Harness

6.3. GFCI Still Faults, go to step 7.

7. Isolate (disconnect) Refrigeration Circuit (Compressor and Fan).

Unplug “COMP” white connector with two black wires from PCB.

7.1. Reset the GFCI and cycle power back on to check the unit with Compressor circuit isolated.

7.2. GFCI Does Not Fault: Stray Current is in refrigeration circuit.
Go to Step 8.

8. Isolate (disconnect) Fan.

Unplug Fan from Compressor Feed Wire.

- 8.1. Reconnect the Compressor to the Main PCB
- 8.2. Disconnect Fan from Compressor Lead
Access fan connector by removing left side Panel.
- 8.3. Check the Circuit with Fan isolated.

GFCI Does Not Fault. Replace Fan.

GFCI Still Faults, Stray Current in Compressor.

8.4. Check and Replace Faulty Component(s)

- Cold Thermostat
- Compressor Starter
- Compressor



DISPENSE TROUBLESHOOTING INDEX

1. Unit is dispensing water intermittently / irregularly
2. Run-On
3. Low Flow of Water

1. Unit is dispensing water intermittently / irregularly

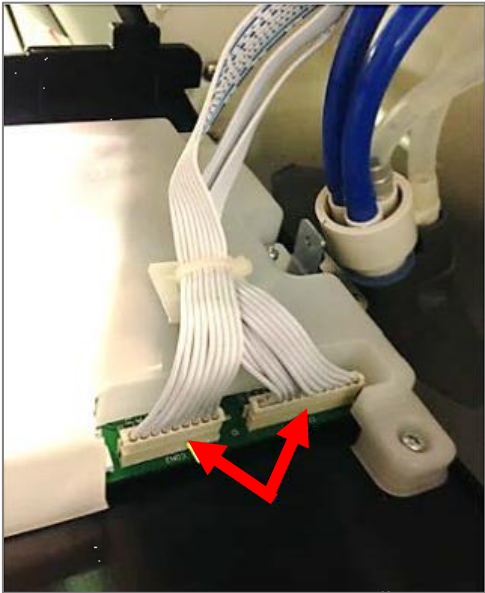
Possible Reason	Solution
<p>Ribbon Connectors are not fully engaged</p>	<p>Verify ribbon connectors are properly engaged and fully seated in front PCB (Printed Circuit Board) to avoid intermittent / connectivity issues anytime the front Hatch Panel is accessed.</p>
	
<p>Too much water pressure. Recommend 40-60 psi for the WL500 Water Treatment System to operate properly.</p>	<p>The correct input water pressure is critical to the performance of the unit to allow solenoids to open.</p> <p>Check water pressure at the inlet bulkhead with a water pressure gauge.</p> <p>Additional method of verification is to turn off water to unit and press the dispense button. Does the solenoid open without water pressure to the unit? Listen for solenoid to activate (not just the dispense button “click”)</p> <p>Adjust water pressure to 40-60 psi.</p>

2. Run On

“Run On” or “Carry On” is present in all Waterlogic pressure fed units without outlet solenoids. “Run On” is defined as the amount of water that continues to dispense out of the faucet after releasing the dispense button. Run On exists because the tanks pressurize as water is being dispensed. Every Waterlogic tank has an outlet restrictor to ensure the tanks remain full of water and water is controlled as it is released to the faucet. The inlet solenoid controls flow into the tanks. The tanks will “depressurize” once the dispense button is released the inlet solenoid closes. A small amount of water will “Run On” through the faucet as the tank depressurizes to atmospheric conditions. Typical “Run On” is 2-3 seconds. “Run On” can be reduced by installing a pressure limiting device.

The amount of inlet or supply pressure directly impacts the amount of “Run On” as quantified below.

WLCP Lab Testing of Rn On 7-31-2013				
Pressure	Pressure	Time	Flow Rate	Run On
Static PSI	Dynamic PSI	4 Liters	l/min	Seconds
68	40	61	2.9508197	3
50	30	72	2.5	2.5
32	20	92	1.956217	2
Pressure measured at inlet line to unit. Static with unit closed. Dynamic with unit dispensing cold-water.				
No Filters were installed in unit.				

3. Low Flow of Water – Rated Service Flow is 1.89 Liters (0.5 gallons) per Minute

Possible Reason	Solution
Determine Flow of Water	Rated Flow Rate is 1.89 Liters (0.5 gallons) per minute. Check flow rate by dispensing into a container to measure for one minute and measure the amount of water that was dispensed.
Feed Lines too small	Feed lines can restrict flow if run long distances from the supply. It may be necessary to increase the supply line (e.g., use 3/8” feed line vs. ¼”).
Elbows and turns in the feed line	Minimize elbows and turns in the feed line.
Filters	Filters with high pressure drop due to fouling or just by design. Change filters more frequently or go to higher micron size filter for local water conditions.
Restrictions	Follow flow path to ensure there are no undiscovered restrictions due to debris or malfunctioning valves, including the supply valve at the source.
Booster Pump	Add a booster pump to the supply line if the feed is slower than needed.