

# WL3 FX MANUAL



Waterlogic Commercial Products, LLC  
3175 Bass Pro Drive  
Grapevine, TX 76051  
(800) 288-1891 [www.waterlogicdealers.com](http://www.waterlogicdealers.com)  
Tech Portal Website: [techportal.waterlogic.com](http://techportal.waterlogic.com)

## **WL3 FX MANUAL**

Congratulations on your choice of the **Waterlogic WL3 FX Water Treatment System**. The **WL3 FX** model dispenses cold, ambient, and hot water. Every **WL3 FX Water Treatment System** includes:



**Bio-Cote Anti-Microbial Protection**



**Firewall Advanced Purification**



**Filter configuration can be optimized for all water conditions**

The **Waterlogic WL3 FX Water Treatment System** provides exceptional quality and great tasting water with every use.

## **INTRODUCTION**

Carefully read and follow all instructions to ensure proper and efficient operation of your **Waterlogic Water Treatment System**. Contact your **Authorized Waterlogic Dealer** if you have any questions.

**Waterlogic** and **Authorized Waterlogic Dealers** employ trained service personnel who are experienced in the installation, function and repair of this equipment. This publication is written for use by these qualified individuals. **Waterlogic** encourages users to learn about products, however, we believe that product knowledge and service is best obtained by consulting your **Authorized Waterlogic Dealer**.

**Waterlogic Water Treatment Systems** should be combined with selected water treatment components to create a system specifically tailored for each application by trained and qualified personnel.

Products manufactured and marketed by **Waterlogic** and its affiliates are protected by patents issued or pending in the United States and other countries.

**Waterlogic** reserves the right to change the specifications referred to in this literature at any time, without prior notice. Changes or modifications not expressly approved by **Waterlogic** could void the warranty and user's authority to operate the equipment.

## TABLE OF CONTENTS

### USER GUIDE

- Safety Alert Symbols ..... 4
- Safety Precautions ..... 4
- Features and Benefits ..... 6
- Certifications ..... 7
- Model Designations and General Specifications ..... 9
- Electrical and Shipping Specifications ..... 10
- Operating Instructions ..... 11
- Warranty ..... 12

### SERVICE GUIDE

- Service Requirements ..... 13
- LG Compressor Description ..... 14
- Hot Tank Principles of Operation ..... 15
- Hot Tank Descaling ..... 16
- Replacement Components (Consumables) ..... 18
- Countertop Drawings and Parts List ..... 19
- Tower Drawings and Parts List ..... 32
- Counter Top Flow Diagram ..... 46
- Tower Flow Diagram ..... 47
- Adjusting Cold Water Set Point ..... 48
- Electrical Schematic ..... 49

### INSTALLATION GUIDE

- Pre-Installation Procedures ..... 51
- Countertop Draining Procedure ..... 55
- Tower Draining Procedure ..... 56
- Installation Instructions ..... 57

### TROUBLESHOOTING GUIDE

- Fault Code ..... 60
- Disabling Energy Saving Mode ..... 61
- Resetting the Filter Timer ..... 62
- Hot Tank Overheat (ROR) ..... 63
- Resetting the Hot Tank Overload ..... 64
- Power Troubleshooting ..... 66
- Dispense Troubleshooting ..... 68
- Cold Water Troubleshooting ..... 77
- Hot Water Troubleshooting ..... 78

## **SAFETY ALERT SYMBOLS**

Read and follow all safety information carefully. The signal words used in this manual are selected as shown below and based on an assessment of the degree of potential injury or damage (severe or minor) and the occurrence of injury (definitely occurs or has the potential to occur) when the warning is ignored:

**⚠ DANGER!**

*Indicates a situation which, when not avoided, results in death or severe injury.*

**⚠ WARNING!**

*Indicates a situation which, when not avoided, has the potential to result in death or severe injury; and/or severe property damage.*

**⚠ CAUTION!**

*Indicates a situation which, when not avoided, results or has the potential to result in minor injury; and/or minor property damage.*

## **SAFETY PRECAUTIONS**

### **Basic safety precautions should be followed, including the following:**

Ensure all Local, State, and Federal Laws and Codes including health and safety guidelines are met when installing **Waterlogic** Equipment. Only qualified service technicians should attempt installation and service of **Waterlogic** Equipment. Always read the entire operating instructions before using the appliance and save these instructions for future use.

**⚠ DANGER!** *This product can cause death or severe injury if incorrectly operated, installed or maintained. The installation, maintenance, sanitizing and any repair must be performed by qualified persons trained by Waterlogic International or their approved distributors only. Do not remove any panel or cover to protect against electrical shock and exposure to UV radiation.*

**⚠ DANGER!** **ELECTRICAL SHOCK HAZARD.** *Always use a dedicated and properly grounded outlet. Unit should be protected by ground-fault circuit interrupter (GFCI) or residual current device (RCD) having a rated residual operating current not exceeding 30mA. Use only Waterlogic supplied power cord. Never use extension cords or power strips to connect unit. Do not use if the power supply cord is damaged. Always unplug from power supply prior to servicing.*

**⚠ WARNING!** **AUTHORIZED USE ONLY.** *This appliance is to be used for its intended purpose as described in this manual. Untrained individuals who use this manual assume the risk of any resulting property damage or personal injury. This appliance can't be used by children and persons with reduced physical, sensory, or mental capabilities or lack of experience.*

**⚠ WARNING!** **UV-C EMITTER (UV LAMP).** *This appliance contains a UV-C emitter (UV Lamp). UV-C radiation may, even in small doses, cause harm to the eyes and skin. Unintended use or damage to the housing may result in the escape of dangerous UV-C radiation. Never operate the UV-C emitter if damaged or removed from enclosure. Do not touch or look directly into the faucet.*

- ⚠ WARNING! DO NOT OPERATE IF DAMAGED.** *Unplug and isolate water supply if abnormal conditions exist. Contact Waterlogic or authorized dealer for repair, service, and installation to avoid hazards.*
- ⚠ WARNING! HOT WATER. Unit produces Hot Water in excess of 80°C (175°F).** *Water above 52°C (125°F) can cause severe burns or scalding. Keep unauthorized people and children away from the unit to avoid accidental dispensing of hot water.*
- ⚠ WARNING! CONNECT TO POTABLE WATER SUPPLY.** *This system is to be used for water only and is not intended for use where water is microbiologically unsafe or with water of unknown quality without adequate disinfection before or after the system.*
- ⚠ WARNING! TIP HAZARD.** *Dispenser could tip or fall causing serious injury. Always install unit on a firm, flat, and level surface and secure unit to cabinet, wall, or floor if needed. Never place heavy items on top of unit and never climb, stand, or hang on unit or storage cabinet to prevent injury and damage.*
- ⚠ WARNING! UNIT IS HEAVY. TWO PERSON LIFT REQUIRED.** *Transport unit empty and always use material handling equipment or two people with proper lifting technique to reduce injury risk.*
- ⚠ WARNING! STORE AND TRANSPORT UNIT EMPTY. ALWAYS SANITIZE BEFORE USE.** *The unit must be completely drained before storing to avoid stagnation and reduce microbiological contamination (potential bacterial growth). Always sanitize before use to eliminate any potential microbiological contaminants.*
- ⚠ CAUTION! INDOOR USE ONLY.** *Intended for Household Use. Never expose to direct sunlight, heat sources, or ambient air temperature above 37°C (100°F) or below 2°C (35°F). Install indoors and keep unit away from excessive humidity. Never expose to freezing temperatures. Ensure there is adequate clearance around the unit to allow refrigeration system condenser to dissipate heat. Warmer environments require more clearance around the unit. Minimum clearance around all surfaces of the machine is 2-inches. Installs where the ambient temperature exceeds 27°C (80°F), require a minimum of 4-inches clearance for proper heat dissipation and efficient operation.*
- ⚠ CAUTION! USE A WATER PRESSURE REGULATOR.** *Waterlogic will not be responsible for injury or damage caused by excessive water pressure. Input or feed pressure must be 40 psi to 60 psi. Be aware of any potential pressure surges caused by building/municipal pumping stations.*
- ⚠ CAUTION! USE UV STABILIZED SUPPLY LINES.** *Feed the unit with a potable ambient or cold water supply only. Feed water over 37°C (100°F) can damage the treatment components. Water block devices and external leak detectors are strongly recommended. Locate the unit as close to the water supply and the electrical connections as possible. Immediately isolate or close water supply valve and contact service representative if leak is noticed.*

**Contact Waterlogic for assistance or help finding an Authorized Service Representative.**

## **WL3 FX FEATURES AND BENEFITS**

### **Cold, Ambient, and Hot Water**

Counter Top and Tower Models come standard with Cold, Hot, Extra Hot, and Ambient Water Selections to meet a wide range of customer demands.

### **High Volume Storage and Water Capacity**

Tower Model has 4 liters of Cold Water Capacity and 1.5 Liters of Hot Water Capacity. Counter Top has 2 liters of Cold Water Capacity and 1.5 Liters of Hot Water Capacity.

### **BioCote® Anti-Microbial Protection**

Certain plastic, silicon, and painted surfaces surrounding the dispensing areas and drip tray are infused with an exclusive additive called BioCote®. BioCote® provides an effective barrier against microbes like bacteria and mold, which may cause odors or staining



### **Large Dispense Area with Recessed Faucet**

9.25 inch dispense height with BioCote® recessed faucet to protect from cross-contamination.

### **Leak Prevention**

**WL3 FX Water Treatment Systems** are supplied with an extra solenoid to provide redundant protection and reduces accident potential.

### **Child Safeguard**

The **WL3 FX Water Treatment System** with Hot Water requires the Hot Water selection icon be double-tapped and held to dispense Hot Water. Note there is a 2 second delay until hot water begins flowing. It will default back to the Cold selection after 3 seconds of inactivity to prevent accidental dispensing of Hot Water.

### **Firewall™**

Firewall is proprietary technology that places the UV lamp at the point of dispense. This point of dispense purification keeps the dispense nozzle free from external contamination as well as purifying the water, making the freshest water possible.

### **Energy Saver**

The **WL3 FX Water Treatment System** comes from the factory with Energy Saver active. For the WL3 FX to comply with Energy Star, the energy saver must come activated (ON) from the factory. When no buttons are pressed on the front user interface panel for 3 hours, the machine will automatically enter energy saver mode, and the heater to the hot tank will be turned OFF. When any one of the front buttons are pressed while the system is in energy saver mode, the WL3 FX will exit energy saver mode, and the hot tank will begin heating water. The hot water tank will be at set temperature within 10-minutes after exiting energy saver mode. Energy saver can be disabled by adjusting **dipswitch #2, shown on Page 59** of this manual. While the unit is in sleep mode, the “Power” LED will slowly fade then illuminate continuously, while all other LEDs will be off.

## CERTIFICATIONS

**WL3 FX Water Treatment Systems** have been tested and certified to rigorous NSF and UL Standards. We believe that performance testing and certifications validate **Waterlogic** as a world-leader in water treatment systems.

### Waterlogic WL3 FX Component Certifications Include:



Intertek

#### UL399 – Certified Drinking Water Cooler

Intertek Labs (ETL) Certified the **WL3 FX Water Treatment System** to ANSI/UL 399 Standard for Drinking Water Coolers.

#### CSA C22.2 No. 120 CSA Standard for Refrigeration

**BPA Free** - Waterlogic tests for BPA and declares that all of its products are Bisphenol-A FREE and contain no harmful BPA plastics.



#### NSF / ANSI 372 – Drinking Water System Components – Lead Content

#### CSA B483.1 - Drinking Water Treatment Systems

NSF / ANSI 372 – Drinking Water System Components for low Lead Content, and CSA B483.1 - Drinking Water Treatment Systems.

#### NSF/ANSI-55 Class A –Ultraviolet Microbiological Water Treatment Systems

Firewall™ Technology contains our latest, most innovative and patented breakthrough, “The Firewall™”, the most comprehensive UV purification system for point-of-use water treatment systems ever developed. The Waterlogic Firewall component has been tested and certified by the Water Quality Association (WQA) to NSF/ANSI-55 Class A – Ultraviolet Microbiological Water Treatment Systems



This Class A system conforms to NSF/ANSI 55 for the disinfection of microbiologically contaminated water that meets all other public health standards. The system is not intended to convert wastewater or raw sewage to drinking water. The system is intended to be installed on visually clear water. NSF/ANSI 55 defines wastewater to include human and/or animal body waste, toilet paper, and any other material intended to be deposited in a receptacle designed to receive urine and/or feces (blackwaste), and other waste materials deposited in plumbing fixtures (greywaste).



#### NSF P231/US EPA Guide Standard and Protocol for Microbiological Purifiers

The Public Health and Safety Organization establishes minimum requirements for health and sanitation characteristics of microbiological water purifiers. The requirements are based on the recommendations of the U.S. Environmental Protection Agency's Task Force Report.



**NSF/ANSI-42 – Chlorine, Taste and Odor Reduction**

**NSF/ANSI-53 – Lead, Cyst, and Asbestos Reduction**

The Public Health and Safety Organization establishes minimum requirements for materials, design, construction, and performance of drinking water treatment units that are designed to reduce specific aesthetic-related contaminants in public or private water supplies.

**Note: The WL350 contains the FT-0063-IL one-micron CBC filter (including FT-0064 filter element) certified to NSF/ANSI 42 for Chlorine, Taste, and Odor Reduction, and NSF/ANSI-53 Lead, Cyst, and Asbestos reduction. This filter must remain installed in the WL350 to maintain these certifications.**



**Energy Star Certified**

The **WL3 FX Water Treatment System**, has been tested and certified to the Energy Star, a US Environmental Protection Agency (EPA) program that helps our customers save money and protect our climate through superior energy efficiency.

**Waterlogic** is certified to ISO 9001:2015 – Quality Management Systems (certified by Intertek). ISO 9001 is the internationally accepted standard for well managed organizations that have adopted the key quality management principles to its operations to bring consistent quality products and a culture of continuous improvement.



**Safe Drinking Water Act**

**Waterlogic Water Treatment Systems** conform to the Safe Drinking Water Act (SWDA) “lead-free” amendment effective January 4, 2014.



## MODEL/PART DESIGNATIONS

BRAND NAME	DESCRIPTION	MODEL - PART NUMBER
<b>WL3 FX</b> Counter Top	<b>WL3 FX Counter Top</b> – Cold, Hot, Ambient	WL3FX-MU-HCA
	F-3FX-MU-HCA-TTL111NX-BL-WLU	
	Serial Number Prefix: NB3H349BL	
<b>WL3 FX</b> Tower	<b>WL3 FX Tower</b> – Cold, Hot, Ambient	WL3FX-FS-HCA
	F-3FX-FS-HCA-TTL111NX-BL-WLU	
	Serial Number Prefix: NB1H349BL	

## SPECIFICATIONS

<u>ITEM</u>	<u>WL3 FX</u>
Water Connection	¼" Quick Connect
Cold Water Temperature	Cold Water Temperature – Factory Set Point 5°C (41°F) Adjustable - 1.1° - 12.2°C (34° - 54° F.)
Cold Tank Size	Tower: 4 Liters (1.1 Gallons) Counter Top: 2 Liters (.53 Gallons)
Hot Water Temperature	87°C (189°F) Factory Set Point 92°C (198°F) Extra Hot Factory Set Point
Hot Water Manual Reset Overload	105°C (221°F)
Hot Tank Size	1.5 Liters (.40 Gallons)
Recommended Service Pressure	40-60 psi (275-414 kPa) – Use Pressure Regulator
Maximum Service Pressure	100 psi (689 kPa) – Use Pressure Regulator
Rated Service Flow	1.89 Liters per Minute (0.5 gallons per minute)
Environmental Temperature	2° - 37°C (35° - 100°F)
UV Lamp	Tower: 13 Watts Counter Top: 13 Watts
Heater	500 W
Refrigerant Gas	R134a, 38g, 1.34 ounces
R134a Pressures	High (230 psi), Low (90 psi)

## SHIPPING SPECIFICATIONS

<u>ITEM</u>	<u>Counter Top</u>	<u>Tower</u>
Width/Depth/Height	38.5cm x 45.2cm x 44.5cm 15.2" x 17.8" x 17.5"	38.5cm x 36.5cm x 114cm 15.2" x 14.4 x 44.9"
Weight (dry)	24 kg (52.9 pounds)	27 kg (59.5 pounds)

#Counter Top is 17.75 in. tall and may not fit between countertops and cabinets - Check installation to ensure adequate clearance.



## ELECTRICAL SPECIFICATIONS

<u>ELECTRICAL SUPPLY</u>	<u>120V/60Hz, 1PH</u>	<u>15 Amp Service</u>
<u>COMPONENT</u>	<u>POWER (approximate)</u>	<u>AMP DRAW (approximate)</u>
Heater	504	4.2 Amps
Compressor	216	1.8 Amps
UV Lamp System	18	0.15 Amps
<b>WL3 FX TOTAL</b>	<b>738</b>	<b>6.15 Amps</b>

## OPERATING INSTRUCTIONS

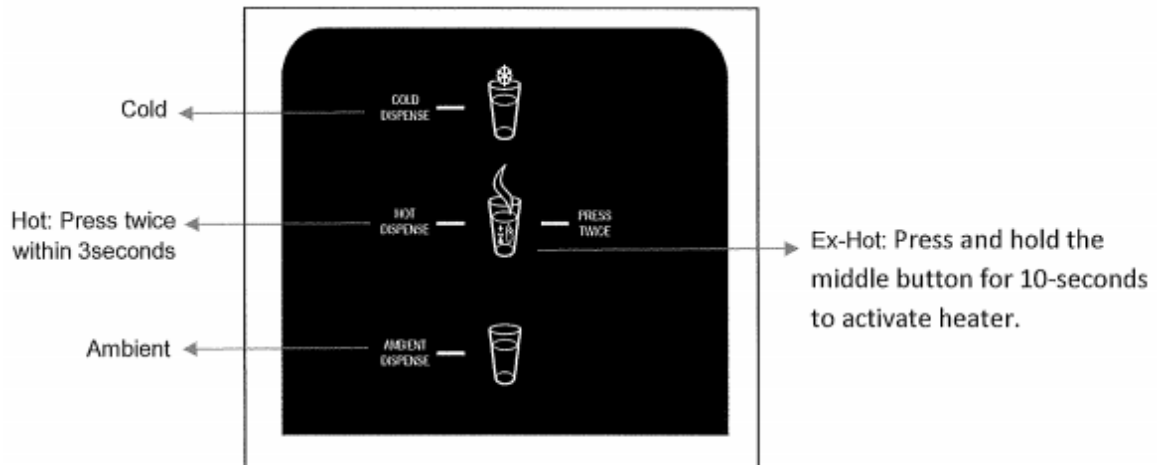

The above picture shows front user interface (UI) and control panel for the **WL3 FX Water Treatment System**.

For Cold Water: Press and Hold the “Cold Dispense” Icon.

For Hot Water: Press twice (within 3 seconds) and Hold the “Hot Dispense” Icon. LED will blink fast to indicate Hot Dispense is activated.

For Extra Hot Water: Press and Hold the “Hot Dispense” Icon for 10-seconds to activate the heater. LED will flash slowly until water is Extra Hot. When the LED stops flashing, repeat the dispense operation for Hot Water.

For Ambient Water: Press and Hold the “Ambient Dispense” Icon.

**NOTE:** If the user initiates extra hot, but then loses patience and does not want to wait any longer, then they can Press twice and Hold the “Hot Dispense” Icon to dispense hot water. This action will dispense hot water from the hot tank and will NOT cancel the Extra Hot request that was in process.

## **WATERLOGIC MANUFACTURED WATER TREATMENT SYSTEM LIMITED WARRANTY** **UNITED STATES AND CANADA ONLY**

*Waterlogic water treatment systems are guaranteed to the original purchaser to be free of defects in materials and workmanship for a period of three (3) years from the date of purchase, but in no event longer than forty-eight (48) months from the date of manufacture. Waterlogic Commercial Products, LLC (“Waterlogic”) based in the U.S.A. and its affiliated companies are not liable for any cost of removal, installation, transportation, or any other charges which may arise in connection with a warranty claim.*

*This warranty does not cover damage or wear to products caused by abnormal operating conditions, accident, abuse, misuse, unauthorized or improper alteration or repair, damage caused by or resulting from shipping or accident, damage caused by hot water, freezing, flood, fire, or acts of God. The effects from chlorine corrosion, scaling and normal wear are specifically excluded from this warranty. This warranty does not cover products used outside the countries where the unit was purchased and does not cover products that were not installed in accordance with Waterlogic printed installation and operating instructions obtained in training or from [www.waterlogic.us](http://www.waterlogic.us). Failure to follow all instructions for operation and maintenance voids the warranty. This warranty is not transferable.*

*To obtain warranty repairs or replacement, you must obtain a Return Authorization from Waterlogic. To obtain a Return Authorization, you must submit a Return Authorization form with supporting documentation to Waterlogic for evaluation. The form is available at [www.waterlogic.us](http://www.waterlogic.us). Supporting documentation must include, but is not limited to; proof of purchase, installation date, failure date, and supporting installation and maintenance data. After you submit a Return Authorization form and supporting documentation, Waterlogic will determine whether a reasonably apparent defect in materials or workmanship covered by this limited warranty exists. If Waterlogic determines the claimed defect is covered by this warranty, Waterlogic will, at its sole discretion, determine whether to correct the defect or replace the unit, free of charge to you. If Waterlogic determines that the unit should be returned for warranty service, Waterlogic will approve of return in writing and will issue a Return Authorization which you must obtain prior to shipping the product. You are responsible for the cost of freight in to Waterlogic.*

*Waterlogic and its affiliated companies hereby limit the duration of any and all implied warranties to a maximum period of three (3) years from the date of purchase including, but not limited to, the implied warranties of merchantability and fitness for a particular purpose. Some states do not allow limitations on how long an implied warranty lasts, so the above limitation may not apply to you. Consequential and incidental damages are not recoverable under this warranty. Some states do not allow the exclusion or limitation of incidental or consequential damages, so the above limitation or exclusion may not apply to you.*

*This warranty gives you specific legal rights and you may also have other rights which may vary from state to state.*

**New Warranty Policy issued by Waterlogic Commercial Products LLC, USA - January 10, 2014**

**Waterlogic Commercials Products LLC**  
3175 Bass Pro Drive  
Grapevine, TX 76051

**Tel:** (800) 288-1891  
**Website:** [waterlogic.us](http://waterlogic.us)

## **SERVICE REQUIREMENTS**

**⚠ WARNING!** *Read and understand the contents of this manual before attempting to service the WL3 FX Water Treatment System. Failure to follow the instructions in this manual could result in death, serious personal injury, or severe property damage. Only trained and qualified technicians should attempt to install, maintain, or service Waterlogic Equipment.*

1. Visually inspect all electrical and water connections for signs of wear or damage.

**⚠ DANGER!** ***HIGH VOLTAGE ELECTRICAL HAZARD.** Unplug before inspection and service.*

2. **Waterlogic** recommends changing the UV Lamp every 12 months.

**⚠ WARNING!** ***ULTRAVIOLET RADIATION.** Protect your skin and eyes against ultraviolet rays. Never look directly at an operating UV light. Disconnect before removing UV Lamp.*

**⚠ CAUTION!** ***UV LAMPS ARE HAZARDOUS.** Lamps are considered Hazardous Waste and must be disposed of accordingly. Refer to Product MSDS sheet for details.*

3. Clean the quartz sleeve that surrounds the UV lamp with a non-abrasive cloth, descaling solution, or ultrasonic bath if needed when changing UV lamps.

**⚠ CAUTION!** ***UV SYSTEM IS FRAGILE.** Never handle the UV lamp or Quartz Sleeve with bare hands. UV Lamp and quartz sleeve must be free of oils and contaminants to ensure proper operation. Use a soft non-abrasive cloth to clean.*

3. Inspect the Quartz Sleeve O-ring for wear or damage and replace as necessary.
4. Ensure there is adequate (minimum of 2") clearance around the **WL3 FX Water Treatment System** and clean the condenser grill and compressor fan to provide efficient cooling system operation.
5. Sanitize the cold tank per instructions in the pre-installation procedures.

**⚠ WARNING!** ***SANITIZER MAY CONTAIN HAZARDOUS CHEMICALS.** Use of proper personal protective equipment such as rubber gloves and eye protection is required.*

6. Clean and sanitize external surfaces of the **WL3 FX Water Treatment System**. Use soap and water or chemicals that are compatible with ABS plastic and will not damage or degrade the product surfaces.
7. Remove and clean the Faucet. Replace as needed.
8. Descale Hot Tank Annually, or as needed.

## LG COMPRESSOR

\*Parts List in this manual updated to reflect these changes.

**LG Compressor 120V R134A 1/8HP CSB035LJCM with external start/run capacitor.**

### LG Compressor with External Start/Run Capacitor



LG CSB035 LJCM Compressor

**External Capacitor**

### **LG CSB035LJCM 120V R134A 1/8HP Compressor Repair Parts**

Part # CO-0017-L00-00 LG Compressor 120V CSB035LJCM-PTC Relay  
 Part # CO-0018-L00-00 LG Compressor 120V CSB035LJCM-Overload Protector  
 Part # CO-0019-L00-00 LG Compressor 120V CSB035LJCM-Capacitor

## HOT TANK PRINCIPLES OF OPERATION

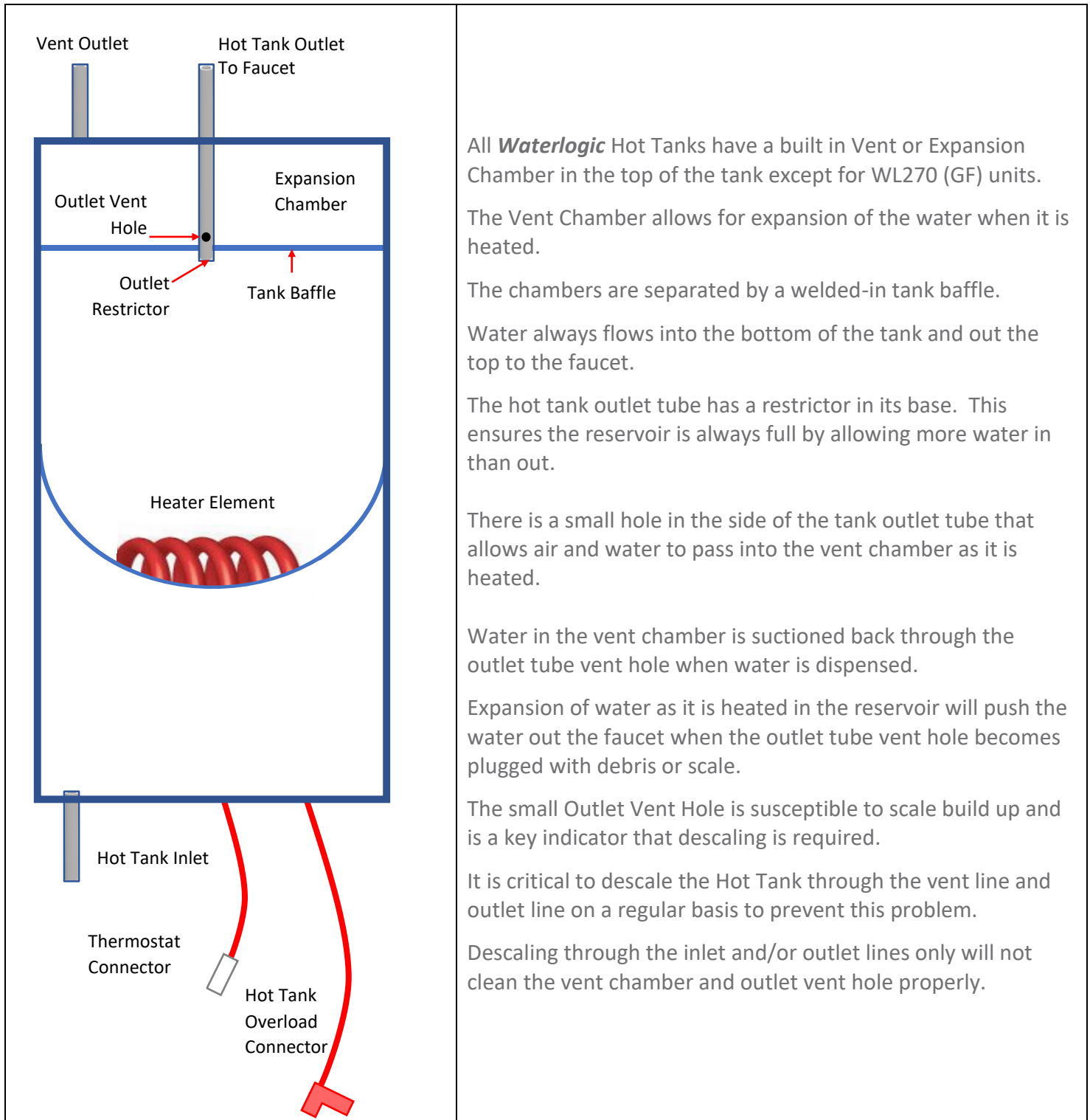

All **Waterlogic** Hot Tanks have a built in Vent or Expansion Chamber in the top of the tank except for WL270 (GF) units.

The Vent Chamber allows for expansion of the water when it is heated.

The chambers are separated by a welded-in tank baffle.

Water always flows into the bottom of the tank and out the top to the faucet.

The hot tank outlet tube has a restrictor in its base. This ensures the reservoir is always full by allowing more water in than out.

There is a small hole in the side of the tank outlet tube that allows air and water to pass into the vent chamber as it is heated.

Water in the vent chamber is suctioned back through the outlet tube vent hole when water is dispensed.

Expansion of water as it is heated in the reservoir will push the water out the faucet when the outlet tube vent hole becomes plugged with debris or scale.

The small Outlet Vent Hole is susceptible to scale build up and is a key indicator that descaling is required.

It is critical to descale the Hot Tank through the vent line and outlet line on a regular basis to prevent this problem.

Descaling through the inlet and/or outlet lines only will not clean the vent chamber and outlet vent hole properly.



## **HOT TANK DESCALING INSTRUCTIONS**

The Hot Tank requires removal of mineral deposits (descaling) on a regular basis. Typically descaling should take place every 6 to 12 months to preserve the long-term health of your unit.

Use non-toxic cleaner such as ScaleKleen, DEZCAL, 20% Citric Acid Solution, or Undiluted Vinegar Solution to remove mineral deposits as directed by the manufacturer depending upon filtration and local water conditions.

Descaling is an important process that removes calcium deposits, or scale, that can build up inside a tank over time. Calcium and scale is non-toxic but left unattended will hinder your **WL3 FX Water Treatment System's** performance.

**⚠️ WARNING!** **PERSONAL PROTECTIVE EQUIPMENT REQUIRED.** *Always ensure proper ventilation and use rubber or nitrile gloves and eye protection when using chemicals. Refer to Material Safety Data Sheet for specific requirements of each product.*

**⚠️ CAUTION!** **STAINLESS STEEL TANK DESCALING.**  
*The Hot Tank is made from stainless steel. Ensure descaling solution is compatible with stainless and always flush the **WL3 FX Water Treatment System** completely. Dispose in an environmentally safe manner.*

### **Materials Needed:**

- Personal Protective Equipment. Rubber or Nitrile Safety Gloves and Protective Eyewear
  - Phillips Screwdriver
  - Temperature Gauge
  - Water Pitcher or Container to collect water from the faucet
  - 5-gallon container or drain basin
  - Citric Acid Based Cleaner
  - ¼" Plastic Tubing, at least 4 feet in length, and assorted ¼" quick connect fittings
  - Sanitizing Cartridge (or an empty in-line filter housing)
  - Food Coloring
1. Put descaling solution per directions and 3 drops of food coloring into the descaling cartridge.
  2. Connect descaling cartridge to the inlet water supply and connect to inlet bulkhead fitting on the back of the **WL3 FX Water Treatment System**. Turn on Water Supply.
  3. Select Hot Water and depress the Main Dispensing Button on the Front Control Panel until descaling solution (colored water) comes out of the faucet. Container and drain basin will be required to catch water from the faucet.

4. Turn off water supply and remove sanitizing cartridge from inlet water supply. Reconnect water supply to inlet fitting.
5. Allow descaling solution to remain in the Hot Tank for 15 minutes (length of time may vary depending on water conditions).
6. Place a pitcher, catch basin or other container under the faucet of the **WL3 FX Water Treatment System**.
7. Flush the Hot Tank until water runs clear.
8. Once clear Water dispenses from the faucet the Hot Tank has been descaled. Always ensure the **WL3 FX Water Treatment System** is performing to the customer's satisfaction.

**⚠ WARNING! HOT WATER HAZARD.** The **WL3 FX Water Treatment System** Produces Hot Water and Steam. Always use insulated and chemically compatible containers and let **WL3 FX Water Treatment System** cool down before draining the hot tank to avoid injury.

**⚠ CAUTION! MUST REPLACE HOT TANK EVERY 3-5 YEARS DEPENDING ON USAGE**  
The Hot Tank and its controls must be replaced a minimum of every three to five years depending on usage to ensure efficient and dependable operation.

**⚠ WARNING! REINSTALL ALL PANELS AND COVERS.** Always reinstall all Panels, protective covers, and fasteners after servicing equipment. Failure to do so could result in severe personal injury and will void the certifications and warranty of the equipment.

## REPLACEMENT COMPONENTS (CONSUMABLES)

Component	WLCP Part No.	Frequency of Replacement
UV Light, 13Watt Assembly <b>Counter Top and Tower</b>	CT-2090-IA0-00	Every 12 months, or as required
Hot Tank 1.5 Liter (.40 Gallons) 87°C (189°F) - <b>Counter Top and Tower</b>	HT-3024	Replace every 3-5 years depending on usage
GAC Filter - 10" Carbon Activated Inline Filter – <i>Optional</i> <i>*Filter Element PN FT-0038-WLT</i>	FT-0035	Every 6-months or as required. Local water conditions will determine proper filter type and maintenance schedule. FT-0035-IL-WLT
Carbon Block - 10" CBC 1 Micron Lead and Cyst Reduction Inline Filter – <i>Optional</i> <i>*Filter Element PN FT-0064-WLT</i>	FT-0063	Every 6-months or as required. Local water conditions will determine proper filter type and maintenance schedule. FT-0063-IL-WLT
Sediment Filter - 10" Sediment 20 Micron Inline Filter – <i>Optional</i> <i>*Filter Element PN FT-0055-WLT</i>	FT-0053	Every 6-months or as required. Local water conditions will determine proper filter type and maintenance schedule. FT-0053-IL-WLT

**⚠ CAUTION!** Use only Waterlogic Replacement parts that can be obtained from *Waterlogic* or an *Authorized Waterlogic Dealer*, failure to do so will void the Warranty.

See Installation and Service Manual for additional information.

### Hot Tank Service

Hot Tanks (with controls) must be replaced at least every 3-5 years depending on usage. Descaling hot tank may be required on a regular basis depending upon filtration and local water conditions. See Installation and Service Manual for further details.

### Surface Cleaning

Clean on a regular basis with damp lint free cloth. Never use harsh chemicals (alcohol or acid based) or abrasive agents on any part of the product to avoid damage. A mild cleaner such as Simple Green or equivalent is recommended.

## DISPOSAL

### End of Life

At the **end of this product's life**, ensure that it is disposed of in an environmentally friendly manner which is fully compliant **with all Federal/State/Local Requirements and Guidelines**. Do not dispose of this appliance with normal household or business waste.

## WL3 FX COUNTER TOP DRAWING AND PARTS LIST

Yellow = Consumables

Green = Recommended spare parts

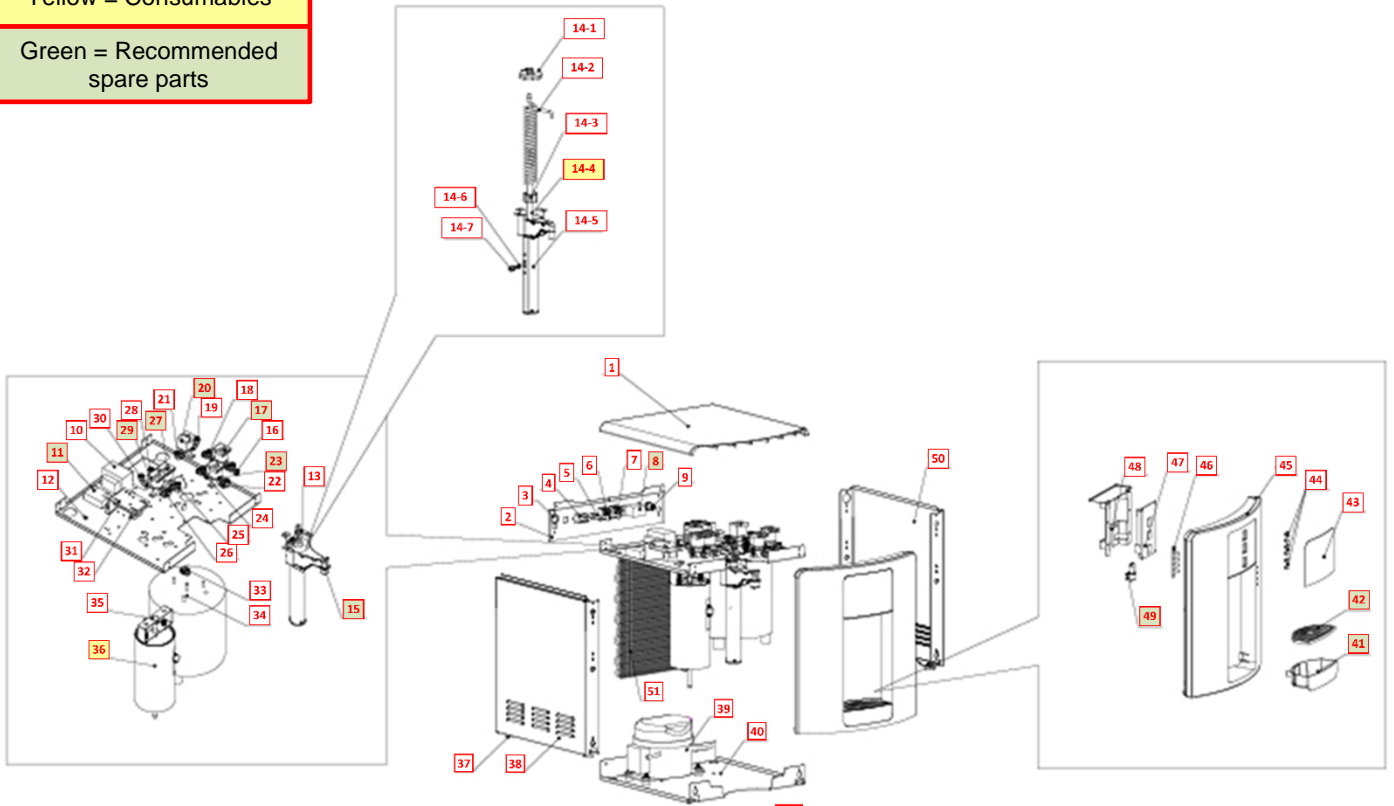

### Wetted Parts Drawing

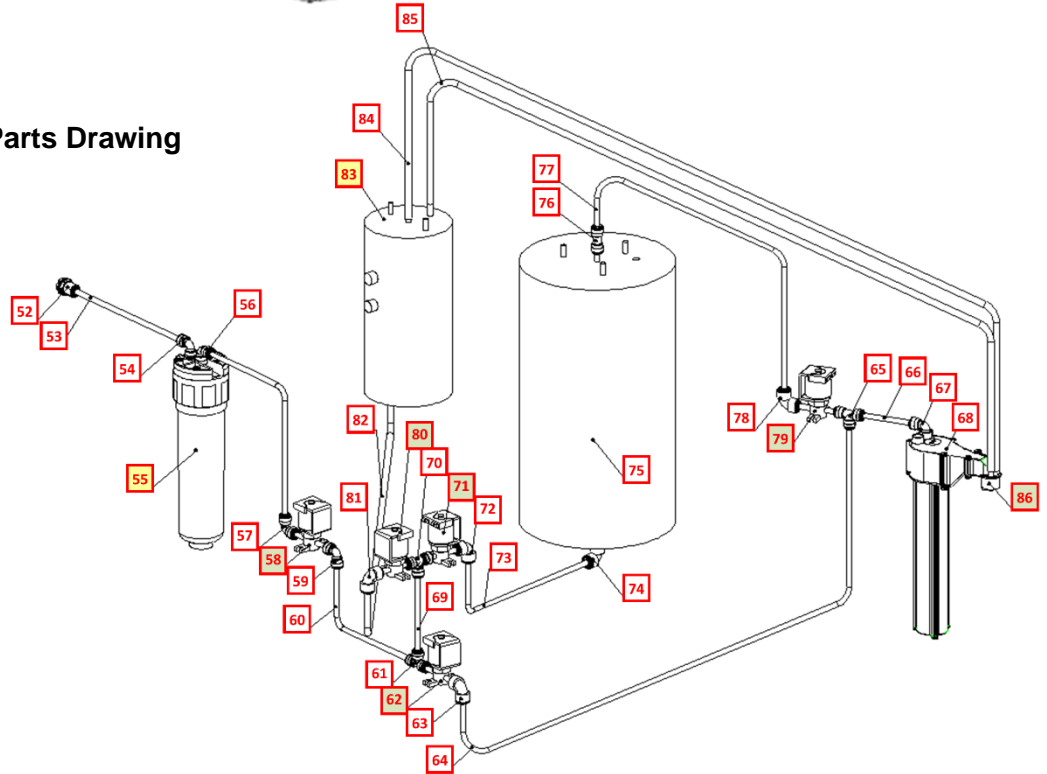







No.	WLCP Part No.	Part No.	Description	Photo
1	N/A	PL-0056-L00-BL	WL3 Countertop Top Cover - Black	
2	N/A	ST-0072-L00-BL	WL3 Countertop back panel (add 2 holes for Culligan filter head)-Black	
3	N/A	PL-1293	Rubber O-ring for GF Side Panel Drain Hole	
4	EL-0061-L00-00	EL-0061-L00-00	Socket for Plug Connection V0 class	
5	10-3014	EL-5053	Fuse Holder & Fuse 110V/15A with only one wire chiller3 & lo	
6	12-5600	EL-5019-A	Power Switch (Red)-No back lights	
7	10-3009	EL-5005	Switch - Heater/Compressor (Green)	
8	19-1069	CT-2070-A	Cold Tank Thermostat	

9	10-3067	PU-4028	JG Bulkhead Union 1/4"x1/4"	
10	EL-0016-L00-00	EL-0016-L00-00	Power Transformer 120v/2A for Cube	
11	12-8315	EN-0008-L01-00	15w Electronic Ballast 120V 60Hz v3	
12	N/A	ST-0064-L00-00	WL3 Countertop HCA upper base panel	
13	PU-4008	PU-4008	JG Reducing Elbow 1/4"	
14	N/A	N/A	Firewall Assembly	
14.1	N/A	CT-2078-B	WL-4 Firewall UV Fixing	
14.2	FW-0008-L00-00	FW-0008-L00-00	WL Cube Spiral Quartz Sleeve	

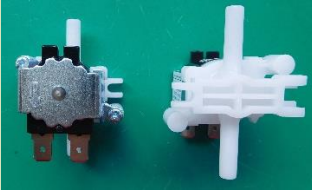
14.3	N/A	FW-0021-L00-00	FW4 Spiral Buffer Rubber	
14.4	10-8075	CT-2090-IA0-00	13W LTFW XTM UV Lamp - 300	
14.5	N/A	FW-0046-I00-00	WL3 Micro FW AL housing with Bracket (mirror/no gauze) – India	
14.6	AK-0064	N/A	UV Sensor With Wire	
14.7				
15	PL-1382	PL-1382	WL3 Hot Water Faucet	
16	PU-4011	PU-4011	JG Equal Tee Connector 1/4"	
17	PU-0017-I00-00	PU-0017-I00-00	MS DC Solenoid Valve SWV24-01	

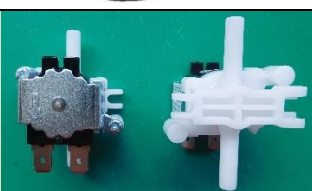







18	PU-4011	PU-4011	JG Equal Tee 1/4"	
19	PU-4008	PU-4008	JG Equal Elbow 1/4"	
20	PU-0017-I00-00	PU-0017-I00-00	MS DC Solenoid Valve SWV24-01	
21	PU-4008	PU-4008	JG Equal Elbow 1/4"	
22	PU-4008	PU-4008	JG Equal Elbow 1/4"	
23	PU-0017-I00-00	PU-0017-I00-00	MS DC Solenoid Valve SWV24-01	
24	PU-4011	PU-4011	JG Equal Tee 1/4"	
25	PU-4008	PU-4008	JG Equal Elbow 1/4"	

26	PU-4007	PU-4007	JG Reducing Elbow 5/16" - 1/4"	
27	PU-0017-I00-00	PU-0017-I00-00	MS DC Solenoid Valve SWV24-01	
28	PU-4008	PU-4008	JG Equal Elbow 1/4"	
29	PU-0017-I00-00	PU-0017-I00-00	MS DC Solenoid Valve SWV24-01	
30	PU-4008	PU-4008	JG Equal Elbow 1/4"	
31	N/A	ST-8287	3min UV Timer PCB Fixing Bracket	
32	N/A	EN-0134-L00-00	WL3 NEW HCA MAIN PCB	
33	PU-4008	PU-4008	JG Equal Elbow 1/4"	

34	N/A	CT-0002-I00-00	3FW Countertop 2L Cold Tank	
35	12-8006	ST-8120	Hot Tank Fixing Bracket 400mm for 1.5L	
36	10-4029	HT-3024	Hot Tank (Pipe) 120V/500W - UVF2 1.5L	
36.1	10-3030	HT-3002	Hot Tank Thermistor	
37	10-3083	ST-8016	Unit Control Rubber Feet WL3000	
38	N/A	ST-0328-L00-00	WL3 Countertop Mini Left Side Panel	
39	CO-0020-L00-00	CO-0020-L00-00	LG Compressor 120V R134A-CSB035LJCM	
40	N/A	ST-8036	Mini Down Base for 650 & Chiller white universal as ST-8012	

41	N/A	PL-0049-L00-BL-WLG	WL3 lower drip tray body for WLG black - WL logo - w.BioCote	
42	PL-0029-L00-BL	PL-0029-L00-BL	WL3 Drip Tray Grill - Black - with Biocote	
43	N/A	LP-0535-L00-00	WL3 HCA Countertop UI Label	
44	N/A	PL-1379	WL3 Button Cover for LED Diffuser	
45	N/A	PL-0292-L00-BL	WL3 Countertop Front Upper Panel - Black with FW Logo	
46	EN-6139	EN-6139	WL3 LED PCB	
47	N/A	EN-0135-L00-00	WL3 New HCA UI PCB	

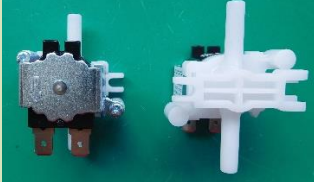
48	N/A	ST-0331-L00-00	WL3 HCA UI PCB Cover	
49	PL-1382	PL-1382	WL3 Hot Water Faucet	
50	N/A	ST-0329-L00-00	WL3 Countertop Right Side Panel	
51	N/A	CO-0047-L00-00	WL3 Countertop Condenser	
52	PU-4028	PU-4028	JG Bulkhead Union 1/4"x1/4"	
53	PU-4031	PU-4031	1/4" PE Pipe	
54	PU-4008	PU-4008	JG Equal Elbow 1/4"	
55	FT-0053 FT-0035 FT-0063	FT-0053 FT-0035 FT-0063	WL Inline Filter	

56	PU-4008	PU-4008	JG Equal Elbow 1/4"	
57	PU-4008	PU-4008	JG Equal Elbow 1/4"	
58	PU-0017-I00-00	PU-0017-I00-00	MS DC Solenoid Valve SWV24-01	
59	PU-4008	PU-4008	JG Equal Elbow 1/4"	
60	PU-4031	PU-4031	1/4" PE Pipe	
61	PU-4011	PU-4011	JG Equal Tee 1/4"	
62	PU-0017-I00-00	PU-0017-I00-00	MS DC Solenoid Valve SWV24-01	
63	PU-4008	PU-4008	JG Equal Elbow 1/4"	

64	PU-4031	PU-4031	1/4" PE Pipe	
65	PU-4011	PU-4011	JG Equal Tee 1/4"	
66	PU-4031	PU-4031	1/4" PE Pipe	
67	PU-4008	PU-4008	JG Equal Elbow 1/4"	
68	N/A	N/A	Firewall Assembly	
69	PU-4031	PU-4031	1/4" PE Pipe	
70	PU-4011	PU-4011	JG Equal Tee 1/4"	
71	PU-0017-I00-00	PU-0017-I00-00	MS DC Solenoid Valve SWV24-01	



72	PU-4008	PU-4008	JG Equal Elbow 1/4"	
73	PU-4031	PU-4031	1/4" PE Pipe	
74	PU-4008	PU-4008	JG Equal Elbow 1/4"	
75	CT-0002-I00-00	CT-0002-I00-00	Cold Tank Assembly (4L, No UV holder, No sub-tank)- FW	
76	PU-4010	PU-4010	JG Equal Straight Connector 1/4"	
77	PU-4031	PU-4031	1/4" PE Pipe	
78	PU-4008	PU-4008	JG Equal Elbow 1/4"	
79	PU-0017-I00-00	PU-0017-I00-00	MS DC Solenoid Valve SWV24-01	

80	PU-0017-I00-00	PU-0017-I00-00	MS DC Solenoid Valve SWV24-01	
81	PU-4007	PU-4007	JG Reducing Elbow 5/16-1/4"	
82	PU-4014	PU-4014	JG LLDPE Tube - Blue 8mm	
83	10-4029	HT-3024	Hot Tank	
84	PL-4064-L00-00	PL-4064-L00-00	Silicone Pipe 5/16" Non-WRAS	
85	PL-4064-L00-00	PL-4064-L00-00	Silicone Pipe 5/16" Non-WRAS	
86	PL-1382	PL-1382	WL3 Hot Water Faucet	

## WL3 FX TOWER DRAWING AND PARTS LIST

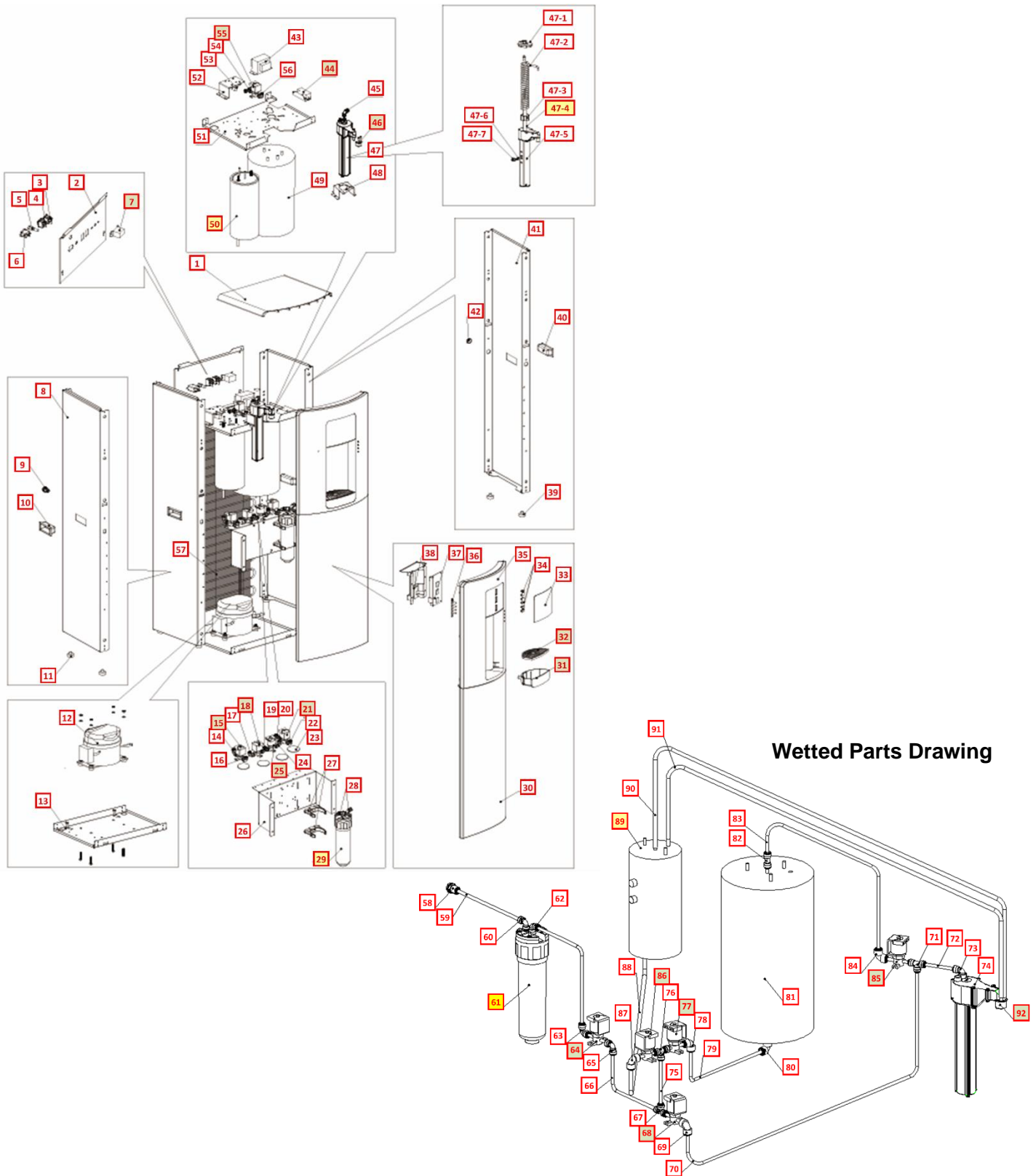

No	WLCP Part No.	Part No.	Description	
1	PL-1381	PL-1381	WL3 Top Cover Black	
2	12-1622	ST-8028	650 FS back Panel Black	
3	10-3009	EL-5005	Switch - Heater/Compressor (Green)	
4	12-5600	EL-5019-A	Power Switch (Red)-No back lights	
5	10-3014	EL-5053	Fuse Holder & Fuse 110V/15A with only one wire chiller3 & lo	
6	EL-0061-L00-00	EL-0061-L00-00	Socket for Plug Connection V0 class	
7	12-1101	CT-2016	Cold Tank Thermostat	
8	10-4002	ST-8225	WL950,650,750 Universal Left&Right Side panel Black	

9	PU-4028	PU-4028	JG Bulkhead Union 1/4"x1/4"	
10	10-4004	PL-1120	Plastic Handle Black	
11	10-3083	ST-8016	Unit Control Rubber Feet WL3000	
12	CO-0020-L00-00	CO-0020-L00-00	LG Compressor 120V R134A-CSB035LJCM	
13	12-1602	ST-8035	Down Base White - WL650 universal as ST-8011	
14	PU-4008	PU-4008	JG Equal Elbow 1/4"	
15	PU-0017-100-00	PU-0017-100-00	MS DC Solenoid Valve SWV24-01	
16	PU-4008	PU-4008	JG Equal Elbow 1/4"	

17	PU-4007	PU-4007	JG Reducing Elbow 5/16"x1/4"	
18	PU-0017-100-00	PU-0017-100-00	MS DC Solenoid Valve SWV24-01	
19	PU-4011	PU-4011	JG Equal Tee 1/4"	
20	PU-4011	PU-4011	JG Equal Tee 1/4"	
21	PU-0017-100-00	PU-0017-100-00	MS DC Solenoid Valve SWV24-01	
22	PU-4008	PU-4008	JG Equal Elbow 1/4"	
23	CU-0001	CU-0001	Cushion for solenoid valve	
24	PU-4008	PU-4008	JG Equal Elbow 1/4"	







25	PU-0017-100-00	PU-0017-100-00	MS DC Solenoid Valve SWV24-01	
26	19-1016	ST-8206CN	Universal FS Filter Bracket for 950,650,850	
27	20-1010	PU-4161	2.8" Filter Clip	
28	PU-4008	PU-4008	JG Equal Elbow 1/4"	
29	FT-0053 FT-0035 FT-0063	FT-0053 FT-0035 FT-0063	WL Inline Filter	
30	PL-0020-L00-BL	PL-0020-L00-BL	WL3 front down panel Black-No logo printing	
31	N/A	PL-0049-L00-BL-WLG	WL3 lower drip tray body for WLG black - WL logo - w.BioCote	
32	PL-0029-L00-BL	PL-0029-L00-BL	WL3 Drip tray grill - Black-Biocote added.	

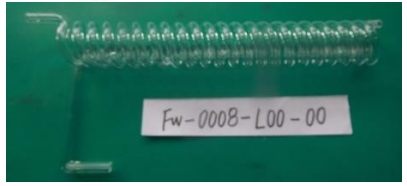
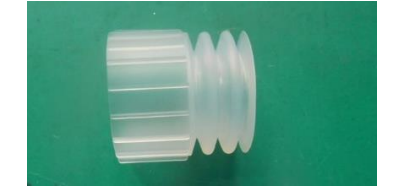
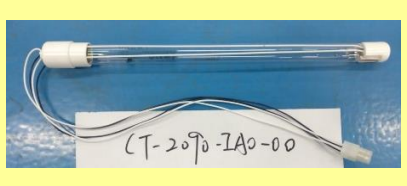

33	N/A	LP-0535-L00-00	WL3 HCA Countertop UI Label	
34	N/A	PL-1379	WL3 Front Upper Button Cover	
35	PL-0017-L00-BL	PL-0017-L00-BL	WL3 Front upper panel Black – FW Logo	
36	EN-6139	EN-6139	WL3 LED PCB	
37	N/A	EN-0135-L00-00	WL3 NEW HCA UI PCB	
38	N/A	ST-0331-L00-00	WL3 HCA UI PCB Cover	
39	10-3083	ST-8016	Unit Control Rubber Feet WL3000	
40	10-4004	PL-1120	Plastic Handle Black	

41	10-4002	ST-8225	WL950,650,750 Universal Left&Right Side panel Black	
42	N/A	PL-1293	Rubber O-ring for GF Side Panel Drain Hole	
43	EL-0016-L00	EL-0016-L00-00	Power Transformer 120V/2A	
44	EN-0008-LA1-00	EN-0008-LA1-00	13W/15W Electronic Ballast 120V 60Hz	
45	PU-4008	PU-4008	JG Equal Elbow 1/4"	
46	PL-1382	PL-1382	Hot Faucet	
47	N/A	N/A	Firewall Assy	
47.1	N/A	CT-2078-B	WL-4 Firewall UV Fixing	

47.2	FW-0008-L00-00	FW-0008-L00-00	WL Cube Spiral Quartz Sleeve	
47.3	N/A	FW-0021-L00-00	FW4 Spiral Buffer Rubber	
47.4	10-8075	CT-2090-IA0-00	13W LTFW XTM UV Lamp – 300	
47.5	N/A	FW-0032-I00-00	WL3 FS Firewall AL Mark VI (Mirror/No Gauze) with Bracket IND	
47.6	AK-0064	N/A	UV Sensor with Wire	
47.7				
48	N/A	FW-0046-L00-00	WL4 Firewall – AL Faucet Bracket	
49	CT-2017-A	CT-2017-A	UV Cold Tank Assy 4L – No UV Holder, no sub-tank) - FW	

50	10-4029	HT-3024	Hot Tank	
50.1	10-3030	HT-3002	Hot Tank Thermistor	
51	N/A	ST-0034-L00-00	Upper base HCA	
52	N/A	ST-8287	3minutes UV Timer PCB Fixing Bracket	
53	N/A	EN-0134-L00-00	WL3 NEW HCA MAIN PCB	
54	PU-4011	PU-4011	JG Equal Tee 1/4"	
55	PU-0017-100-00	PU-0017-100-00	MS DC Solenoid Valve SWV24-01	
56	PU-4008	PU-4008	JG Equal Elbow 1/4"	

57	12-1000	CO-9007	Wire Condenser WL650FS	
58	PU-4028	PU-4028	JG Bulkhead Union 1/4"x1/4"	
59	PU-4031	PU-4031	1/4" PE Pipe	
60	PU-4008	PU-4008	JG Equal Elbow 1/4"	
61	FT-0053 FT-0035 FT-0063	FT-0053 FT-0035 FT-0063	WL Inline Filter	
62	PU-4008	PU-4008	JG Equal Elbow 1/4"	
63	PU-4008	PU-4008	JG Equal Elbow 1/4"	
64	PU-0017-100-00	PU-0017-100-00	MS DC Solenoid Valve SWV24-01	

65	PU-4008	PU-4008	JG Equal Elbow 1/4"	
66	PU-4031	PU-4031	1/4" PE Pipe	
67	PU-4011	PU-4011	JG Equal Tee 1/4"	
68	PU-0017-100-00	PU-0017-100-00	MS DC Solenoid Valve SWV24-01	
69	PU-4008	PU-4008	JG Equal Elbow 1/4"	
70	PU-4031	PU-4031	1/4" PE Pipe	
71	PU-4011	PU-4011	JG Equal Tee 1/4"	
72	PU-4031	PU-4031	1/4" PE Pipe	



73	PU-4008	PU-4008	JG Equal Elbow 1/4"	
74	N/A	N/A	Firewall Assembly	
75	PU-4031	PU-4031	1/4" PE Pipe	
76	PU-4011	PU-4011	JG Equal Tee 1/4"	
77	PU-0017-100-00	PU-0017-100-00	MS DC Solenoid Valve SWV24-01	
78	PU-4008	PU-4008	JG Equal Elbow 1/4"	
79	PU-4031	PU-4031	1/4" PE Pipe	
80	PU-4008	PU-4008	JG Equal Elbow 1/4"	



81	CT-2017-A	CT-2017-A	Cold Tank Assembly (4L, No UV holder, No sub-tank)- FW	
82	PU-4010	PU-4010	JG Equal Straight Connector 1/4"	
83	PU-4031	PU-4031	1/4" PE Pipe	
84	PU-4008	PU-4008	JG Equal Elbow 1/4"	
85	PU-0017-100-00	PU-0017-100-00	MS DC Solenoid Valve SWV24-01	
86	PU-0017-100-00	PU-0017-100-00	MS DC Solenoid Valve SWV24-01	
87	PU-4007	PU-4007	JG Reducing Elbow 5/16-1/4"	
88	PU-4014	PU-4014	JG LLDPE Tube - Blue 8mm	

89	10-4029	HT-3024	Hot Tank	
90	PL-4064-L00-00	PL-4064-L00-00	Silicone Pipe 5/16" Non-WRAS	
91	PL-4064-L00-00	PL-4064-L00-00	Silicone Pipe 5/16" Non-WRAS	
92	PL-1382	PL-1382	WL3 Hot Water Faucet	



## WL3 FX TOWER WATER FLOW DIAGRAM

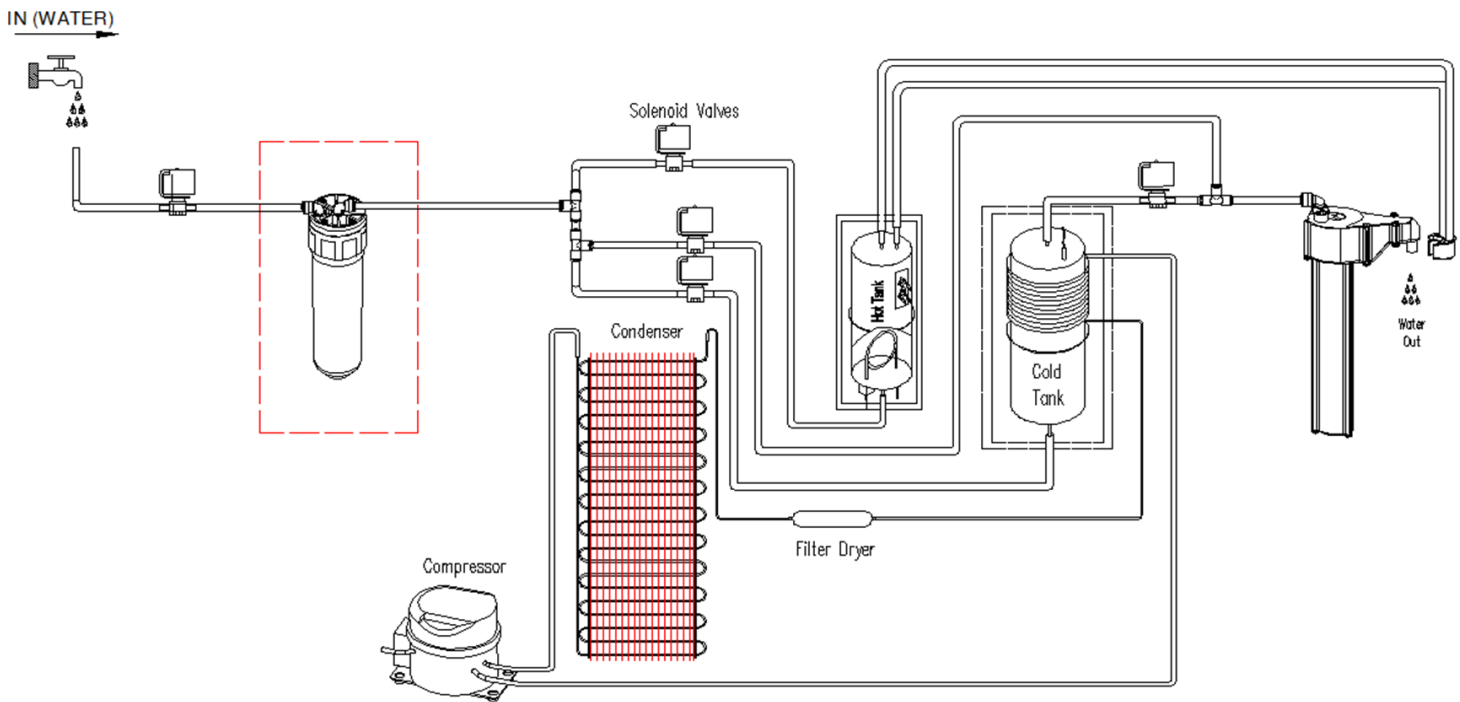

## ADJUSTING COLD SET POINT

Cold Water Temperature – Factory Set Point is 41°F (5°C) and can be adjusted to 34°F - 54°F (1.1°C to 12.2°C)

The cold set point can be adjusted by accessing the cold thermostat adjustment screw under the decal at the rear of the unit.



Remove the red portion of the Cold Tank Temperature label to access the adjustment screw.

The factory set point is ~41°F and is indicated by the dot on sheet metal.



Turning the adjustment screw clockwise to lower the set point temperature.

Do not adjust past the “Max Cold” position at 3:00 position to avoid freezing the cold tank.



Turning the adjustment screw counter-clockwise to raise the set point temperature.

## WL3 FX ELECTRICAL DIAGRAM

**⚠ DANGER!** HIGH VOLTAGE ELECTRICAL HAZARD. PCB (Printed Circuit Board) contains High Voltage. Only trained and qualified technicians should attempt live testing.

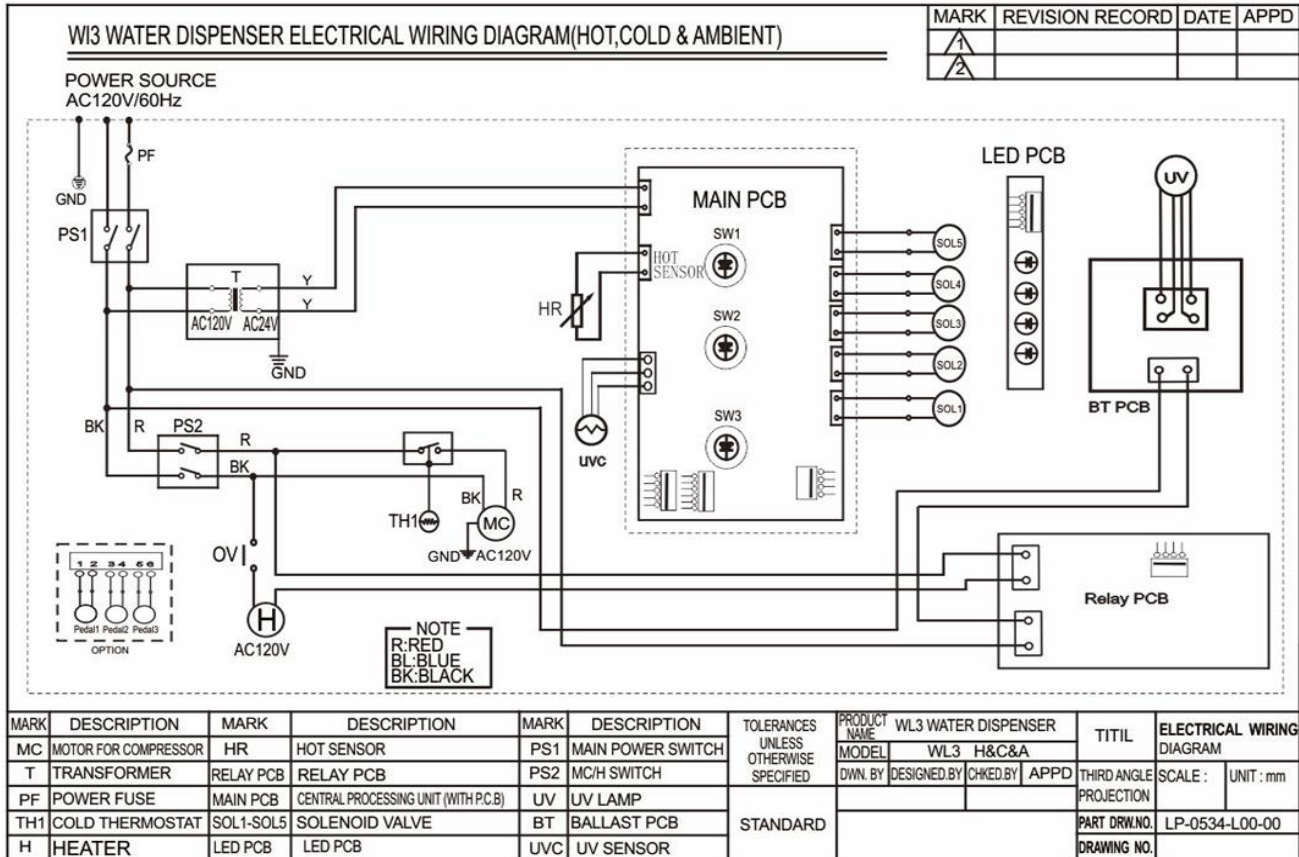



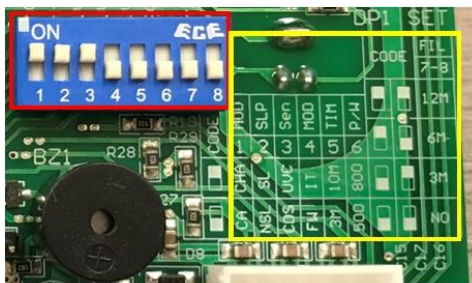
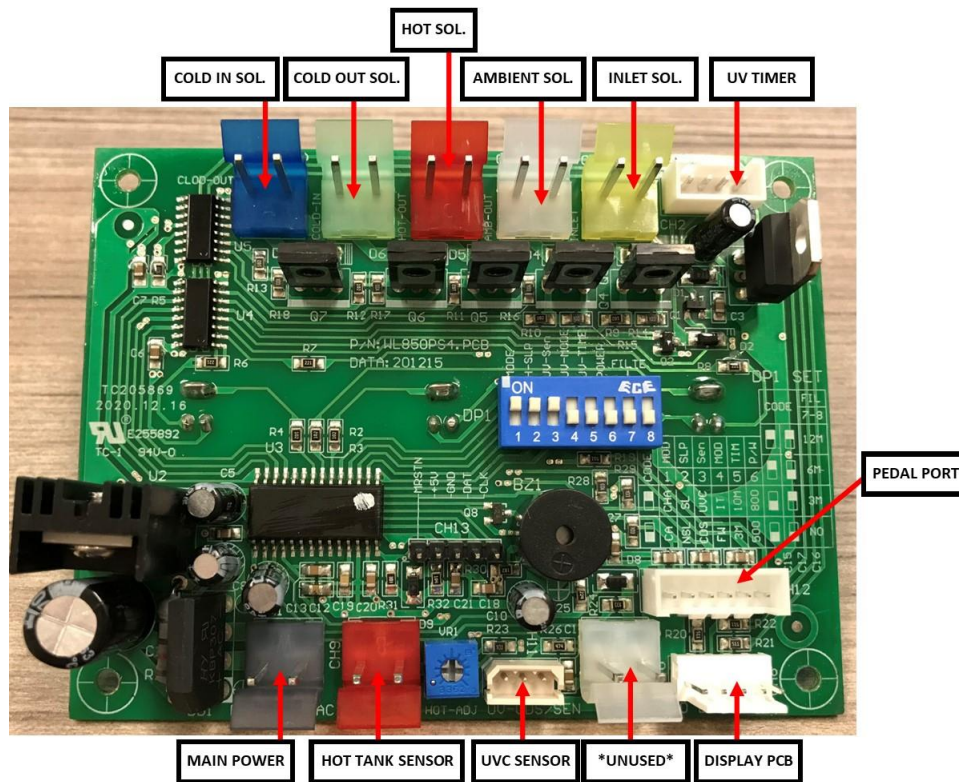

## WL3 FX ELECTRICAL DIAGRAM - SUPPLEMENT



DIPSWITCH #	CONTROL	ON <input type="checkbox"/>	OFF <input type="checkbox"/>
1	TEMP MODE	COLD/HOT/AMB	COLD/AMB
2	SLEEP MODE (3hr DELAY)	ON	OFF
3	UV SENSOR	UVC (Firewall)	CDS (In-Tank)
4	UV MODE	In-Tank UV	Firewall UV
5	UV TIMER (If #4 set to In-Tank UV)	10 Minutes	3 Minutes
6	HOT TANK POWER	800W (UK)	500W (USA)
7,8 (combo)	FILTER TIMER	12 Months <input type="checkbox"/>	6 Months <input type="checkbox"/> 3 Months <input type="checkbox"/> OFF <input type="checkbox"/>



## PRE-INSTALLATION PROCEDURES

-  **DANGER! ELECTRICAL SHOCK HAZARD.**  
*Only qualified personnel who have read and understand this entire manual should attempt to install, or service this **WL3 FX Water Treatment System**, failure to do so could result in death or serious injury. DO NOT plug into an electrical supply until specifically instructed.*
-  **WARNING! ALWAYS SANITIZE BEFORE USE.**  
*Sanitize before use to eliminate any potential microbiological contaminants.*
-  **CAUTION! DRIP TRAY DRAIN.**  
*If you intend to provide a drip tray drain for your customer, be aware that you will be called multiple times per month to service and unclog the tubing leading away from the drip tray to drain. Users will clog the drain with paper clips, erasers, napkins, tea bags, gum, and various other intended items. Waterlogic recommends you establish a minimum of weekly visits to the machine for cleaning of the drip tray drain.*

### Materials Needed:

- Personal Protective Equipment. Rubber or Nitrile Safety Gloves and Protective Eyewear
  - Phillips Screwdriver
  - Temperature Gage
  - Water Pitcher or Container to collect water from the faucet
  - 5-gallon container or drain basin
  - Sanitizer - Household Bleach (5.25% Sodium Hypochlorite) or Citric Acid Based Cleaner
  - ¼" Plastic Tubing, at least 4 feet in length, and assorted ¼" quick connect fittings
  - TDS Meter and Test Strips for measuring chlorine - Optional
1. Unpack the **Waterlogic WL3 FX Water Treatment System** and check exterior for damage.

### Flush Filters

-  **CAUTION! FILTER FLUSH REQUIRED.**

*WL3 FX's Water Treatment Systems are not supplied with filters. Filters should be configured to optimize your system. Filters need to be configured and specified to do the job given the local water conditions, usage, maintenance schedule, and placement restrictions.*

*In order for our filters to perform as represented and to provide the best quality water possible, it is essential that filters be replaced periodically. The frequency of filter changes depends upon your water quality and your water usage. For example, if there is a lot of sediment and/or particles in your water, then you will have to change your filters more frequently than a location with little to no sediment. Be sure to replace your filters whenever*

*you notice a decline in the performance, whether it is a drop in flow rate and/or pressure or an unusual taste in the water.*

2. Flush thoroughly per filter manufacturers' recommendation with fresh water to drain.
3. Once flushed, install the filters. Following the flow direction on the filter.

**NOTE:** Filters should not be flushed prior to 24 hours before installation to limit Microbial Growth.

### Sanitizing

Sanitize using a Household Bleach (5.25% Sodium Hypochlorite solution) or other approved cleaner throughout the cold and sparkling water circuits. Follow all instructions on the sanitizer and flush with fresh water through the faucet until odor and taste is acceptable.

**⚠️ WARNING! USE PROPER PERSONAL PROTECTIVE EQUIPMENT**

*Always ensure proper ventilation and use proper personal protective equipment such as gloves and eye protection when using chemicals. Refer to Material Safety Data Sheet for specific requirements of each chemical product. Take all necessary precautions to prevent sanitizer from contacting eyes, clothing, and any other surfaces in could damage (carpets).*

4. Mix ½ gallon of sanitizer per directions or use Bleach Solution (1 teaspoon = 1/6 oz. = 5 ml = ½ cap full) of household bleach (Sodium Hypochlorite 5 - 10% Concentration) with 1/2 gallon of water inside Sanitizing Cartridge. Always ensure sanitizer is compatible with stainless steel and acetyl plastic.
5. Connect sanitizing cartridge to inlet water supply and connect to inlet bulkhead fitting on back of unit. Turn on water supply.
6. Connect power to WL350 Water Treatment System and turn on Red Power Switch. DO NOT TURN ON GREEN COMPRESSOR & HEATER SWITCH AT THIS TIME. O=OFF
7. Turn on water supply and check for leaks.

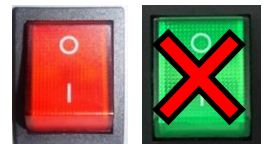

**⚠️ DANGER! ELECTRICAL SHOCK HAZARD.**

*Do not plug in unit unless qualified. Only qualified personnel who have read and understand this entire manual should attempt to install or service this unit.*

**⚠️ CAUTION! NEVER TURN ON HEATER BEFORE FILLING HOT TANK.**

### Fill the Cold Circuit with Sanitizer

8. Touch and hold the cold dispensing icon on the front control panel until cold water/sanitizing solution comes out the faucet. Stop dispensing and allow sanitizer to sit in cold tank for 10-15 minutes.

**NOTE:** Container and drain basin will be required to catch the water from the faucet.

**⚠ WARNING!** *Use Personal Protective Equipment. Gloves and Eye Protection Required. The first 2 or 3 gallons of water will contain concentrated sanitizer. Use extreme care!*

### Flushing the Sanitizer from the Machine

9. Place a pitcher, catch basin, or other container under the faucet of the **WL3 FX Water Treatment System**.
10. Flush the Cold Tank. Run several gallons of water through the faucet by dispensing cold water to dilute and remove the sanitizer from the cold circuit. You can use chlorine test strips to evaluate the water.
11. Once the sanitizer odor/taste has been flushed out of the cold side of the machine the sanitization process for the Cold Circuit is complete.

### Fill the Hot Tank

12. Tap, then press and hold the Hot Water icon, to fill the hot tank. Water will dispense from the faucet once the hot tank is full. Flush until water is clear.

**⚠ WARNING! HOT CIRCUIT IS NOT SANITIZED.**  
*Water in the hot circuit is not sanitary until the temperature exceeds 77°C (171°F) for at least 5 minutes.*

### UV System Functional Test

**⚠ WARNING! ULTRAVIOLET RADIATION.** *Protect your skin and eyes against ultraviolet rays. Never look directly at an operating UV light. Disconnect wiring before removing.*

13. Reinstall the UV Lamp and connect the wiring.
14. Dim or shield the overhead lights and peer into the machine, on top of the Cold Tank, at the UV connector and retaining cap. The blue glow indicates that the lamp is lit.

## Compressor Test

15. Switch Green Compressor / Heater to *I=ON position*. **Always ensure tanks are full of water before turning on the heater** or the overload (high limit) will open and require manual reset. If the wire condenser at back of the **WL3 FX Water Treatment System** is warm, the refrigeration system is working.



16. Once the machine reaches its target temperature, the compressor will shut off. Draw a glass of cold water and verify it has been chilled to proper temperature.

## Heater Test

17. **Always ensure tanks are full of water before turning on the heater** or the overload (high limit) will open and require manual reset. It will take the heater approximately 10 minutes to heat the water from ambient 24°C (75°F) to the factory set point of 85°C (185°F). Dispense a cup of hot water to ensure the temperature/odor/taste is acceptable.

**⚠ WARNING! HOT WATER.** *Unit produces Hot Water up to 87°C (188°F). Water above 52°C (125°F) can cause severe burns or scalding. Hot water should be dispensed carefully into insulated container to avoid injury.*

## WL3 FX COUNTER TOP DRAINING INSTRUCTIONS

### Draining Notes

Drain the **WL3 FX Water Treatment System** for transportation.

**⚠ WARNING! STORE UNIT EMPTY. ALWAYS SANITIZE BEFORE REUSE.**

*The unit must be completely drained and sealed before storing to avoid stagnation and reduce microbial growth).*

Prior to draining the hot tank, turn off the Green Heater and Compressor Power Switch (O=OFF), and dispense 2 liters of hot water from the machine. As hot water is dispensed from the faucet of the **WL3 FX Water Treatment System**, colder water will be introduced into the hot tank. Since the Green Heater and Compressor Power Switch is turned off, the heater will not energize and heat the incoming tap water. Following this precaution prevents exposing personnel and equipment (drains, catch basin, etc.) to scalding hot water.



### Disable Cold and Hot Tanks

1. Turn off the Green Heater and Compressor Power Switch (O=OFF) to disable the heater and compressor.
2. Dispense 2 liters (1/2 Gallon) of water through the hot tank to cool the water temperature in the hot tank and avoid burns.



**⚠ WARNING! HOT WATER.** *The WL3 FX Water Treatment System produces Hot Water up to 87°C (188°F). Water above 52°C (125°F) can cause severe burns or scalding. Hot water should be dispensed carefully into insulated container to avoid injury.*

### Turn off Water Supply and Bleed Water Pressure

3. Isolate the **WL3 FX Water Treatment System** from feed water by turning off the supply.
4. Dispense cold still water to relieve any pressure built up in the system.
5. Remove the top lid and front panel of the unit to reveal the drain ports at the bottom of the machine. **It is recommended to move the machine over a sink or place a container under the valves to catch drain water.**
6. Unscrew the cap of the Cold Drain port and Press and Hold the Cold Water Dispense Button until all Cold Water has drained from the **WL3 FX Water Treatment System out of the inlet port.** Replace cap when finished.
7. Repeat this procedure for the Hot Tank by using the Hot Valve and double pressing and holding the Hot Dispense button until all hot water has drained from the **WL3 FX Water Treatment Machine.** Replace the cap when finished.

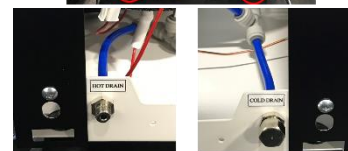
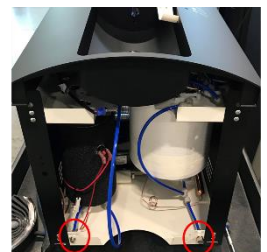

## WL3 FX TOWER DRAINING INSTRUCTIONS

### Draining Notes

Drain the *WL3 FX Water Treatment System* for transportation.

**⚠️ WARNING! STORE UNIT EMPTY. ALWAYS SANITIZE BEFORE REUSE.**

*The unit must be completely drained and sealed before storing to avoid stagnation and reduce microbial growth).*

Prior to draining the Hot Tank, turn off the Green Heater and Compressor Power Switch (*O=OFF*), and dispense 2 liters of hot water from the machine. As hot water is dispensed from the faucet of the *WL3 FX Water Treatment System*, colder water will be introduced into the hot tank. Since the Red Heater and Compressor Power Switch is turned off, the heater will not energize and heat the incoming tap water. Following this precaution prevents exposing personnel and equipment (drains, catch basin, etc.) to scalding hot water.



### Disable Cold and Hot Tanks

1. Turn off the Green Heater and Compressor Power Switch (*O=OFF*) to disable the heater and compressor.
2. Dispense 2 liters of water through the Hot Tank to cool the water temperature in the hot tank and avoid burns.



**⚠️ WARNING! HOT WATER.** *The WL3 FX Water Treatment System produces Hot Water up to 87°C (188°F). Water above 52°C (125°F) can cause severe burns or scalding. Hot water should be dispensed carefully into insulated container to avoid injury.*

### Turn off Water Supply and Bleed Water Pressure

3. Disconnect the *WL3 FX Water Treatment System* from feed water.
4. Dispense cold still water to relieve any pressure built up in the system.
5. Insert approx. 3 inches of blue tubing into the Line Bulkhead fitting at back of the *WL3 FX Water Treatment System* to allow water to drain out the inlet port.
6. Press and hold the Cold Water Dispense Button until all Cold Water has drained from the *WL3 FX Water Treatment System* through the inlet port.
7. Double press and hold the Hot Water Dispense Button until all Hot Water has drained from the *WL3 FX Water Treatment System* out of the inlet port. The machine is now drained.

**Bulkhead Fitting** 





## **INSTALLATION PROCEDURES**

### **Safety and Installation Guidelines**

Ensure all Local, State, and Federal Laws and Codes including health and safety guidelines are met when installing **Waterlogic** Equipment. Only qualified service technicians should attempt installation and service of **Waterlogic** Equipment.

- ⚠ WARNING! ELECTRICAL SHOCK HAZARD.** Always unplug (isolate from power supply) to prevent electrical shock except where electrical tests are specified.
- ⚠ WARNING! IMPROPER SUPPLY OR CONNECTION CAN RESULT IS RISK OF SHOCK.** Connect to a 15 amp, 120V 60Hz properly grounded outlet (GFI is recommended). Ensure polarity is correct and always use a 3-prong outlet. Consult a qualified electrician if you have any questions.
- ⚠ WARNING! USE ONLY Waterlogic SUPPLIED POWER CORD.** Locate system within 5 feet of power supply. Never use an extension cord or adapter. Do not use a damaged power cord or plug. Keep power cord out of heavy traffic areas and away from heat sources. Do not, under any circumstances, remove ground prong or alter the power cord. Never pull the power plug from the outlet with a wet hand or allow the plug to get wet. Failure to use the supplied power cord will void UL Certification and Warranty.
- ⚠ CAUTION! INDOOR USE ONLY.** Never expose to direct sunlight, heat sources, or ambient air temperature above 38°C (100°F) or below 2°C (35°F). Install indoors and keep unit away from excessive humidity. Never expose to freezing temperatures. Ensure there is adequate clearance around the unit to allow refrigeration system condenser to dissipate heat. Warmer environments require more clearance around the unit. Minimum clearance around all surfaces of the machine is 2-inches. Installs where the ambient temperature exceeds 80°F, require a minimum of 4-inches clearance for proper heat dissipation and efficient operation.
- ⚠ CAUTION! USE A WATER PRESSURE REGULATOR.** **Waterlogic** will not be responsible for injury or damage caused by excessive water pressure. Operating pressure must be 40 psi to 60 psi. Be aware any of potential pressure surges caused by building/municipal pumping stations.
- ⚠ CAUTION! USE UV STABILIZED SUPPLY LINES.** Feed the unit with a potable ambient or cold-water supply only. Feed water over 100° F (37°C) can damage the treatment components. Water block devices and external leak detectors are strongly recommended. Locate the unit as close to the water supply and the electrical connections as possible.
- ⚠ WARNING! STORE AND TRANSPORT UNIT EMPTY. ALWAYS SANITIZE BEFORE USE.** The unit must be completely drained and sealed before storing to avoid stagnation and reduce microbiological contamination (potential bacterial growth). Sanitize before use to eliminate any potential microbiological contaminates



Pre-installation and sanitization procedures as prescribed in this manual must be performed before installing the **WL3 FX Water Treatment System**.

Always install indoors and place the **Waterlogic WL3 FX Water Treatment System** on a firm, flat and stable surface.

1. Attach the water supply line to the 1/4" feed water inlet bulkhead fitting on the back of the **WL3 FX Water Treatment System**. **Waterlogic** requires the use of a water pressure regulator. Water feed pressure must be between 40-60 psi. Turn on the water supply and check for leaks.

2. Check to ensure that the Green Heater and Compressor Switch is the O=OFF position, and that the Red Power Switch is in the I=ON position

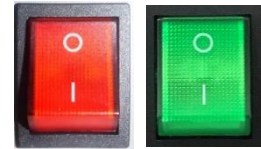

**NOTE:** Switches have internal LED that illuminates when placed in I=ON position.

3. Connect the power cord to the back of the **Waterlogic WL3 FX Water Treatment System** and to a 120 Volt supply.
4. Fill the Cold Tank. Hold a container under the dispensing faucet, press and hold the cold dispensing button until a continuous flow of water is obtained. Once a continuous flow is obtained, release the dispensing button. Cold tank is now full.
5. Fill the Hot Tank. Hold a container under the dispensing faucet. Double press and hold the Hot Dispense Button until a continuous flow of water is obtained. Once a continuous flow is obtained, release the Hot Dispense Button. Hot tank is now full.

**⚠ CAUTION! NEVER TURN ON HEATER BEFORE FILLING HOT TANK.**

*Green Heater and Compressor Switch must be in the O=OFF position while the Hot Tank is empty. Damage could occur within one minute and the overload (high limit) will require manual reset if heater is turned on with an empty Hot Tank.*



6. Verify that the UV Lamp operates as expected.

**⚠ WARNING! ULTRAVIOLET RADIATION.** *Protect your skin and eyes against ultraviolet rays. Never look directly at an operating UV light. Always disconnect before removal.*

7. Move the **Waterlogic WL3 FX Water Treatment System** into its final operating position. Be sure that a minimum of 2" clearance is maintained around both sides and the back of the **WL3 FX Water Treatment System**.
8. This is important to allow proper airflow and heat exchange of refrigeration system.
9. Level the **WL3 FX Water Treatment System** using the adjustable feet to level if necessary. Never install on incline.
10. Turn the Green Heater and Compressor Switch to I=ON position.

11. When the **WL3 FX Water Treatment System** has reached its Hot Temp Set Point, the heater will cycle off. When the **WL3 FX Water Treatment System** has reached its Cold Temp Set Point Temperature, the compressor will cycle off.
12. Once the **WL3 FX Water Treatment System** is at the target temperature(s), sample the water to ensure water meets expectations and additional rinsing or adjustment is not required.
13. Check the **WL3 FX Water Treatment System** for any leaks. External Leak Protection is always recommended.



## FAULT CODE TROUBLESHOOTING INDEX

**Note About Energy Saver:** In order to qualify for Energy Star, this unit comes with the energy saver defaulted to ON. If no buttons are pressed on the front panel for 3 hours, the WL3 FX will enter sleep mode, and power to the heater will be shut down. The cold water (compressor) will remain active/on 24/7.

To exit sleep mode, one of the front panel buttons (Cold Dispense, Hot Select or Room Select) must be pushed. To disable Energy Saver Mode, see Page 59.

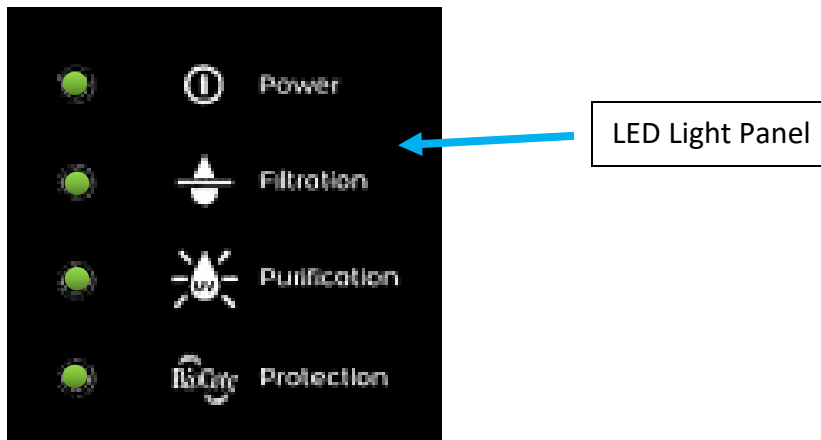

LED	Color	Remarks
Power	Green	<ul style="list-style-type: none"> <li>Always lit (while machine is on)</li> <li>Will turn off in Sleep Mode</li> </ul>
Filtration	Green	<ul style="list-style-type: none"> <li>Always lit</li> <li>Will turn off in Sleep Mode</li> <li>Will be off if Filter Timer set to "NONE"</li> <li>Will flash continuously if Filter Timer reaches 0:00. See page 61 for filter timer reset.</li> </ul>
UV	Green	<ul style="list-style-type: none"> <li>Stays lit under normal operation</li> <li>If UV error, will flash continuously with audible alarm and machine will not dispense Cold or Ambient water.</li> </ul>
BioCote	Green	<ul style="list-style-type: none"> <li>Always lit</li> <li>Will turn off in Sleep Mode</li> </ul>

## DISABLING ENERGY SAVING MODE

**NOTE: THIS CHANGE MUST BE MADE WITH THE MACHINE OFF AND UNPLUGGED. IF NOT DONE, THE CHANGE WILL NOT BE RECOGNIZED.**

Note the DIP switches on the main PCB (the one mounted to the back side of the front upper panel):

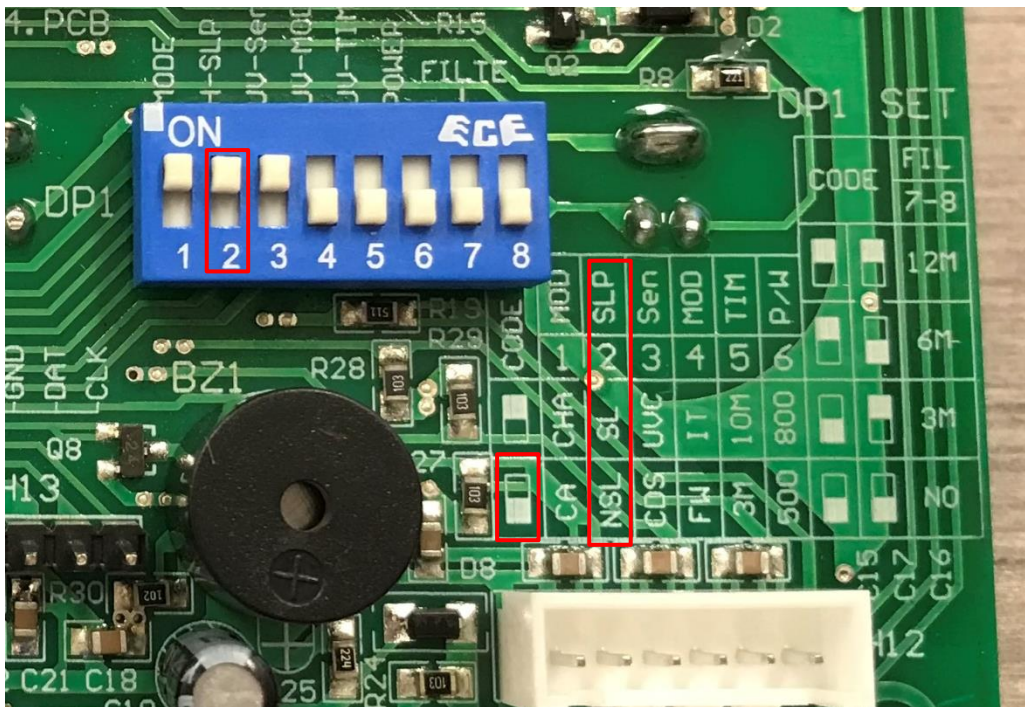

To **DISABLE** the energy saver, DIP #2 must be switched from ON to OFF (Down position), as per the legend printed on the board. This will enable the hot tank to cycle continuously. All units come with Sleep Mode enabled.

## RESETTING THE FILTER TIMER

If the **WL3 FX Water Treatment System** has the Filter Timer dipswitches set to 3, 6, or 12 months, and the selected period has passed, the Filtration LED will begin blinking. This warning indicates that the filters need to be changed, and will continue until the timer has been reset, OR the Filter Timer has been set to “NONE.”

To reset the filter timer, simply depress **AND HOLD** both the Cold **AND** Hot dispense buttons simultaneously for 15 seconds. A brief audible alarm will sound, indicating the timer has been reset. Release the buttons once it sounds.

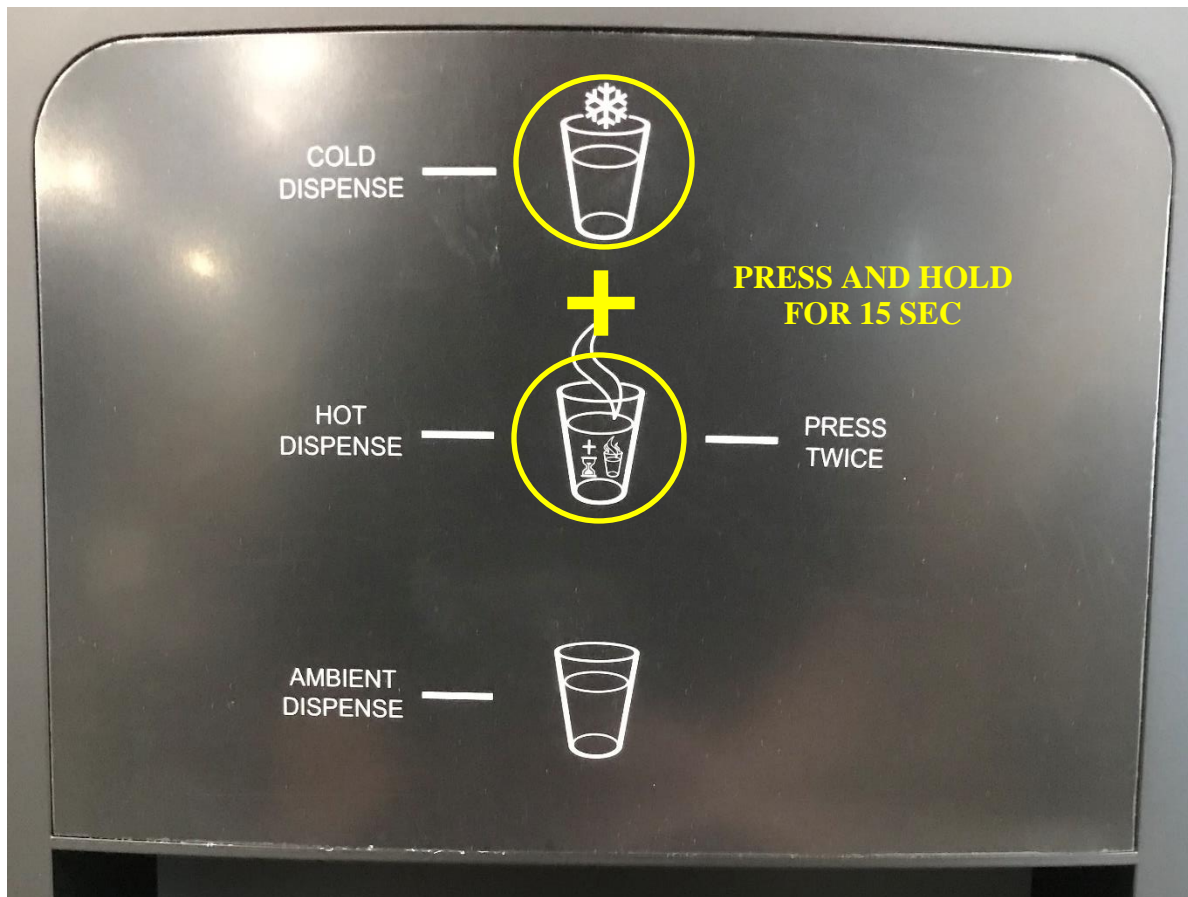



## **HOT TANK OVERHEAT (ROR PROTOCOL TRIGGERED)**

The **WL3 FX Water Treatment System** has an ROR (Rate of Rise) protocol in the programming that will disable the hot tank and give audible and visual alarms if the temperature in the Hot Tank rises too rapidly, which usually indicates dry heating. The Hot Tank **MUST HAVE WATER IN IT** before the Green heater/compressor switch is turned on. Heating without water can damage the tank and the machine.

If this occurs, disconnect the machine from power for 10 seconds to allow the alarm to reset. Turn OFF the Green switch. Reconnect to power, with the Red Power switch ON and the Green switch OFF. Dispense water from the hot tank as normal. Once water flows, turn the Green switch back ON. If there is no water flowing from the hot tank, investigate further for other potential failures.

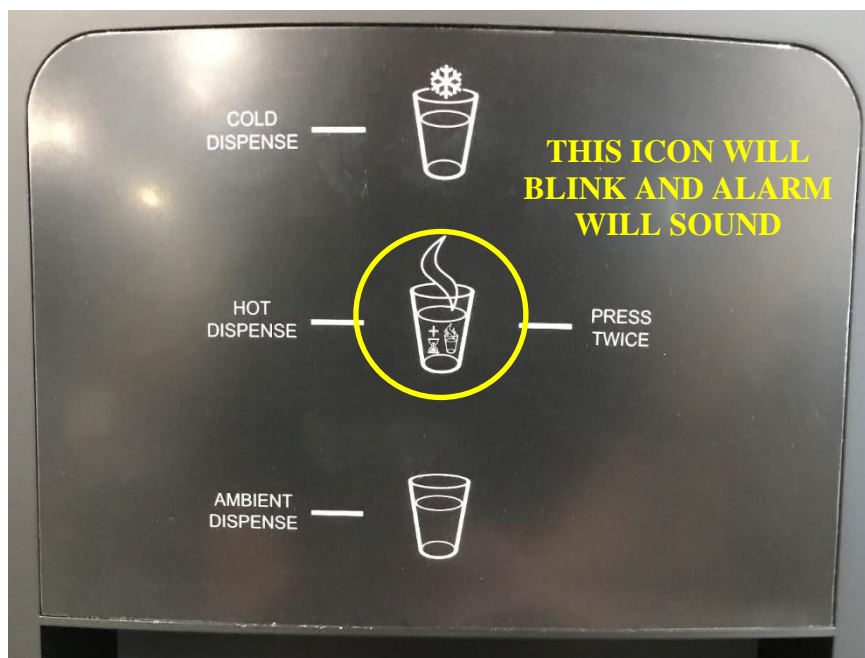

## RESETTING THE HOT TANK OVERLOAD

The **WL3 FX Water Treatment System** has a Hot Tank equipped with a High Limit or Overload Thermostat. This is to prevent damage to the unit if the temperature in the Hot Tank gets too high. If the temp does get out of control, this Overload Thermostat will break the electric connection, cutting power from the heating element. The Overload Thermostat will have to be manually reset to continue normal operation of the Hot Tank. The photos below outline how to access and reset the mechanism.

**⚠ Unplug the machine from power.** Remove the two screws at the back of the top lid and remove.

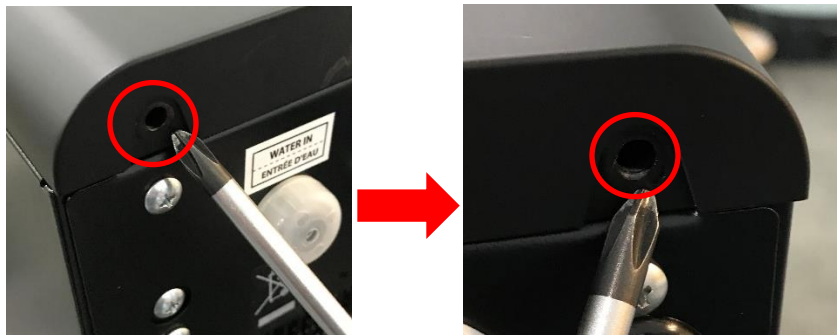

With cover removed, locate and remove the two screws on the backside of the front panel. Then locate and remove the three screws holding the Firewall in place. **Tower models will require the lower front panel be removed as well before continuing.**

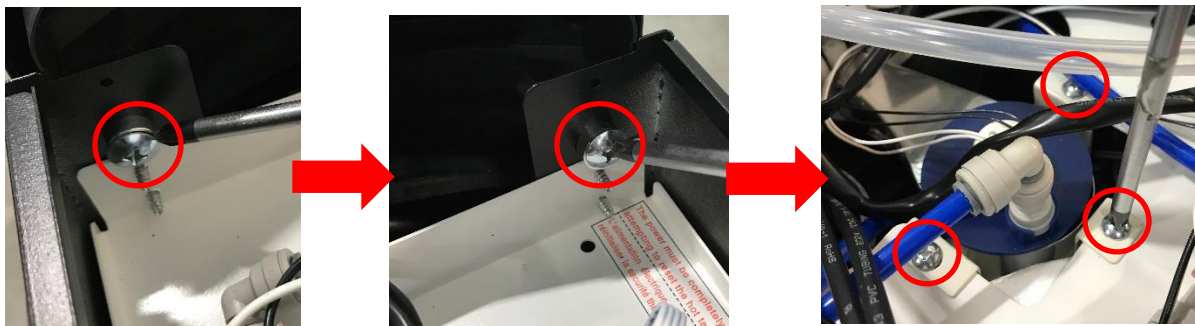



Lift the Firewall assembly off the white shelf and pull the front panel away from the machine. Without disconnecting any wiring, slightly pull the panel away from the front of the machine, enough to give room to fit your hand inside the front of the machine. Locate the Overload Thermostat on the front of the Hot Tank (has a bright red button on it). Reach in and depress the red button in the center of the thermostat to manually reset the Overload Thermostat.

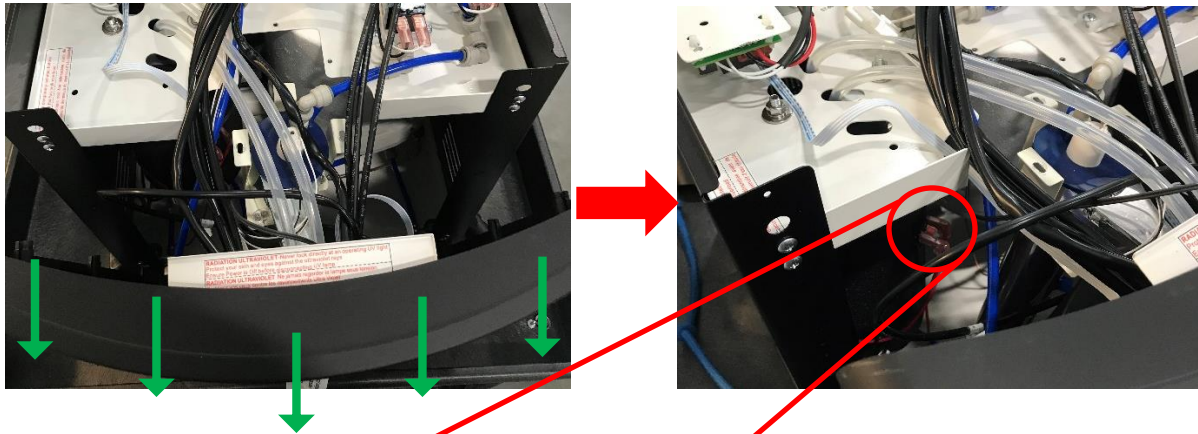

← **CLOSE UP OF THE MANUAL OVERLOAD**

## POWER TROUBLESHOOTING INDEX

1. Red Heater and Compressor Power Switch won't light
2. Red Power Switch is lit but No Hot and Cold Water
3. Compressor Runs but does Not Chill
4. Compressor is Not Running
5. Red Power Switch is lit, but Green Power LED is not lit

### **1. Red Heater and Compressor Power Switch won't light and the Red LED on the Front won't light**

Possible Reason	Solution
Circuit Breaker	Check the Circuit Breaker
Fuse is Blown	Replace Fuse
Defective / Loose Power Cord	Check that power cord is properly plugged in. If it is properly plugged in, use a different power cord to verify.
Failed Power Line Noise Filter, Electro Magnetic Interference filter (EMI)	Replace Power Line Noise Filter, Electro Magnetic Interference filter (EMI)
Defective Red Heater / Compressor Switch	Replace Red Heater / Compressor Switch



### **2. Red Power Switch is lit but There is No Hot or Cold Water**

Possible Reason	Solution
Bad Transformer	Replace Transformer
Black Power Connector to the PCB is not properly connected	Properly connect.
Bad Front PCB	Replace Front PCB - P/N EN-0135-L00-00
Defective Red Power Switch	Replace Red Power Switch

### 3. Compressor Runs but Does Not Chill

Possible Reason	Solution
Condenser is dirty	Clean the condensing coil of any obstructions or dust.
Reduction of airflow into unit.	Make sure unit is not under minimum ventilation requirements (2 to 4 inches).
Compressor is running very hot.	Low or lost refrigerant. Refrigerant recharge required.

### 4. Compressor is Not Running

Possible Reason	Solution	
Green Heater and Compressor Switch button on unit is in the off position	Turn Green Heater and Compressor Switch on. <i>I = ON</i>	
Compressor Starting Circuit	<p>Turn Green Heater and Compressor Switch off. <i>O = OFF</i>.</p> <p>Remove the compressor cap on side of the compressor;</p> <p>Disconnect the black and red terminal connectors;</p> <p>Inspect the starter and overload relay for any defects.</p> <p>Replace component(s) as needed.</p> <p>Turn Red Heater and Compressor Switch on <i>I = ON</i> and retest compressor operation.</p>	

### 5. Red Power Switch is lit, but Green Power LED is not lit

Possible Reason	Solution
Machine is in Sleep Mode	Press any Dispense Button to wake the machine. Power LED should become lit and Hot Tank will begin heating again.

## **DISPENSING TROUBLESHOOTING INDEX**

1. Dispensing won't stop when not holding the Dispensing Button
2. Water does not dispense from unit
3. Steady Drip out of Faucet
4. Irregular / Intermittent Dispensing
5. Small amount of water periodically dispenses from faucet automatically
6. Low Flow of Water – Rated Service Flow is 1.89 Liters (0.5 gallons) per Minute
7. Hot Water Intermittently Forced Through the Faucet, or a Dual Stream Out of the Faucet
8. Hot Water coming out of both the Faucet and the Vent Hole
9. Hot Water Drip out of Faucet
10. Dispenses Hot and Cold Water at the same time
11. No Cold Water Available
12. No Ambient Water Available
13. Cold Water dispenses from Faucet and Vent Outlet Simultaneously
14. Dispense Buttons stick
15. Run-On Water continues to dispense out of faucet after releasing the dispense button

*Also includes related instruction for Hot Tank Descaling*

## 1. Dispensing Won't Stop when Not Holding the Dispensing Button

Possible Reason	Solution
Too much water pressure. Recommend 40-60 psi for the <b>WL3 FX Water Treatment System</b> to operate properly.	The correct input water pressure is critical to the performance of the unit to allow solenoids to open.  Check water pressure at the inlet bulkhead with a water pressure gauge. Additional method of verification is to turn off water to unit and press the dispense button. Does the solenoid open without water pressure to the unit? Listen for solenoid to activate, not button "click".  Adjust water pressure to 40-60 psi.
Bad Display PCB	Replace Front PCB Hot and Cold – P/N EN-6085 WLCP PN 12-8103 Cold Only – P/N EN-6086 WLCP PN 12-8615
Debris in the Solenoid	Inspect Solenoid for debris and clean out as needed.
Dispensing Button Stuck	Dirt or Foreign material is filling the gap around the push-buttons. Inspect the push buttons and clean surrounding area. Inspect faucet assembly inside the unit and clean as necessary.

## 2. Water does not dispense from Unit

Possible Reason	Solution
Too much water pressure. Recommend 40-60 psi for the <b>WL3 FX Water Treatment System</b> to operate properly.	The correct input water pressure is critical to the performance of the unit to allow solenoids to open.  Check water pressure at the inlet bulkhead with a water pressure gauge. Additional method of verification is to turn off water to unit and press the dispense button. Does the solenoid open without water pressure to the unit? Listen for solenoid to activate, not button "click".  Adjust water pressure to 40-60 psi.
Closed water supply valve	Open the water supply valve.
The unit is not properly plugged into electrical outlet	Check electrical outlet connection, or for blown circuit breaker.
Green Heater and Compressor Switch on unit is in the off position	Turn Green Heater and Compressor switch on. <i>I = ON</i>
15 Amp Fuse Blown	Replace the 15 Amp Fuse as needed.



Hot and Cold Solenoid connections into the Display PCB are loose.	Turn power off; unplug the unit and visually inspect solenoid connections into the Display PCB. Verify the soldering points on connections are secure into the board. Remove the PCB to inspect the front of the board.
Exhausted Filter	Replace filters as needed.

### 3. Steady Drip Out of Faucet

Possible Reason	Solution
Debris in Solenoid	Inspect Solenoid for debris and clean out as needed.

### 4. Irregular / Intermittent Dispensing

Possible Reason	Solution
Too much water pressure. Recommend 40 to 60 psi for <b>WL3 FX Water Treatment System</b> to operate properly.	<p>Check water pressure at the inlet bulkhead with a water pressure gauge.</p> <p>Additional method of verification is to turn off water to unit and press the dispense button. Does the solenoid open without water pressure to the unit? Listen for solenoid to activate, not button “click”.</p> <p>Adjust water pressure to 40-60 psi.</p>
Loose or bad connection on the Front Dispensing PCB or Solenoid Connector	Check that they are connected properly and tightened.
Solenoid	If both the Water Pressure and PCB have been ruled out, then it is the Solenoid. Replace Solenoid.
Dispensing button is broken on PCB	Check PCB for loose or damaged button. Replace PCB as necessary.

### 5. Small Amount of Water Periodically Dispenses from Faucet Automatically

Possible Reason	Solution
Cold or Hot Water Solenoid Valve malfunction`	Inspect valve components for proper function. Replace as necessary.
Obstruction in Solenoid housing is preventing proper sealing of component	<p>Pre-determine whether water being dispensed is Hot / Cold.</p> <p>Isolate the water supply; push the DISPENSE button to release the line pressure, and remove the coil affixed to the Solenoid stem.</p> <p>Remove the stem from the solenoid housing and allow water from the tank to flush out the contaminate(s).</p>

## 6. Low Flow of Water – Rated Service Flow: 1.9 L/min (0.5 gal/min)

Possible Reason	Solution
Determine Flow of Water	Rated Flow Rate is 1.89 Liters (0.5 gallons) per Minute. Check Flow Rate by dispensing into a container for one minute. Measure the amount of water that has been dispensed.
Feed Lines too small	Feed lines can restrict flow if run long distances from the supply. It may be necessary to increase the supply line (e.g. use 3/8" feed line versus 1/4").
Elbows and turns in the line	Minimize elbows and turns in the feed line.
Filters	Filters with high pressure drop due to fouling or just by design. Change filters more frequently or go to higher micron size filter for local water conditions.
Restrictions	Flow path to ensure there are no undiscovered restrictions due to debris or malfunctioning valves, including the supply valve at the source.
Booster Pump	Add a booster pump to the supply line if the feed is slower than needed.

## 7. Hot Water Intermittently Forced Out through the Faucet, or a Dual Stream out of the Faucet

Possible Reason	Solution
Mineral deposits on the expansion slot inside the Hot Tank vent chamber which blocks the normal path of water to expand.	Descale the Tank. <u>See Hot Tank Descaling Instructions that are included further below in this Troubleshoot Section.</u>



## 8. Hot Water Coming out of Faucet Vent Hole

Possible Reason	Solution
<p>Too much water pressure. Recommend 40 to 60 psi for <b>WL3 FX Water Treatment System</b> to operate properly.</p>	<p>Check water pressure at the inlet bulkhead with a water pressure gauge.            Additional method of verification is to turn off water to unit and press the dispense button. Does the solenoid open without water pressure to the unit? Listen for solenoid to activate, not button "click".            Adjust water pressure to 40-60 psi.</p>
<p>Improper tubing attachment from the tank to faucet or vice versa.</p>	<p>Verify tubing is connected properly from tank outlets to correct faucet attachments.</p>
<p>Hot Tank outlet hole is scaled over.</p>	<p>Inspect and Descale Tank as needed.  <u><b>See Hot Tank Descaling Instructions that are included further below in this Troubleshooting Section.</b></u>            See instructional video on the Partner Area of the Waterlogic.com website for more information.</p>
<p>Expansion chamber is not sealed properly.</p>	<p>Replace the Hot Tank.</p>

## 9. Hot Water Drip out of Faucet

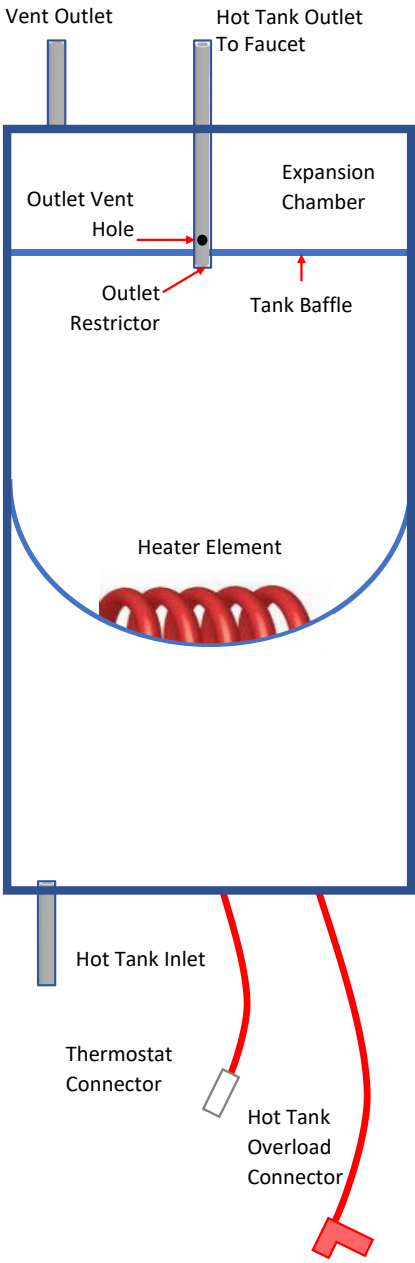
Possible Reason	Solution
<p>Small Outlet Vent Hole susceptible to scale build up.</p>	<p>Descalc Tank.  <u>See Hot Tank Descaling Instructions that are included further below in this Troubleshooting Section.</u>            See instructional video on the Partner Area of the Waterlogic.com website for more information.</p>
	<p>All <b>Waterlogic</b> Hot Tanks have a built in Vent or Expansion Chamber in the top of the tank except for WL270 (GF) units.</p> <p>The Vent Chamber allows for expansion of the water when it is heated.</p> <p>The chambers are separated by a welded-in tank baffle.</p> <p>Water always flows into the bottom of the tank and out the top to the faucet.</p> <p>The hot tank outlet tube has a restrictor in its base. This ensures the reservoir is always full by allowing more water in than out.</p> <p>There is a small hole in the side of the tank outlet tube that allows air and water to pass into the vent chamber as it is heated.</p> <p>Water in the vent chamber is suctioned back through the outlet tube vent hole when water is dispensed.</p> <p>Expansion of water as it is heated in the reservoir will push the water out the faucet when the outlet tube vent hole becomes plugged with debris or scale.</p> <p>The small Outlet Vent Hole is susceptible to scale build up and is a key indicator that descaling is required.</p> <p>It is critical to descale the hot tank through the vent line and outlet line on a regular basis to prevent this problem.</p> <p>Descaling through the inlet and/or outlet lines only will not clean the vent chamber and outlet vent hole properly.</p>

## 10. Dispenses Hot and Cold Water at the Same Time

Possible Reason	Solution
Too much water pressure. Recommend 40 to 60 psi for <b>WL3 FX Water Treatment System</b> to operate properly.	Check water pressure at the inlet bulkhead with a water pressure gauge. Additional method of verification is to turn off water to unit and press the dispense button. Does the solenoid open without water pressure to the unit? Listen for solenoid to activate, not button “click”. Adjust water pressure to 40-60 psi.
Hot or Cold solenoid is stuck open.	Remove Top cover. Check Hot Solenoid: Dispense cold water and visually inspect tubing for water flow from both tanks. Check Cold Solenoid: Disconnect elbow from outlet of cold solenoid. Select hot water and dispense (quickly releasing dispensing button to avoid much water coming out of cold solenoid). Replace solenoid as necessary.

## 11. No Cold Water Available

Possible Reason	Solution
Too much water pressure. Recommend 40 to 60 psi for <b>WL3 FX Water Treatment System</b> to operate properly.	Check water pressure at the inlet bulkhead with a water pressure gauge. Additional method of verification is to turn off water to unit and press the dispense button. Does the solenoid open without water pressure to the unit? Listen for solenoid to activate, not button “click”. Adjust water pressure to 40-60 psi.
Closed Water Supply Valve	Open the Water Supply Valve
Cold Water Solenoid Valve malfunction	Inspect the valve components for proper functionality.
Green Heater and Compressor Switch on unit is off.	Turn Green Heater and Compressor Switch on. <i>I = ON</i>
Loose connection(s) on the Display PCB	Turn power off; unplug the unit and visually inspect solenoid connections into the Display PCB. Verify the soldering points on connections are secure into the board. Remove the PCB to inspect the front of the board.
Exhausted Filter	Replace filters as needed.



## 12. No Ambient Water Available

Possible Reason	Solution
Too much water pressure. Recommend 40 to 60 psi for <b>WL3 FX Water Treatment System</b> to operate properly.	<p>Check water pressure at the inlet bulkhead with a water pressure gauge.</p> <p>Additional method of verification is to turn off water to unit and press the dispense button. Does the solenoid open without water pressure to the unit? Listen for solenoid to activate, not button “click”.</p> <p>Adjust water pressure to 40-60 psi.</p>
Closed Water Supply Valve	Open the Water Supply Valve
Ambient Water Solenoid Valve malfunction	Inspect the valve components for proper functionality.
Loose connection(s) on the Display PCB	Turn power off; unplug the unit and visually inspect solenoid connections into the Display PCB. Verify the soldering points on connections are secure into the board. Remove the PCB to inspect the front of the board.
Exhausted Filter	Replace filters as needed.

## 13. Cold Water Dispenses from Faucet and Vent Outlet Simultaneously

Possible Reason	Solution
Improper tubing attachment from the tank to faucet or vice versa	Verify tubing is connected properly from tank outlets to correct faucet attachments.
Scale has formed inside cold tank outlet tube.	Remove cold water outlet tube from tank to faucet. Pour some scale remover into cold tank.
Expansion chamber in Cold Tank is not sealed properly.	Replace Cold Tank.

## 14. Dispense Buttons Stick

Possible Reason	Solution
Dirt or Foreign material is filling the gap around the push-buttons.	<p>Inspect the push buttons and clean surrounding area.</p> <p>Inspect faucet assembly inside the unit and clean as necessary.</p>

**15. Run On – Water continues to dispense out of faucet after releasing the dispense button**

**Reason**

“Run On” or “Carry On” is present in all Waterlogic pressure fed units without outlet solenoids.

“Run On” is defined as the amount of water that continues to dispense out of the faucet after releasing the dispense button.

Run On exists because the tanks pressurize as water is being dispensed. Every Waterlogic tank has an outlet restrictor to ensure the tanks remain full of water and water is controlled as it is released to the faucet. The inlet solenoid controls flow into the tanks. The tanks will “depressurize” once the dispense button is released the inlet solenoid closes. A small amount of water will “Run On” through the faucet as the tank depressurizes to atmospheric conditions.

Typical “Run On” is 2-3 seconds.

**“Run On” can be reduced by installing a pressure limiting device.**

The amount of inlet or supply pressure directly impacts the amount of “Run On” as quantified below.

WLCP Lab Testing of Rn On 7-31-2013				
Pressure	Pressure	Time	Flow Rate	Run On
Static PSI	Dynamic PSI	4 Liters	l/min	Seconds
68	40	61	2.9508197	3
50	30	72	2.5	2.5
32	20	92	1.956217	2
Pressure measured at inlet line to unit. Static with unit closed. Dynamic with unit dispensing cold water.				
No filters were installed in unit.				

## COLD WATER TROUBLESHOOTING INDEX

### 1. Cold Water is not Cold (41° +/- 5° F)

#### 1. Cold Water is not Cold (41° +/- 5° F)

Possible Reason	Solution
No power or refrigeration elements	<p>Check that the Green Heater and Compressor switch is on.</p> <p>Turn Green Heater and Compressor Switch on. <i>I = ON</i></p> 
<p>Tank has run out of cold water.</p> <p><i>Cold tank capacity is 4 liters for Tower and 2 liters for Counter Top.</i></p>	<p>Wait for cold tank to chill water to temperature prior to dispensing more cold water.</p> <p>A greater capacity of <b>Waterlogic</b> Water Systems is available.</p>
Cold Water Thermostat	Check continuity of thermostat with multimeter. Replace thermostat as required.
Refrigerant has run out	Run compressor for at least ten minutes. If condenser is not warm, then refill the refrigerant.
Compressor problem	If Compressor is not running, repair or replacement is needed.

## HOT WATER TROUBLESHOOTING INDEX

### Hot Water Problems

1. Hot Water is not Hot 85°C +/- 15°C (185°F +/- 5°F)
2. Hot Water Icon blinks and audible alarm sounds

*Also includes related instructions for Resetting the Hot Tank Overload or High Limit Safety*

#### 1. Hot Water is not Hot 85 +/- 15°C (185° +/- 5° F)

**NOTE:** The Hot temperature set point is 85°C +/- 15°C (185°F +/- 5° F) and is controlled by a thermostat on the side of the tank.

There is a resettable overload or high limit safety above the thermostat on the side of the tank that will trip to prevent damage to the unit if the tank is dry heated (turned on without water in it).

It typically takes 10 minutes for the 500W to heat the 1.5 Liter of room temperature (ambient) water to the 85°C (185°F) set point.

Possible Reason	Solution
No power to heater elements	Check that the Green Heater and Compressor switch is on.  Turn Green Heater and Compressor Switch on. <i>I = ON</i> 
Hot Tank Overload Tripped	Overload will “click” when pushed. The overload is automatically reset when pressed.
Thermostat or overload “open” on Hot Tank	Turn Power off. Check OHM’s resistance across terminals on each Thermostat and Overload separately. Good components will indicate a closed circuit or “0.00” OHM’s on the meter. Replace components as necessary.
Heating Coil Not Working	Turn Power off; Drain hot tank; Use multi-meter to check heater element for approximately 26 OHM’s resistance. Hot Tank must be empty if you are checking for continuity. Replace Hot Tank as necessary.
Loose or improperly connected wire(s) to the Heating Element / Hot Tank.	Visually inspect wire leads going to the hot tank; confirm proper connections to the heating elements. Hot tank life is 3-5 years, depending on usage.



## 2. Hot Water Icon blinks and audible alarm sounds

Possible Reason	Solution
Temperature has risen too fast in the hot tank and ROR protocols have been activated	Usual indication that hot tank is dry heating (no water in hot tank). Unplug machine from power to reset alarm. Reconnect to power and turn off the green switch to power down the compressor and heater. Attempt to dispense water from the hot tank. Once water flows, turn the green switch back on.
Hot Tank Overload Tripped	Overload will “click” when pushed. The overload is automatically reset when pressed.